

Self-Leveling Stow-Away Pool Table: Spring 2015 Final Report

ME Senior Design Team 6:

Travis Jarboe (tfj12), Joel Manahan (jcm11e),

Matthew McHugh (mrm10c), Thomas Silva (txs10)



Beyond Innovation, LLC

Sponsors: Mike Devine & Alexander York

Advisor: Dr. Chiang Shih

Instructor: Dr. Nikhil Gupta

Submitted: April 10, 2015

Table of Contents

Table of Figures	3
Table of Tables	5
ABSTRACT	6
ACKNOWLEDGMENTS	7
1. Introduction	8
2. Background Research	10
3. Concept Generation	13
4. Final Design	15
4.1 Marketability	15
4.2 Components/Subassemblies	16
4.2.1 Frame	16
4.2.2 Rail Subassembly	16
4.2.3 Leg Assembly	19
4.2.4 Dolly Assembly	20
4.2.5 Self-Leveling System.....	21
4.2.6 Wood Aesthetics	21
4.2.7 Full Assembly Exploded View	22
4.3 Operation.....	22
4.3.1 Stowing Procedure	22
4.3.2 Leveling Controls.....	25
4.4 Dimensions/ Tolerances	26
4.4.1 Leveling Tolerances.....	26
4.5 Finite Element Analysis	27

4.6	FMEA.....	30
5.	Design of Experiment	31
5.1	Electronic Component Testing.....	31
5.1.1	Orangutan X2, VNH2 Motor Drivers & Linear Actuators	31
5.2	Mechanical Component Testing.....	35
5.2.1	Frame Components	35
5.2.2	Leg Components	35
5.2.3	Feet, Carts and Locking Mechanisms	35
6.	Project Management.....	37
6.1	Schedule	37
6.2	Resources	37
6.3	Procurement	38
6.4	Communication	39
7.	Conclusion	41
	References.....	42
	Appendix A: Dimensioned Drawings	43
	Appendix B: Programming Flowchart	52
	Appendix C: FMEA.....	53
	Appendix D: Gantt Chart	54
	Appendix E: Bill of Materials	55
	Biography.....	56

Table of Figures

Figure 1. Group 19's original prototype [1]	11
Figure 2. David Hall's self-leveling boat platform	12
Figure 3. The Gyroscopic Pool Table located on Royal Caribbean's Radiance of the Sea.....	12
Figure 4. Design Concept #1	13
Figure 5. Design Concept #2	14
Figure 6. Design Concept #3	14
Figure 7. Final Design Concept (Entertainment System Housing).....	15
Figure 8. Frame composed of hollow steel tubing.....	16
Figure 9. Rail Assembly	17
Figure 10. End Bumper Removal (Top) and Side Bumper Removal (Bottom)	18
Figure 11. Leg Assembly	19
Figure 12. Leg Assembly Exploded View	19
Figure 13. Dolly Assembly	20
Figure 14. Dolly Assembly Exploded View	20
Figure 15. Final Design Exploded View.....	22
Figure 16. Dollies lined up with table.....	23
Figure 17. After pins are inserted into table and feet are retracted.....	23
Figure 18. Folding Leg Locking Mechanism	24
Figure 19. Table in stowed position, ready to move.....	24
Figure 20. Table after rotation into locking position	24
Figure 21. Angle Inclination along Longitudinal Axis.....	26
Figure 22. Angle Inclination along Latitudinal axis	26
Figure 23. Dolly FEA	29

Figure 24: Self-Leveling Testing Mechanism 33

Figure 25. Budget breakdown for the SLSA Pool Table 38

Table of Tables

Table 1. Budget breakdown for 2013 Sr. Design Team 19	10
Table 2. Team Average (Rounded) Stow-away Design Decision Matrix	13

ABSTRACT

The game of billiards has evolved over hundreds of years and is popular in today's society. Although many wish to own a pool table of their own, the tables are large, usually dedicating an entire room, extremely heavy, and require professional leveling any time they move; each of which make owning a pool table an inconvenience and an expense. With these topics in mind, it is our goal to design and manufacture a self-leveling stow-away pool table that maintains an elegant quality and meets tournament standards. It is with intent that our product will increase the availability of highly valued real-estate space, such as in bars, restaurants, and residential homes. Finding that there are no other pool tables in the market that are as user friendly, practical, and affordable, our stow-away self-leveling pool table could be considered an engineering and marketing accomplishment. From the project's start, the time and effort invested in ensuring the design concept was feasible and logical for a spectrum of consumers allowed for a smooth design process. The final design proved successful with the construction of the product and future business opportunity.

ACKNOWLEDGMENTS

Finances:

The financial provisions from Alexander York and the College of Engineering are greatly appreciated. The budget for the project this year will provide for a great end product.

Advice:

Dr. Shih has given great considerations about the overall project design and budget allocation.

Dr. Gupta was always very helpful towards the understanding of the electronics involved in the leveling system of the table. He has also provided great feedback on report formatting, presentations, and team organization.

Dr. Hollis has been helpful in structural considerations especially having to do with the rotational support of the pool table as well as other connections.

Alexander York was there to help us in all aspects of the project, as a sponsor and adviser. We are very thankful for the opportunity to handle a project of such high importance to him.

Stephen Avery's help was crucial to the development of this project. His time helping us was as generous as his expertise and aptitude for engineering matters.

Last, but certainly not least, a huge thank you to the engineering school's machine shop's Jeremy Phillips and James Gillman. The time they dedicated to this project was immeasurable. More importantly, we thank them for their patience and their commitment to improving our project every step of the way.

1. Introduction

Billiards is a game of both immense precision and accuracy, the player must calculate exactly where to hit each ball in order to get them to the desired position. This means that the geometry of the table must also be precise. Most importantly, the playing surface of the table must be almost perfectly level so that the direction of the balls movement is based purely on how they are struck. The problem with this arises when the ground of the pool table morphs over time or the pool table is moved to a new location and the playing surface of the table is no longer level. Because of this problem, a pool table is normally seen as a permanent fixture in a household or commercial setting. The average pool takes up 4 feet by 8 feet of ground area, this is a lot of space that could be otherwise be used for various reasons while the pool table is not in use. This brings the necessity for a pool table that can be easily moved without having the burden of being re-leveled with every move. The answer to this necessity is the development of a self-leveling stow-away pool table. In order for a pool table with both self-leveling and stow-away capabilities to be effective, it must be safe, quick and easy to use. The table must also be regulation size and have the same look and feel as a traditional, high-end pool table in order to maintain user satisfaction.

The Self-Leveling Stow-Away (SLSA) Pool Table designed by Team 6 required extensive background research into similar products already on the market and analysis of all possible design constraints. In order to satisfy all design constraints and create a unique product, strict design specifications for the table were set. These specifications are as follows:

- Stow away to reduce the foot print by at least 75%
- Self-level, with the press of a button, in under 5 minutes
- Capable of easily being stowed away by one person
- Maintain look and feel of a traditional pool table

Recognizing design constraints and setting design specifications allowed for the team to develop multiple design concepts and to consider. A final design concept was selected and it has been slowly tweaked to the final design.

The Self-Leveling Stow-Away Pool Table final design consists of a table with a linear actuator in each of the four legs to allow the inclination of the pool table to be adjusted. These will be controlled through the use of a microcontroller which will read the signal on an inclinometer to level the table. The table will also have a steel frame which has large pins on each end of the long

axis. These pins will connect to pin holes on a set of two dollies which will support the full weight of the table while it is rotated 90 degrees along the long axis to the stow-away position.

In order to design a product that is user friendly and marketable, safety was made a top priority. All possible hazards that could occur with use or misuse of the product were taken into account and documented, in detail, to be made available to the user. Once the table is guaranteed safe to use, it can be marketed to the public

In order to satisfy both budget and time constraints, a detailed schedule was made in the form of a Gantt chart. This allows for the team to move along the design process in a manner that is both timely and thorough. The schedule allowed time for the team examine all possible resources and then begin the procurement process. In order to work efficiently, communication was vital between team members, sponsors and advisors. Through planning and communication, the team was able to solve unexpected obstacles as they arose and progress through the design schedule to create a design that was both safe and effective.

2. Background Research

The inspiration behind the design idea comes from two mechanical engineering students Alexander York and Norman Gross who graduated from the FSU/FAMU College of Engineering in 2013. Their Group 19 Senior Design project, led by Alexander York, was sponsored by Beyond Innovation LLC to design a self-leveling pool table that was also “*capable of vertically stowing itself in a discrete housing whenever additional space is needed in the area the table is kept.*” [1] The team last year utilized stepper motors powering tongue jacks located on each of the four legs and a control system programmed with a stabilizing algorithm to stabilize the pool table with just the push of a button. The leveling system done by the team last year proved ineffective as the process took too long to be considered useful. The stowing function of the table last year was to winch the table to a vertical position such that the long end would run into the ceiling of many homes. The costs of the table last year remained under the budgeted amount as shown in Table 1. Budget breakdown for 2013 Sr. Design Team 19. Since, however the final product was not market ready, the project became available for the senior design team this year.

Table 1. Budget breakdown for 2013 Sr. Design Team 19

Total spent	\$2,723
Budget	\$3,000
Funds remaining	\$277

Group 19’s original “Self-Stabilizing Pool Table” (Figure 1) lifts the pool table vertically until the playing surface is perpendicular to the ground and the table is fully in the housing. This product has the potential to be revolutionary because of its wide range of possibilities. It could be of great use to sports bars, hotels and homes. This stow-away pool table is the first of its kind so there is no opposition. There are, however other applications for leveling mechanisms such as for water vessels (Figure 2) and space saving furniture like wall beds. Anywhere that can’t afford to permanently sacrifice the large amount of room needed to comfortably house a pool table can benefit greatly from this design.

The World Pool Association (WPA) is the international governing body for pocket billiards. They set rules for all major billiards tournaments around the world including the World 9-Ball Championship and World 8-Ball Championship. These rules include both game rules and equipment standards. Since one of the design specifications is for the SLSA pool table to satisfy tournament regulations, the WPA rule book was referenced frequently [2]. Regarding the self-leveling system, the WPA rule book says that the playing surface must have “an overall flatness within + 0.020 inches lengthwise and + 0.010 inches across the width.” [2] Another regulation that places a large constraint on the SLSA table design is that the playing surface must be made of slate which can weigh up to 250 lbs and will cause the table to be very difficult to lift.

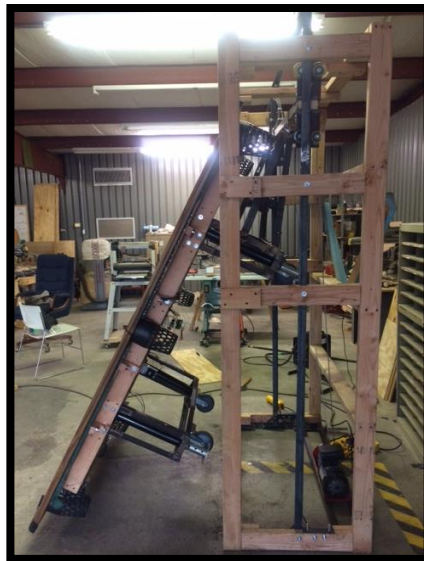

Figure 1. Group 19's original prototype [1]

The self-leveling feature on a pool table can be seen in one other design that exists. A Royal Caribbean cruise ship called The Radiance of the Sea [3] features a pool table with an active leveling system to keep the playing surface level while the cruise ship moves. The issue with this design (Figure 3) is that it is permanently fixed to the ground and extremely expensive with a unit cost of \$80,000. This design uses a gyroscope to continuously level the system. Since the SLSA table will not have to be continuously leveled, the leveling system can be relatively simple and inexpensive compared to the gyroscopic table. Although it is beneficial if the table is inexpensive, it is still important that the table has equipment that is sophisticated enough to satisfy the requirements of the World Pool Association. This, along with affordability, will allow for the SLSA to be a strong competitor in the pool table market.



Figure 2. David Hall's self-leveling boat platform



Figure 3. The Gyroscopic Pool Table located on Royal Caribbean's Radiance of the Sea

3. Concept Generation

The overall concept of our final product has been a continuous development throughout the course of the school year. Although our project is based off of last year’s stow-away pool table, the new goals for this year is to improve the overall quality of the table which required us to come the team with new design concepts and begin from scratch. The team brainstormed and were able to come up with three distinct design concepts. Using the decision matrix Table 2 found below, it was made possible to select the best design concept for completing the project based on objectives from the designs shown. The scores for the individual decision matrices were averaged together for each design to get the team average stow-away design decision matrix. The final scores were very close but Design #1 came out slightly on top and also involves the housing desired by the sponsor Alex York.

Table 2. Team Average (Rounded) Stow-away Design Decision Matrix

Decision Criteria								
	Safety	Low Cost	Ease of Manufacture	Visual Appeal	Familiarity	Design Simplicity	Footprint Reduction	Total
Weights	3	2	2	3	2	1	3	N/A
Design 1	3	2	2	3	3	2	1	37
Design 2	2	3	3	1	3	3	2	36
Design 3	2	2	2	2	2	3	3	36

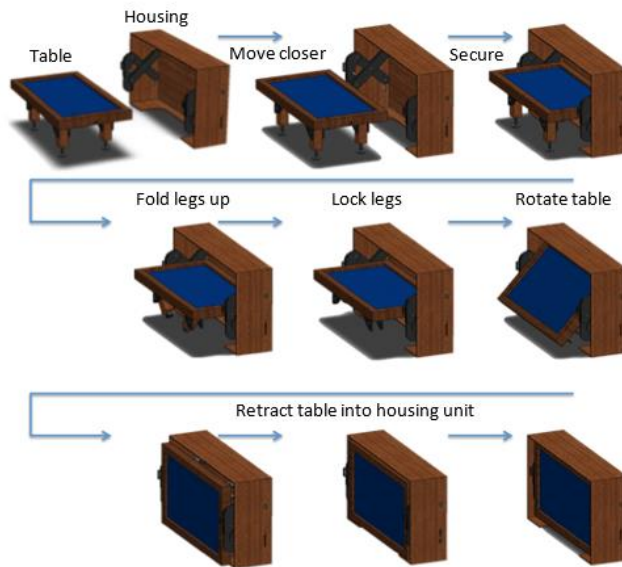

Figure 4. Design Concept #1

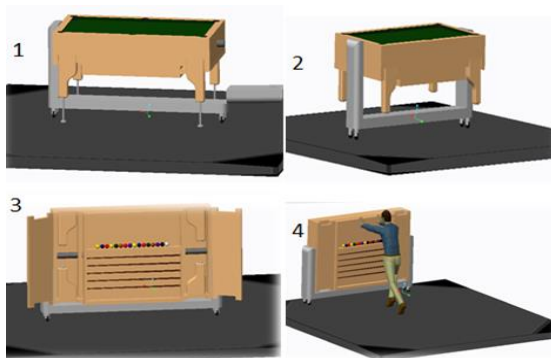

Figure 5. Design Concept #2

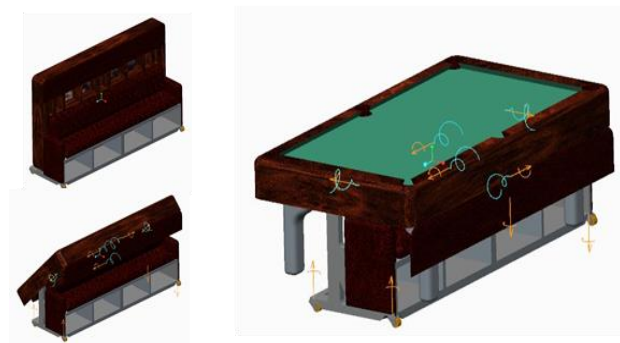

Figure 6. Design Concept #3

The chosen final design was altered multiple times compared to the original one decided on last semester, but luckily we have not had to modify it much along the way. Time was taken during the designing stages, attempting to consider as many possible factors pertaining to topics such as safety, ease-of-use, marketability, and the possibility of mechanical failure. It was desired to make sure that the product would be perfect and that the design was well thought-out. It was important to choose the best components/design for each portion of the pool table, even when it came to the electronics being selected for self-leveling system. Again, decision matrices were used for choosing the best components to fit the needs as well as the future customers' interests. The final proposed design resulted in being a partial merging of two of the design concepts since the team kept the general table design from the selected Design Concept #1 but ended up using dollies to move the table somewhat like Design Concept #2. More details pertaining to the final assembly and the modifications made to specific portions of the designs can be found in this next section, which focuses on the complete final design.

4. Final Design

The Self-Leveling Stow-Away Pool Table is comprised of 4 major types of assemblies: the frame, rail assemblies, leg assemblies, and dolly assemblies. In addition to these assemblies, the pool table also requires a clothed slate, wood aesthetics and a mechatronics system. The final design for the pool table is a result of intensive designing, from which was derived from our original design concepts. Each of the subassemblies that the table is comprised was continually modified along the way, in attempt to create the best product thus far. Dimensioned drawings of every part of the entire system can be found in Appendix. It was necessary for the final design concept to incorporate the marketability aspect.

4.1 Marketability

The stow-away table is perfect for bars, restaurants, and hotels looking to make the best use of their property by being pool halls by day, and at night having the ability to create room for a dance floor, dining tables, etc. This product is also great for those who cannot afford to dedicate an entire room in their homes to a pool table. Two additional features make this product stand out from the competition: the table stows into a cabinet that blends in as furniture, and the height of the table can easily be adjusted to make it easier for children to play.

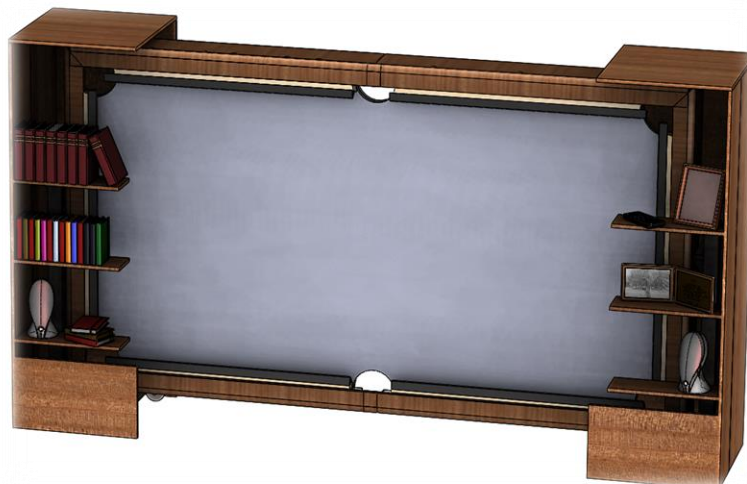

Figure 7. Final Design Concept
(Entertainment System Housing)

4.2 Components/Subassemblies

4.2.1 Frame

The frame was one of the most important components of the table. It needed to be capable of supporting and securing the 300 lb. slate in both the playing and stow-away positions. The frame itself was constructed out of reinforced steel which required cutting on the bandsaw and welding. The frame holds the slate in place even while it is being rotated. This is made possible by clamping the slate between the bottom of the bumper and the top of the frame as illustrated in the rail assembly section.

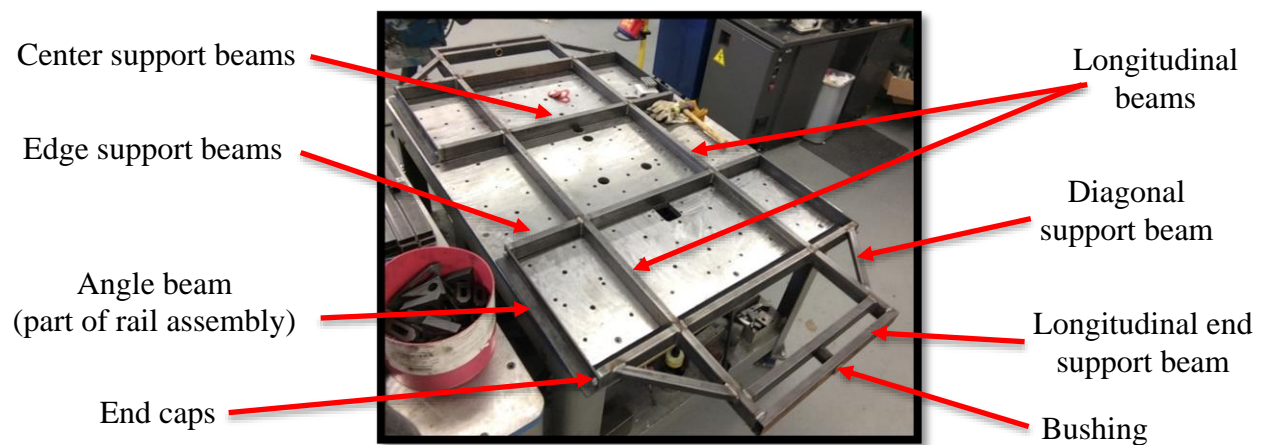

Figure 8. Frame composed of hollow steel tubing

4.2.2 Rail Subassembly

The rail assembly attaches directly to the pool table frame by means of an angle beam, end cap and nuts/bolts. It was designed to be easily removed for installing/repairing the slate or slate's table cloth by simply removing just a few bolts. The rail assembly is also designed to provide safe support to the slate when in the stow-away position. Another design feature of the rail assemblies is the quick and easy ability to remove/replace the bumpers as illustrated in Figure 10.

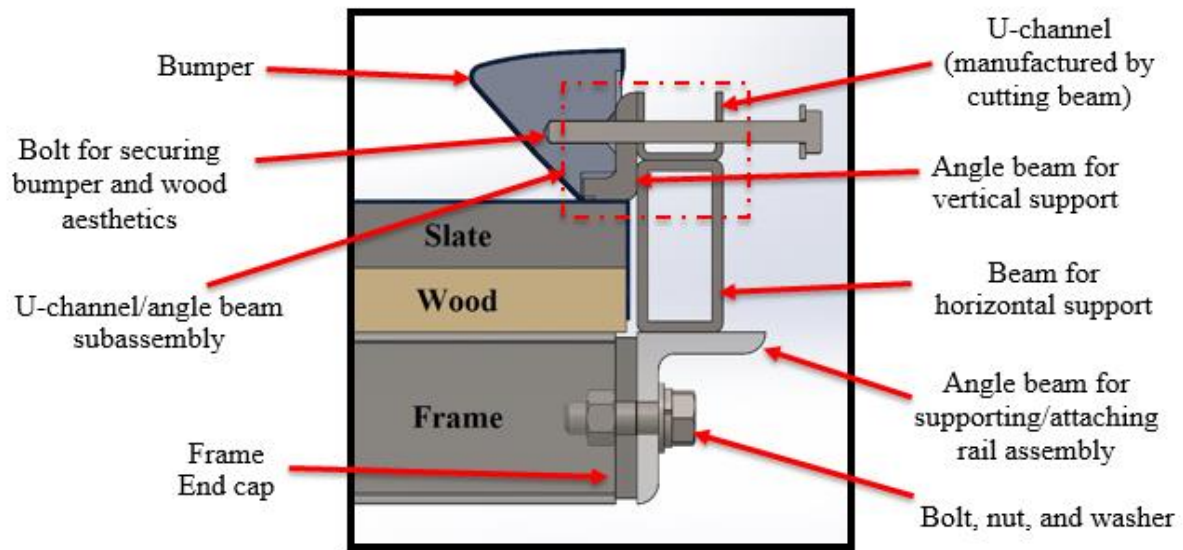

Figure 9. Rail Assembly

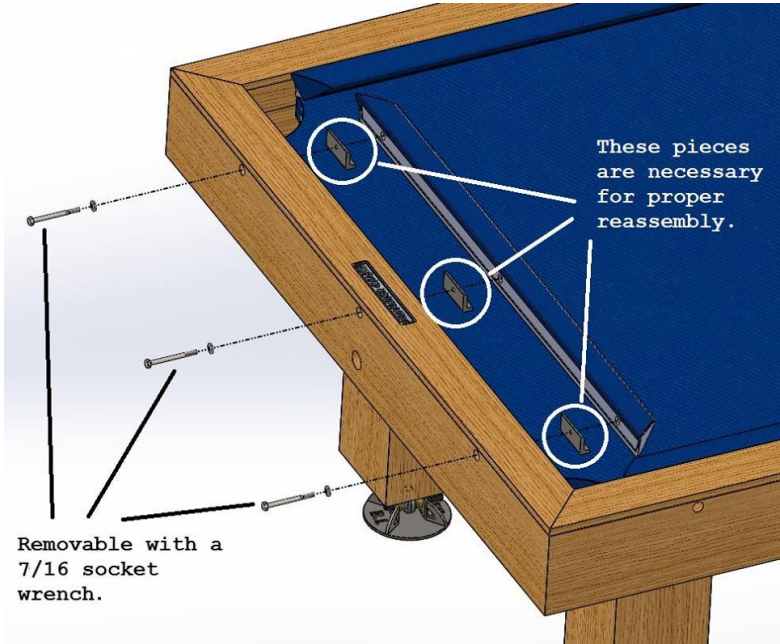

Figure 10. End Bumper Removal (Top) and Side Bumper Removal (Bottom)

4.2.3 Leg Assembly

The leg assembly provides as a frame for the linear actuators with which will raise and lower the table. The assembly attaches to the frame with hinges, allowing for the legs to fold when stowing away the pool table. A visual breakdown for the leg assembly can be seen in Figure below. There are four leg assemblies total.

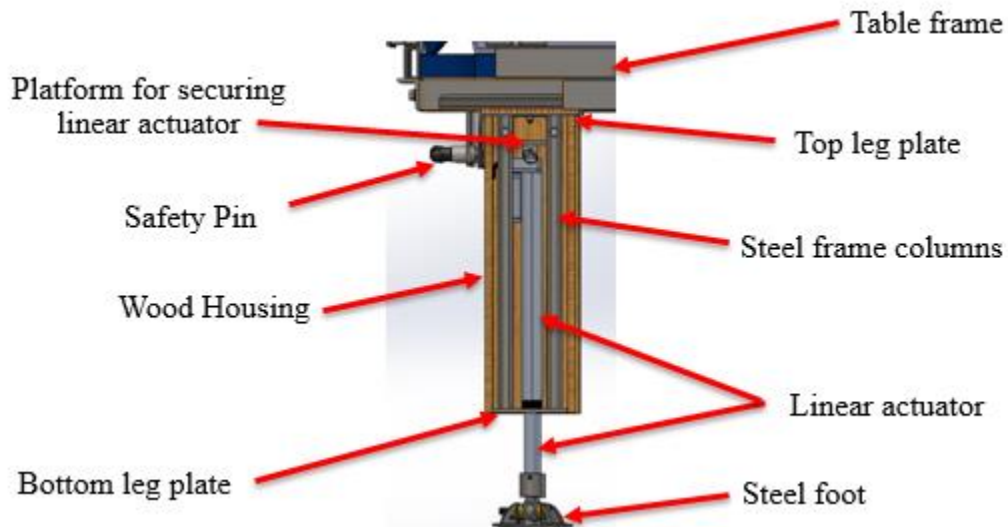

Figure 11. Leg Assembly

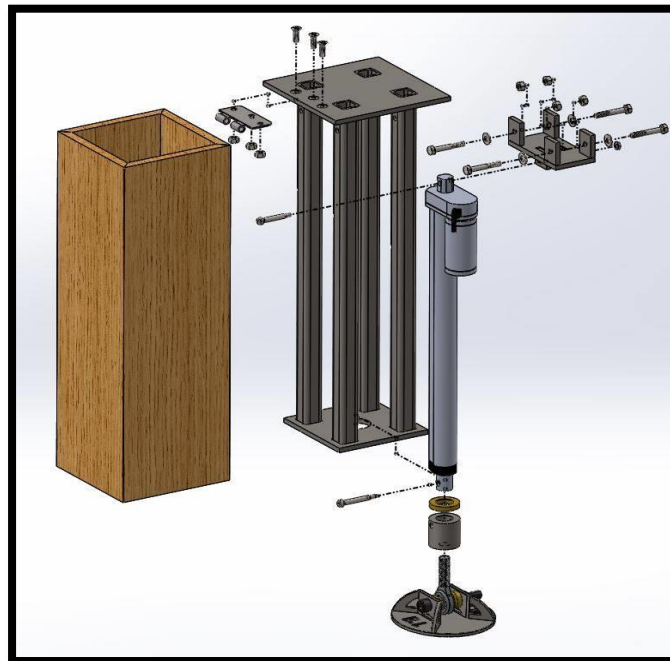

Figure 12. Leg Assembly Exploded View

4.2.4 Dolly Assembly

The dolly assemblies are designed and manufactured to support the total weight of the pool table and are necessary for the stow ability of the table. There are two dollies (one for each end of the table) and each are on 3 dual caster wheels for the sake of movability. The dolly assembly is simple and is broken down into components in Figure 13 and Figure 14.

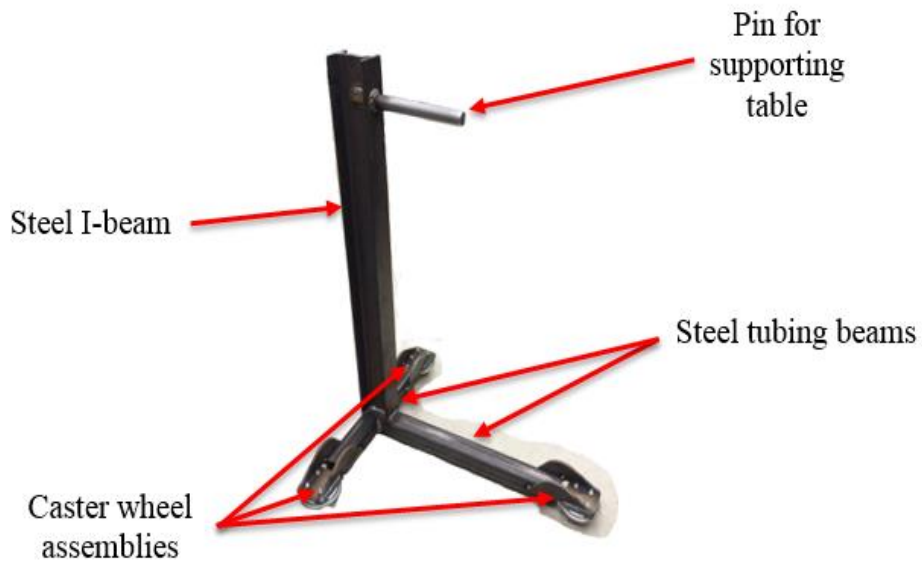

Figure 13. Dolly Assembly

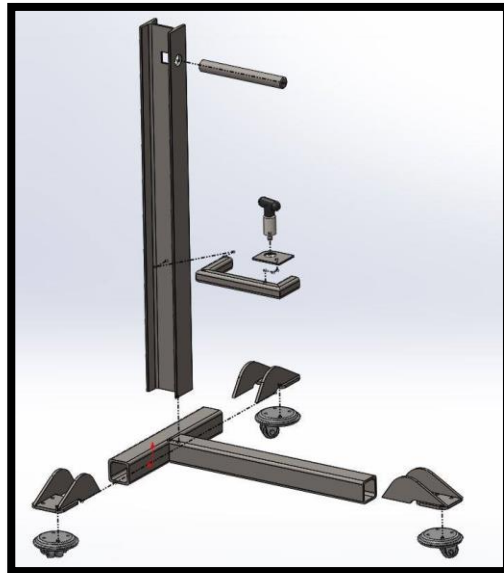

Figure 14. Dolly Assembly Exploded View

4.2.5 Self-Leveling System

The self-leveling system uses an Orangutan X2 microcontroller which reads a signal from a 2-axis inclinometer. The microcontroller then sends signals to two Atmel VNH2SP30-E dual-motor drivers which control four linear actuators located in the leg. These linear actuators raise and lower the pool table. At the end of the linear actuators are the feet of the pool table which utilize press sensors to maintain contact with the ground. Each leg has a steel frame to house its linear actuator. A control panel with an LCD screen and three buttons are used to scroll through various options which allow the user to set the table to autolevel or manually adjust the table height and inclination. The table designed to be already calibrated to level properly but it may be recalibrated if needed. There is also a power button and a reset button.

In order to level the table as quickly as possible, the program logic must be detailed and efficient. Controlling each linear actuator simultaneously will allow for the table to level both the longitudinal and latitudinal axis at the same time. The two dual-motor drivers coupled with a two axis inclinometer makes this feat possible. The programming logic flow chart can be seen in Appendix B.

4.2.6 Wood Aesthetics

The woodworking for the table is outsourced for the sake of providing the customer with a high quality pool table appearance. The purpose of the wood aesthetics is to cover up all the steel and make the table look and feel like a standard, elegant pool table. As stated from the very beginning, the product must be as traditional and eye-appealing as the typical pool table. It's important to both the feel and marketability of the table.

4.2.7 Full Assembly Exploded View

The assembly of the pool table is very simple once all of the other subassemblies have been manufactured. A simple illustration of the general assembly of the multiple components to create the table as a whole can be observed in Figure 15.

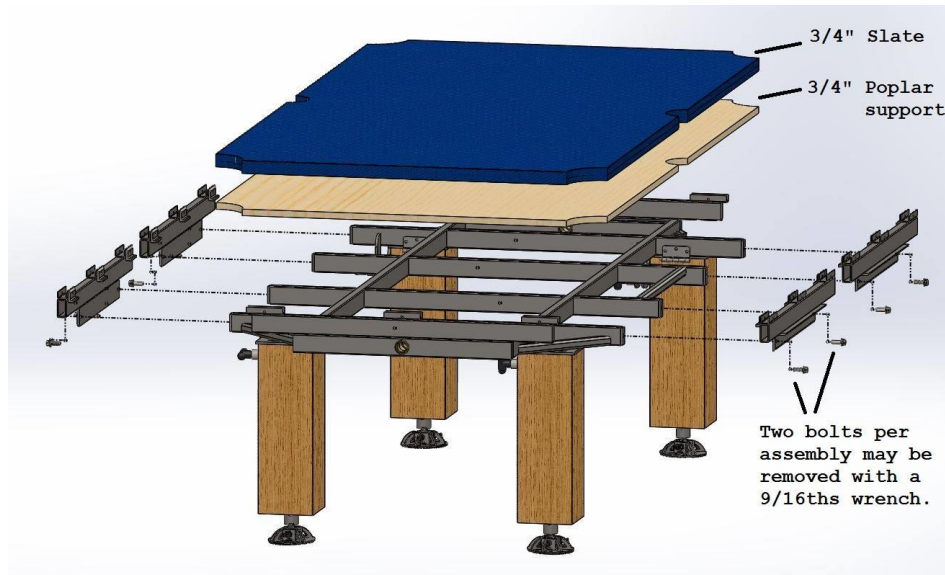

Figure 15. Final Design Exploded View

4.3 Operation

4.3.1 Stowing Procedure

Before beginning the stow-away procedure, there are a few safety protocols that must be taken. First of all, remove all objects from the surface of the pool table. Second, choose an area which the pool table will be placed once in the stow-away position. Finally, make sure that the table will be able to fit. There must be a 29 in. wide and 70 in. tall clear path, free of any obstacles, for the pool table and dollies to travel along while being stowed-away.

The following steps are for placing the pool table into the stow-away position. To ensure safety, exercise caution and closely follow each step as directed:

1. Plug in the power and press the “On” button, select a manual mode, positive speed and then hold the actuate button until the table is raised so that the center of the pinhole is 32 in. above ground.



Figure 16. Dollies lined up with table

2. Roll the dollies to each side of the pool table and check that the center of each pin is at the same height as the table pin holes.
3. Roll the dollies so that the pins go fully into the holes on the table and insert the pin lock.
4. Select a negative speed and hold the actuate button to retract the legs fully.



Figure 17. After pins are inserted into table and feet are retracted

5. Rotate the table slowly until it comes in contact with the safety stops on the dollies and lock into place using T-handle locking pin. Make sure that no one is in the way of the rotation including any of your own hands and feet.

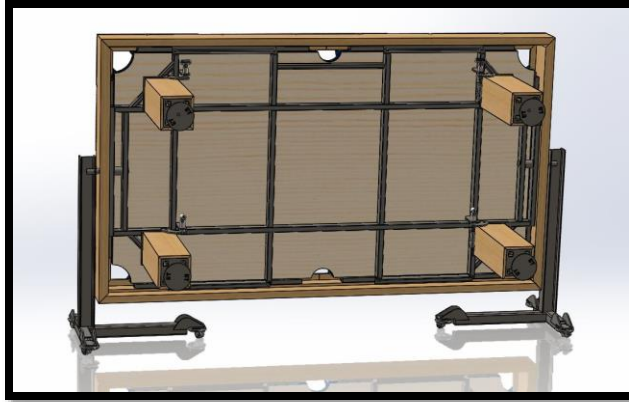

Figure 20. Table after rotation into locking

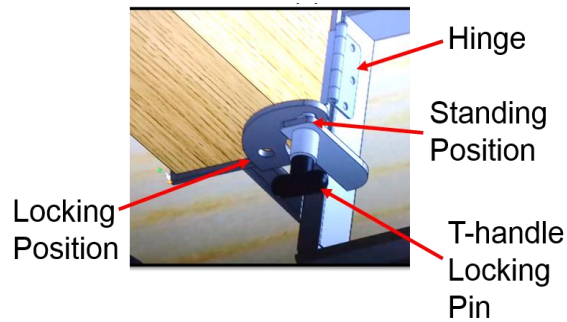

Figure 18. Folding Leg Locking Mechanism

Starting with top legs, pull the safety pin and push the legs inward until they are parallel

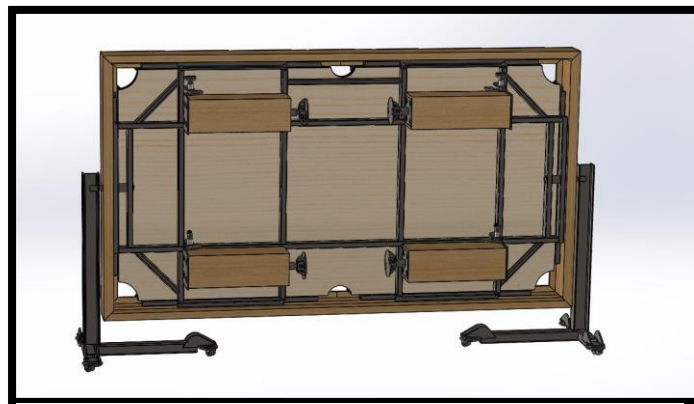

Figure 19. Table in stowed position, ready to move with the table and the safety pin latches back into place.

6. Move the table to the desired location by grasping the column of the dolly at about the same height as the pin and pushing slowly.
7. To bring the table back out for play; perform the reverse of these steps.

4.3.2 Leveling Controls

Auto Level

The following steps are for the auto-leveling feature of the table. Before beginning these steps make sure that all four legs of the table are locked in the folded out position and pointed towards the floor and remove any objects from the surface of the table.

1. Plug in and turn on the power. Select “Auto-level” on the control panel
2. Refrain from leaning or placing any weight on the table during the leveling process.
3. Once the table is finished leveling, make sure that it is actually level by testing with a bubble level or rolling a ball along the playing surface.
4. If the table is not level after repeated tries, the inclinometer must be recalibrated.

Inclinometer Recalibration & Manual Adjustment

Inclinometer recalibration should only be done if the auto-level function is malfunctioning. If issues persist after recalibration, contact the manufacturer for further assistance. The following steps are for the recalibration process.

1. On the control panel, select “Manual Mode.” This mode allows you to manually raise or lower the linear actuators. Select to control individual actuators or pairs of actuators.
2. Adjust each leg as needed until bubble levels indicate the table is level. Note that if the table is on carpet, this may have to be redone after it settles.
3. Allowing a pool ball to roll down a ramp and observing its path may be more accurate than most bubble levels. If such accuracy is desired, roll a ball from each side and raise the area of the table the ball curves toward.
4. Once the table is level, return to the main menu on the control panel and press the “Level to” button 5 times to set inclination of the pool table as the program’s new “level” position.
5. Manually controlling all four actuators at once allows for the height of the pool table to be adjusted but the DC motors in the actuators are not perfectly equal so the auto-level function should be used after the height is adjusted.

4.4 Dimensions/ Tolerances

4.4.1 Leveling Tolerances

As stated earlier, the World Pool Association sets a standard of playing surface flatness to be within ± 0.020 in. lengthwise and ± 0.010 in. across the width. This is an incredibly small range with the angle of inclination needing to be $\pm 0.014^\circ$ for both the longitudinal and latitudinal axes, as seen in Fig. 22 and Fig. 23. This tolerance is important when it comes to selecting an inclinometer and microcontroller to use for the self-leveling system. The inclinometer must be sensitive enough to be able to detect a change in inclination within the desired range and the microcontroller must have

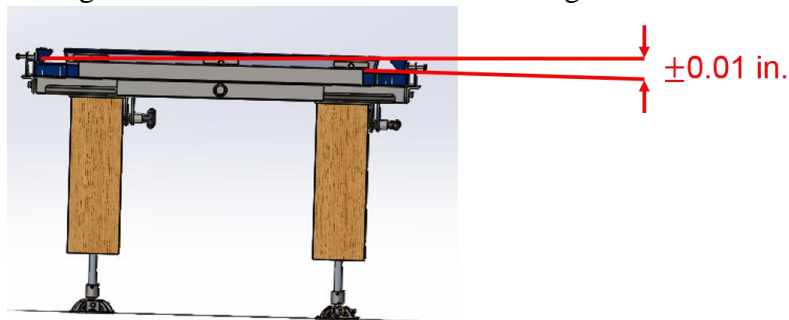

Figure 22. Angle Inclination along Latitudinal axis

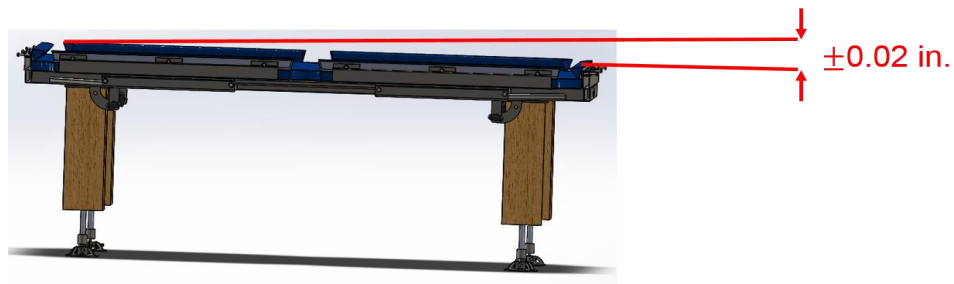

Figure 21. Angle Inclination along Longitudinal Axis

a high enough resolution to be able to obtain data values from the inclinometer within the desired inclination tolerance. The two-axis inclinometer selected for use in the self-leveling system was chosen because it satisfied the tolerance requirements. In order to determine this the following calculations were done with help from Dr. F. S. Alvi's lecture notes on uncertainty analysis [4]. The sensitivity (s) of 200 deg/mV and output voltage range (ΔV) of 0V to 5V for the inclinometer were given by the manufacturer and used in Equation 1 and Equation 2 below to find the voltage tolerance (Tol_V) and the number of subdivisions (Sub) needed for the processor.

$$Tol_V = s * Tol_\theta = 0.0055 V \quad (1)$$

$$Sub = \frac{\Delta V}{Tol_V} = 916.3 \quad (2)$$

Tol_θ represents the angle of inclination tolerance which was previously described. Once the number of subdivisions was calculated, the necessary analog to digital converter resolution (N) was calculated using Equation 3 below.

$$N = \log_2(Sub) = 9.839 \quad (3)$$

With the results of Equation 3, it was then determined that a 10-bit or higher resolution was needed for the analog to digital converter on the microcontroller. With a 10-bit ADC, the Orangutan X2 was determined to be ideal for this usage.

With analog to digital conversion come a digitization error which is caused by the precision of the device taking the measurement. This digitization error (δ) must be within in the voltage tolerance range of 0.0055 volts that was calculated in Equation 1. In order to calculate the digitization error, the least significant measurement bit (LSB_{10}) for the 10-bit ADC must be known. This was calculated using the following equation:

$$LSB_{10} = \frac{\Delta V}{2^N} = 0.0049 V \quad (4)$$

With the least significant bit calculated, Equation 5 was used to calculate the digitization error for the inclination data.

$$\delta = \frac{LSB_{10}}{2} = 0.0024 V \quad (5)$$

The digitization error was smaller than the required voltage range of 0.0055 volts so the inclinometer and the OX2 microcontroller were determined to be suitable for use in the self-leveling system.

4.5 Finite Element Analysis

The product ultimately consists of two dollies and one table, which are three independently movable parts. The system can be analyzed in two of its configurations: the stowed and the free-standing configurations.

When the dollies are separated from the table (free-standing configuration), the weight of the table is held by its own legs. Initial tests showed that the weight bearing capabilities of the legs were sufficient, and correlate with the expected results, however, there is noticeable flex on the linear actuators' shafts when the table is set up higher than the usual 30 in. playing height. Although the operations manual advises users against lifting the table higher than that except to begin the stowing process, there is a possibility for the shaft to buckle under conditions of misuse. Additionally, the back and forth radial deflections of said aluminum shafts could theoretically create a long-term material failure due to fatigue (cyclic loading), but at the highest stress below aluminum's yield strength, its endurance limit is 10,000 cycles. If the table were to be moved once per day, it would take 27 years to surpass the aforementioned limit.

When the table and dollies are joined together (stowed configuration), the weight of the table is supported by dollies rather than the legs. The weakest part of the dollies are the 1 in.-diameter steel pins. A finite element analysis (FEA) was performed using Dassault Systemes' Solidworks simulation package, where the wheels are assumed to be fixed, the entire assembly bonded, and the shaft loaded vertically with 300 lbf. As seen in Figure 6, the highest Von Mises stress is found near the pin-beam intersection on the top side, where the material is deformed in tension. It is important to note the deformation is scaled to 112 for visual purposes. Considering a mild steel yield strength of 36,000 psi and a maximum stress of 13,000 psi at the pin, we arrive at a factor of safety of 2.7. Lastly, we followed standard procedure for refining the mesh and found no significant variation in the results when increasing elements past the automatically generated size.

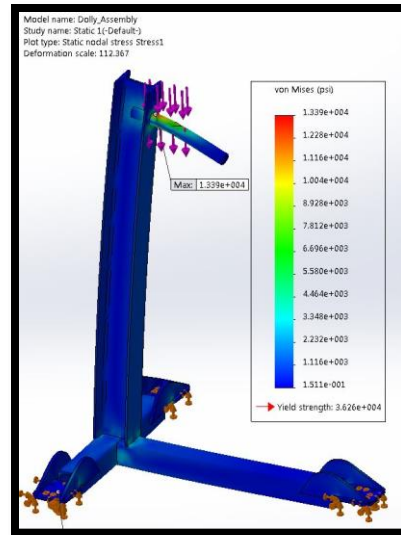

Figure 23. Dolly FEA

Following the manufacturer’s caster wheel load rating of 264 lb., and making an even-distribution assumption, the three-caster setup of the dollies provides a factor of safety of 2.6 under the same 300 lbf used in the FEA described above.

The steel skeleton is reinforced in key areas. Since the bushings are the point of contact between dollies and table, the tubing that holds them is supported by the diagonal braces on the corners of the frame. Due to its abundant availability, we used 1 in. square tubing of 0.12 in. wall thickness. It was noted by faculty and staff that future iterations of this frame need not bracing of such thickness, since it can be seen with the naked eye that the structural support provided by the bracing is justified only under much larger loads. The recommendation was to source thinner tubing in order to save weight while still adding rigidity to the frame.

The dollies and frame are connected by its pins and bushings respectively. It is well known that smooth operation of low speed rotating components can be achieved with bushings, as opposed to roller bearings, and that a brass-steel interaction decreases component wear over time. Considering that this product will not be used in a lab environment (with strict maintenance procedures), we selected oil impregnated bushings to keep the friction low without the need for the user to follow a lubrication schedule. Additionally, every time the dollies are connected, the pressure between the components makes an imperceptible but sufficient amount of oil to seep out onto the pins, effectively adding a coat of it which acts as protection against rust.

There are questions regarding the longevity of corroded parts whenever components are made of carbon steel. To address that concern, paint is applied to all steel surfaces that are exposed to the elements. After some deliberation, it was decided that a powder coat method of painting—although more costly- was justified. The paint job was outsourced for this first prototype, but could be implemented as an in-house procedure when the production output is scaled to multiple units per month as a justified expense with quick return on investment.

4.6 FMEA

There were three important occasions when the team was faced with the possibility of the project or system failing. In order of severity: dolly material failure, fabrication tolerances too small for the user's comfort when performing maintenance, and poor fitment of wooden pieces. Following the advice from experienced fabricators Jeremy Phillips and Stephen Avery, appropriate steps were taken to reduce the risks associated with the problems described here. Using industry-standard Failure Mode Effect Analysis procedure, the situations is described in tabular format in Appendix C. As of the date of this report, all actions taken have resulted in much lower risk as expected.

5. Design of Experiment

The common practice for testing components whether electrical or mechanical in nature was to test the part in its original “as delivered” state to make sure it worked as advertised. As a mechanical part example, hinges were delivered to us that would not fold to 90° and were powder coated so they required cutting and grinding to fold to the required extent and be ready for welding. The electronics mostly worked as advertised but of course required programming.

5.1 Electronic Component Testing

Testing of much of the electronic components occurred during the fabrication of the frame of the table and the legs and testing of some of the mechanical aspects also overlapped with the electronic testing.

5.1.1 Orangutan X2, VNH2 Motor Drivers & Linear Actuators

The Orangutan X2 (OX2) was delivered fully assembled with the dual VNH2 motor driver, 5 buttons, LEDs and a 16x3 input/output (I/O) port block for wire connections already soldered to the board. It also came with initial programming which allowed for testing all of its components. To test the as arrived condition, we plugged in two linear actuators directly to the motor driver connections and the 12 volt power supply from an AC-DC adapter through a breadboard to the power connection on the motor driver. Running the factory set program completed testing for not only the OX2 but also the adapter and linear actuators. We had four of those linear actuators so to test the other two, we simply plugged them in instead of the first two and learned that each actuator responded to the signal given to it slightly differently.

5.1.2 Initial Programming

Initially connecting the OX2 to a computer required specific drivers and multiple programs required downloads in order to begin programming. These included AtmelStudio6 and AVRdude plus some programming libraries specifically for the OX2. Links to everything required and specific directions were included in the Orangutan X2 Resources tab [5] on the Pololu website. With extensive time put in to learning how to program specifically for the OX2, looking through the resources provided by Pololu and testing pieces of their provided programs combined into one,

manual button control of the two linear actuators was achieved. Then further learning and programming continued for controlling the second motor driver in order to manually control four actuators at the same time with the three available buttons (Power and Reset/Program not included).

5.1.3 Second Dual VNH2 Motor Driver & Simultaneous Actuation

The second dual motor driver was delivered separately and required a pin line to be soldered to it so that it could be plugged into a prototyping breadboard. Using the Orangutan X2 Robot Controller Quick-Start Guide, Orangutan X2 Command Documentation provided by Pololu and extensive help from Dr. Gupta for being able to read, understand, and implement both, along with some trial and error, the correct connections were made and the code implemented to control the second dual motor driver via the 16 user I/O ports provided by the Ox2. The linear actuators would not initially move all at the same rate when given the same signal so many hours were put in to iterate testing different signal amounts for each actuator for three different speeds to get them all going at the same rate for each speed. This all had to be redone when we switched to longer stroke linear actuators to fix a clearance issue for the stow away function but before that, there had to be a smart way to use only 3 buttons to control the actuators in all the ways we wanted.

5.1.4 Programming Menu Selection

Further research into the resources provided by Pololu including asking questions in the forum and several versions of the program were tried before finding a more user friendly negotiation between menus and for safer activation of the actuators. As an example of a change made for safety reasons, when two separate buttons were initially programmed for actuating in two different directions, the sudden switch from one direction to the other in the higher speed mode would shut down the OX2 so one button was set to change the speed cycling through positive and negative directions and one button (the “actuate” button) was set to activate the actuators at that speed. The third button in the end was set to cycle through which actuators would be activated by the “actuate” button or change to a different menu. Finally after this, the “auto-level” function and recalibration function were created and given their own buttons on the primary menu while the manual modes would be selected from a menu arrived at by a third.

5.1.5 Inclinometer Sensor Input, Auto-Leveling, and foot buttons

To start the auto-level function, first research was done on how to set up the analog input ports and connect the inclinometer. Initial testing for the inclinometer simply sent a 0 – 1024 digital output reading to the LCD screen from the 0 - 5 Volt output of the inclinometer. The choice for this range over the 0-256 range is for better precision which is required for the game of pool. In order to test the auto-level function, the four original 6 inch stroke linear actuators were zip tied to a small square metal platform with 4x4 wood posts for legs provided by Dr. Gupta. This testing mechanism is shown in Figure 24.

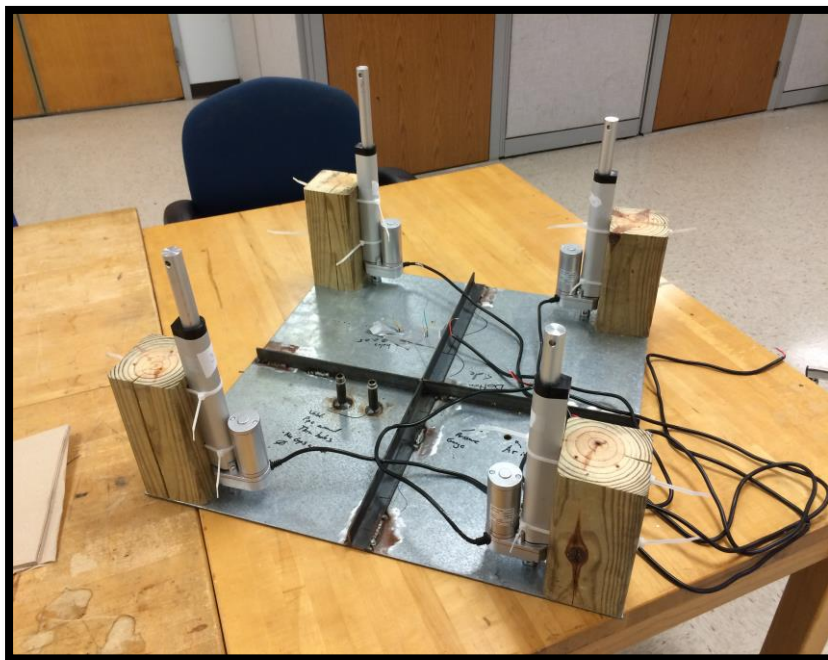

Figure 24: Self-Leveling Testing Mechanism

Quite a lot of time was put in, trying to get the program to actuate the legs up or down to bring the table to a central reading between 0 and 1024 which had to be calibrated depending on how the inclinometer was mounted to the platform. Eventually a very simplistic program was arrived at which only raised the corner of the platform indicated to be the lowest by the inclinometer. This seemed to work quite quickly and did bring the table to a level orientation but sometimes it would reach “level” using only three legs and the fourth would be left with its foot up in the air. Though the actuators we selected could handle the weight of the table with only three of them, it would not be preferable or safe because the table could pivot if pressed down on the end with the foot up in

the air. Some thought went into programming differently to solve the problem but eventually the decision was made to put buttons in the feet to sense when they are touching the ground and simply program any leg with a foot not touching the ground to extend until it did. Four of the remaining I/O ports on the OX2 were used for inputs of four button press signals powered by a 5 volt regulator connected to the 12 volt power source and tested well with good response times.

5.1.6 Problems in the testing phases

It is surprisingly easy to destroy the OX2 as careful as one might be to not step on it, a simple connection to ground from the wrong place or faulty power connections can and did render an OX2 useless. 2 OX2s were destroyed and their parts repurposed over the course of testing. A 5 volt regulator was also ruined and at one point a fair amount of work on the program was lost due to a computer failure. Backups of the program were being saved regularly to online storage but after the crash, the program was redone and automatically updated to the online storage every time work was done on it so that it wouldn't happen again.

5.1.7 Infrared Range Finder

The IR sensor output a voltage inversely related to the distance of an object so testing was performed using a white surface as well as a dark surface to find a suitable conversion equation to convert the output to inches within the range we are dealing with (between 15 and 30 inches). The difference between surface colors was minimal considering that our accuracy for reading the height of the table is merely for user reference to adjust to a preferred playing height.

5.1.8 Testing the actuators on the frame without slate or wood

After the new longer stroke actuators were obtained, the signals for the 3 different speeds were calibrated for each one to match the others. The frame, legs and feet were ready for the actuators to be attached soon after and testing of the program in all its modes began with just the frame without the slate or wood attached. In this test we discovered that while the actuators were running the inclinometer reading was lower than when they were off. Also some of the legs would run slower than they were without the weight. This led to the realization that our power source was not strong enough to handle the 3 amps pulled from each actuator running at the same time plus a small amount drawn by the sensors and processor. Further testing with the new power source is

still required and may still result in other problems causing the auto-level function to not work to the standards we desire. Also due to manufacturing differences between DC motors any time an actuator is replaced, calibration in the programming is required for running them at the same speed simultaneously. Further testing and analysis of the electronics is recommended before a final product can be manufactured reliably for customers especially for the auto-level function but the manual operation is quite effective.

5.2 Mechanical Component Testing

Beyond the extensive preparations for CAD modeling including advisement from the machine shop, before each part was added to the assembly, its alignment and function was tested to work properly.

5.2.1 Frame Components

Welds in the steel frame were tested to be strong as they were applied before each new component was added and the entire frame assembly made from rectangular steel tubes was tested for any amount of bending. This was done by simply leaning on and adding weight to one side of the frame while the other is supported. No deformation was expected and none occurred but we did not test unreasonably to breaking point as the frame is only required to hold the slate firm and flat. The wooden backing with the slate were set on the main part of the frame while the braces were set in position for welding to make double sure of the measurements allowing for the slate to be removed but still held snugly with the felt and wood backing. The same alignment testing was done for those braces to have bolt holes align perfectly with the threaded bolt holes in the rails.

5.2.2 Leg Components

Initially designed to hold the shorter stroke linear actuators, the leg frames were designed to allow for the actuators to be removed for replacement. This made it easy to adjust the design to the new longer actuators which matched the smaller ones in many of their dimensions. We used the actuators in place while setting up the position of the holding tabs to be welded.

5.2.3 Feet, Carts and Locking Mechanisms

Welding of the tabs on the feet to hold the foot buttons took considerable alignment testing as the small size of the buttons required great precision and custom fit to each foot. The feet were also

tested with the electronics to remain flat on the ground. The carts were tested to hold the weight of the frame without wood and slate first and adjustments were made on the pins for smooth insertion into the frame. The frame rotation on the cart pins was tested with and without the legs before adding the wood and slate. With the legs extended, the feet have good clearance over the carts and the balance is as expected without the slate and wood. The rotation is wonderfully smooth and slow so that it does not swing and rotate out of control but remains steady. Locking mechanisms were tested to align properly between the carts and frame as well as between the legs and frame before clamping them in place for welding. The carts carrying the frame without slate and wood were also tested in rolling over small imperfections on concrete (about a centimeter or quarter inch step downwards). This is to simulate movement from tile or wood flooring to carpeted flooring and back in a house. If anything larger is being traversed, the user is expected to have the table hand carried preferably by two or more professional movers. Rolling of the carts with the frame without wood and slate is tested to be easily done by a single person. We do not expect results to be too different after the slate is added but further testing is required. Some anticipated fixes may be larger wheels and support flanges on the carts for rolling over less smooth surfaces such as tiles, door jams or thick carpet.

6. Project Management

6.1 Schedule

The first step of the design process for the SLSA pool table was to create a detailed schedule. On this schedule, there should be an allocation of hours between team members, objectives assigned to team members and an expected completion date of each objective. It is important to break large goals into smaller short-term objectives in order to ensure that every detailed is covered. The schedule was created in the form of a Gantt chart. The comprehensive Gantt chart for the entire design process can be found Appendix D. The project objectives were split into two subsections: electrical system and structural support. The electrical system consists of all of components that make up the self-leveling system such as the linear actuators, the microcontroller and all wiring. The structural support consists of all components which give the table support during the stow-away process. This includes the steel frame, the dollies and the legs.

Although the Gantt chart was created with the intent to follow it strictly, unforeseen circumstances occasionally caused the team to veer of course a bit. When these obstacles arise, it is important to alter the schedule accordingly to completely resolve the situation in a timely manner. Once the problem is fixed, the schedule must be adjusted in order to accelerate the work to catch up back to the original plan. The main problems that caused the team to veer off schedule were parts not being delivered in time and parts breaking such as one of the linear actuators having a motor burn out and the microcontroller being damaged due to a mistake with wiring. Changes in the design to suit unforeseen obstacles also caused the team to not follow schedule. The biggest change was switching from a cabinet stow-away system to a dolly-based stow-away system. Redoing calculations and ordering new parts delayed the progress of the design process. Extra time for designing and building was given while making the schedule. However, not enough time was designated for the accumulation of delays that occurred. This lead to the team having to reduce the amount of time that was set aside for final prototype testing to allow for them to finish.

6.2 Resources

Since the SLSA pool table was a relatively large design, a large workspace was needed to build it. In order to accommodate this large design, a warehouse located on the campus of Tallahassee

Community College was leased out for the year. The warehouse allowed for plenty of space for the team to work on building the table and also store the design that was built last year. Also available for use was the FSU/FAMU College of Engineering machine shop. In the machine shop, were various drills, water jets and other equipment that was used to cut parts and weld or drill them.

These resources were used extensively to create a high quality product. The only issue that occurred was scheduling time in the machine shop for the machinists to construct parts for the table. With many other projects that were being worked on in the machine shop, the machinists had very little time to work on the SLSA design. It was important that the time was used effectively and that the construction was done right on the first attempt because there was very little time to fix any mistakes.

6.3 Procurement

The budget allotted by the SLSA pool table sponsors was \$5,000. Figure 25 shows a breakdown of how that budget was spent. Of the \$5,000

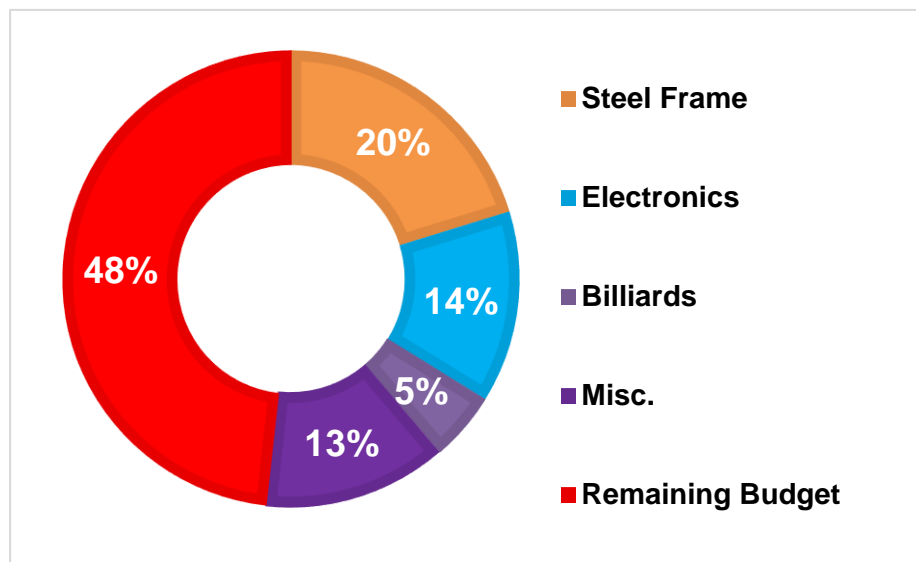

Figure 25. Budget breakdown for the SLSA Pool Table

The majority of the budget was spent on the steel frame because providing support and maintaining safety is vital when operating such a heavy piece of equipment. The billiards section includes all of the components which contribute to actually providing a joyful playing experience for the user.

This includes the bumpers, pockets, cloth and sights. With 48% of the budget still remaining, there is still plenty of potential to increase the overall value of the pool table while still keeping the cost of the table relatively low.

The budget was handled appropriately in order to minimize the total cost of the design. Before ordering a part, various sources for that part were compared in order to get a part with the necessary specifications for the lowest possible price. Another method used to reduce cost was partnering with other Senior Design teams and placing orders together if both teams wanted to order the same part or material. The full bill of materials for the entire project can be found in Appendix E

6.4 Communication

As previously mentioned, communication is vital to success with any team project. In order to ensure proper communication was maintained at all times, various forms of communication were established. In order to share files with the team, a group online Dropbox account was created so that a team member could upload or access a file at all times. This made working on deliverables easy for the team while they were unable to meet.

Communication that required a sudden response was typically done through text messaging throughout team members. This includes casual, or messages of low importance. All formal communication with sponsors and advisors was done through email. Each team member and the sponsor was included in any formal email to ensure that everyone was on the same page. Communication through email allowed for documentation of all interactions. This includes order requests, and meeting scheduling. Biweekly meetings were conducted with team and their advisors. These meetings allowed for the team to keep their advisors up to date with their current progress on the report. Advisors could suggest solutions to any problems, warn of any possible troubles and answer any questions regarding the project guidelines.

The team sponsor, Alex York of Beyond Innovation, lived out of town so communication with him was difficult at times. Due to limited availability of Alexander, issues arose with finding a proper time to conduct meetings over the phone. This problem was realized quickly and resolved through increased use of emails restructuring the schedule to allocate more time to speak with Alex. Along with weekly phone conferences, the team also met, in person, with Alex once a month. During then, the team could update him, in more detail, about the progress of the project. They

could also show him design prototypes and get his advice on the project. Once consistent communication with the sponsor was established, the progress of the design became much more fluent as the team were able on specific goals that the sponsor wanted accomplished.

7. Conclusion

With abundant information from last year's project, and with a team member who had direct involvement in its development, the Senior Design project benefited greatly from the past experiences. By the end of the first half of the project, the team accomplished the three objectives stated initially: the structural elements and the translating mechanism were modeled in 3D, the materials for the stowing arms were selected, and long-lead items were procured. To reduce risk of injury and assembly failure, the mechanics subsystem was designed for the structural elements to provide vertical and lateral support for the slate, accounting for scenarios where the table is incorrectly rotated to an upside-down position.

The second half of the project consisted of some minor but important design changes, with a heavy emphasis on fabrication and testing. In consideration of the user safety concerns brought up by classmates, the housing system was replaced with a very practical removable-dolly setup. As soon as the dolly idea came up, the team developed the necessary CAD models to simulate the load onto the dollies. The milestone reached by the simulation opened the door for finalizing the details that had been left out before, such as the mechanisms that would lock the table in place and addressing the load created by the table on household tile. This paper presented the benefits of this stowing method, along with a detailed explanation of the functional aspects of it.

Since the beginning of the Spring semester, the electronic subsystem has been thoroughly tested every time a new component was integrated. The power requirements were underestimated but since it was discovered with sufficient time remaining it was addressed and was brought under control. The final product, with its functionality, robustness, excellent aesthetic value, and its documentation, is a great reflection of the time and efforts that were put into building a product that meets all 6 objectives pushed for in the beginning of the project.

References

- [1] Gross, Norman, and Alexander York. "Deliverables 2014 Final Report." *2013/2014 Senior Design Team19*. Beyond Innovation, LLC, n.d. Web. 26 Sept. 2014. <http://eng.fsu.edu/me/senior_design/2014/team19/deliverable.html>.
- [2] "World Pool-Billiard Association Tournament Table & Equipment Specifications." *World Pool-Billiard Association Tournament Table & Equipment Specifications*. Web. 10 Apr. 2015. <http://www.wpa-pool.com/web/WPA_Tournament_Table_Equipment_Specifications>.
- [3] Vescia, Paolo. "Velodyne Inventor Builds Self-leveling Boats." *Widgets RSS*. San Francisco Business Times, 15 Apr. 2014. Web. 26 Sept. 2014. <<http://www.bizjournals.com/sanfrancisco/gallery/22511>>.
- [4] Alvi, Dr. F. S. "Thermal Fluids Lab - Uncertainty Analysis." Web. 10 Apr. 2015. <http://www.eng.fsu.edu/~alvi/eml4304/webpage/uncertaintyanalysis_lectureComplete.pdf>.
- [5] "Orangutan X2 with VNH2 and LCD - Resource Database." Pololu. Web. 10 Apr. 2015. <<https://www.pololu.com/product/738/resources>>.

Appendix A: Dimensioned Drawings

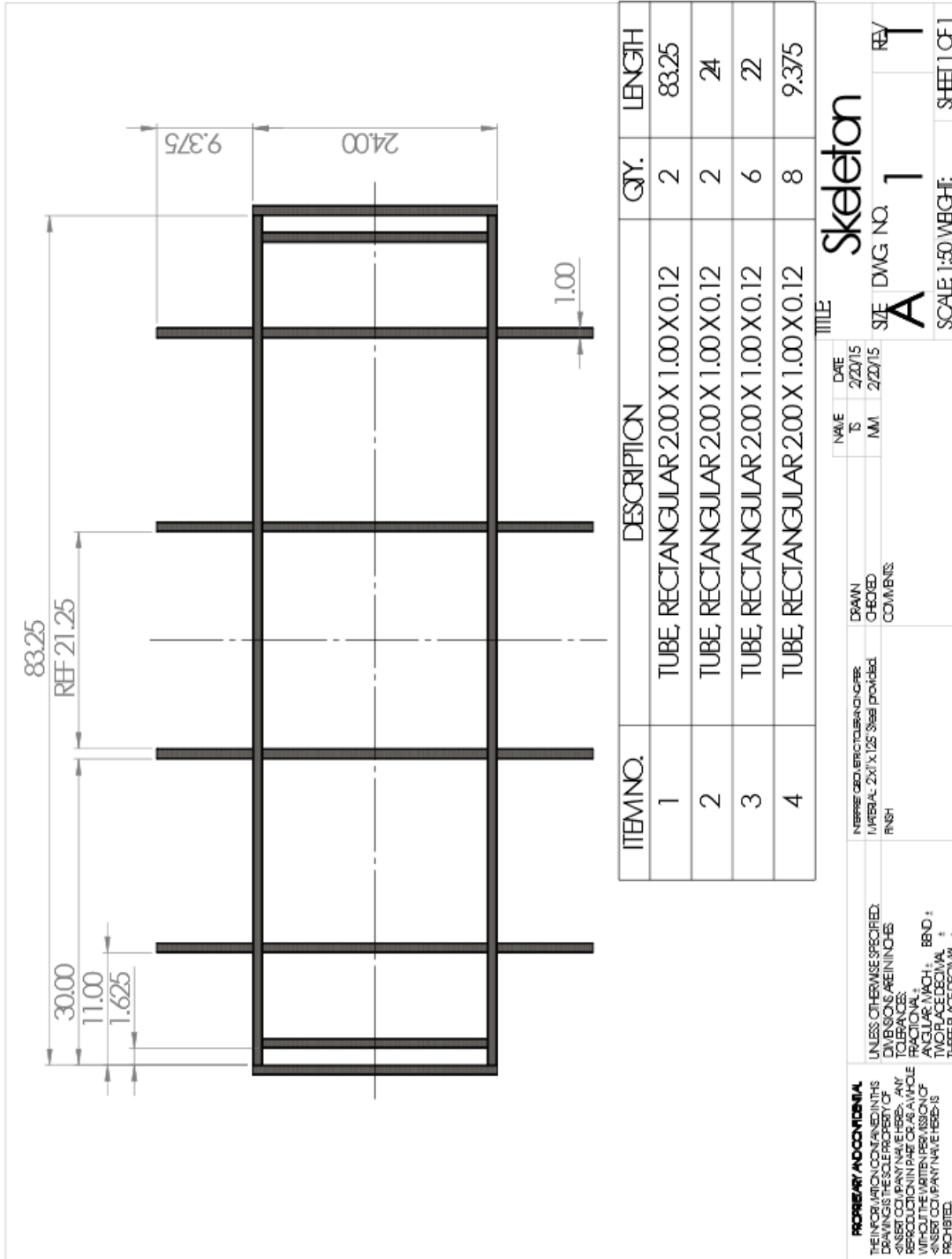

Quantity: 8

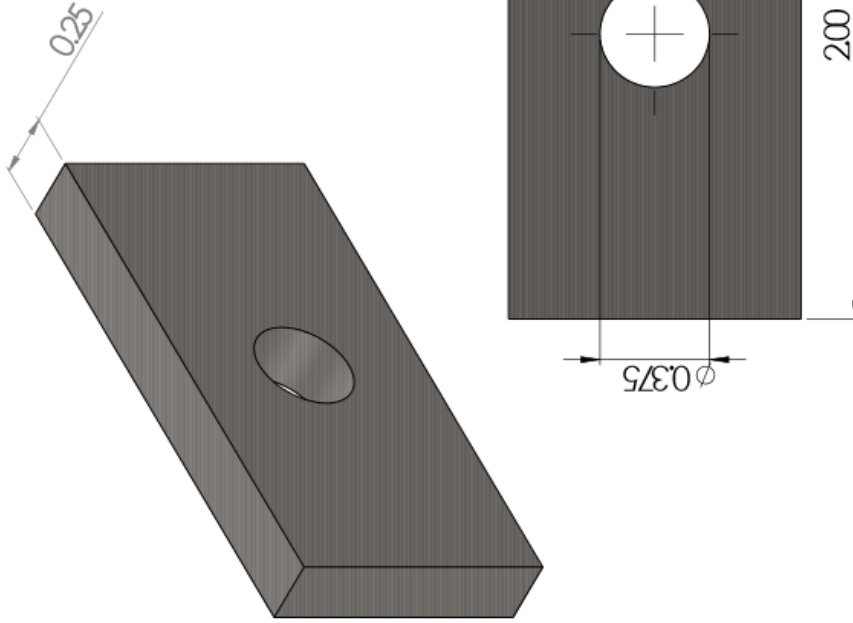

PROPRIETARY AND CONFIDENTIAL THE INFORMATION CONTAINED IN THIS DRAWING IS THE SOLE PROPERTY OF HEBBEY. IT IS NOT TO BE REPRODUCED OR TRANSMITTED IN ANY FORM OR BY ANY MEANS, WITHOUT THE WRITTEN PERMISSION OF HEBBEY. HEBBEY AND HEBBEY'S LOGO ARE TRADEMARKS OF HEBBEY. HEBBEY'S LOGO IS A REGISTERED TRADEMARK OF HEBBEY. HEBBEY'S LOGO IS A REGISTERED TRADEMARK OF HEBBEY. HEBBEY'S LOGO IS A REGISTERED TRADEMARK OF HEBBEY.	UNLESS OTHERWISE SPECIFIED: DIMENSIONS ARE IN INCHES DECIMALS ARE TO TWO FRACTIONS TO THE NEAREST SIXTEENTH INCH. BEND : TWO FACE DECIMAL : THREE FACE DECIMAL :	INTERPRET GEOMETRIC TOLERANCING PER: MATERIAL: 24X17X.25 Flat steel provided FINISH	DRAWN CHECKED COMMENTS	NAME TS	DATE 2/27/15	TITLE EndPlate
	SIZE A	DWG. NO. 2	REV 0	SCALE: 1:1 WEIGHT:	SHEET 1 OF 1	

Quantity: 18

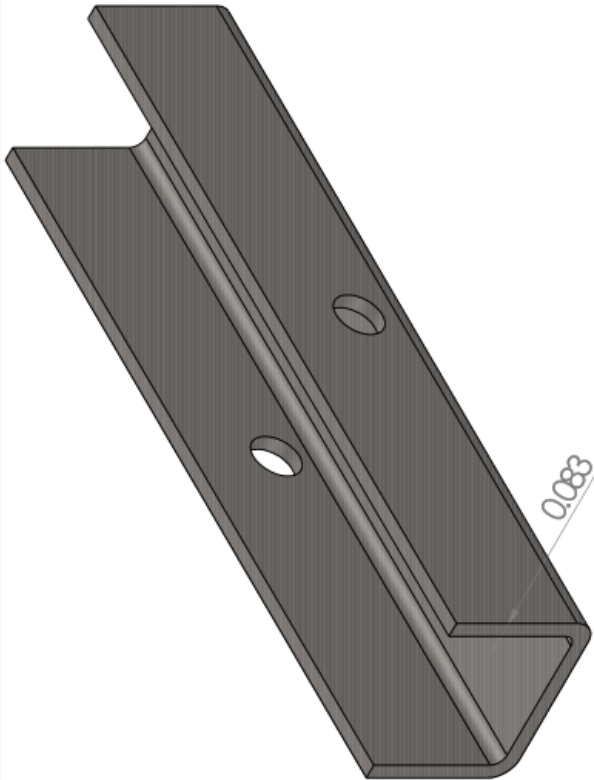

$\phi 0.257$

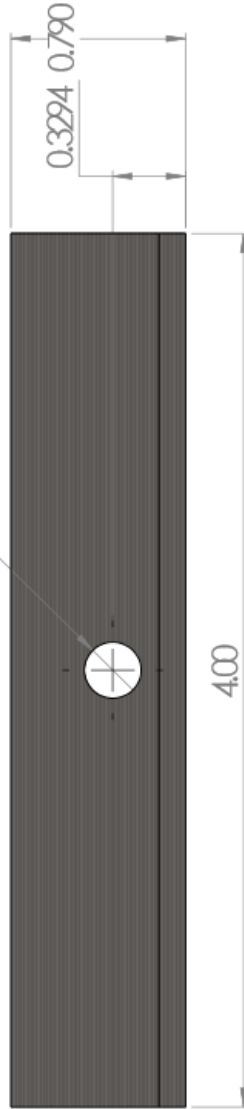

PROPRIETARY AND CONFIDENTIAL THE INFORMATION CONTAINED IN THIS DRAWING IS THE SOLE PROPERTY OF KINSSET COMPANY NAME HERE. ANY REPRODUCTION IN PART OR AS A WHOLE WITHOUT THE WRITTEN PERMISSION OF KINSSET COMPANY NAME HERE IS PROHIBITED.	UNLESS OTHERWISE SPECIFIED: DIMENSIONS ARE IN INCHES TOLERANCES: FRACTIONAL: ± 0.005 DECIMAL: ± 0.005 ANGULAR: MACH. ± 0.05 BEND: ± 0.05 TWO PLACE DECIMAL: ± 0.05 THREE PLACE DECIMAL: ± 0.005	INTERSET GEOMETRIC TOLERANCES PER: MATERIAL: 13X10X088 Steel Using provided FINISH	DRAWN: [blank] CHECKED: [blank] COMMENTS: Please add small chamfer in one direction of both holes for a 1/4-20 bolt to be in, maintaining tight fit.	NAME: TS DATE: 2/20/15	TITLE: Uchannel
	SIZE: A DWG. NO.: 3 SCALE: 1:2 WEIGHT: [blank]	REV: 0 SHEET 1 OF 1			

Quantity: 4

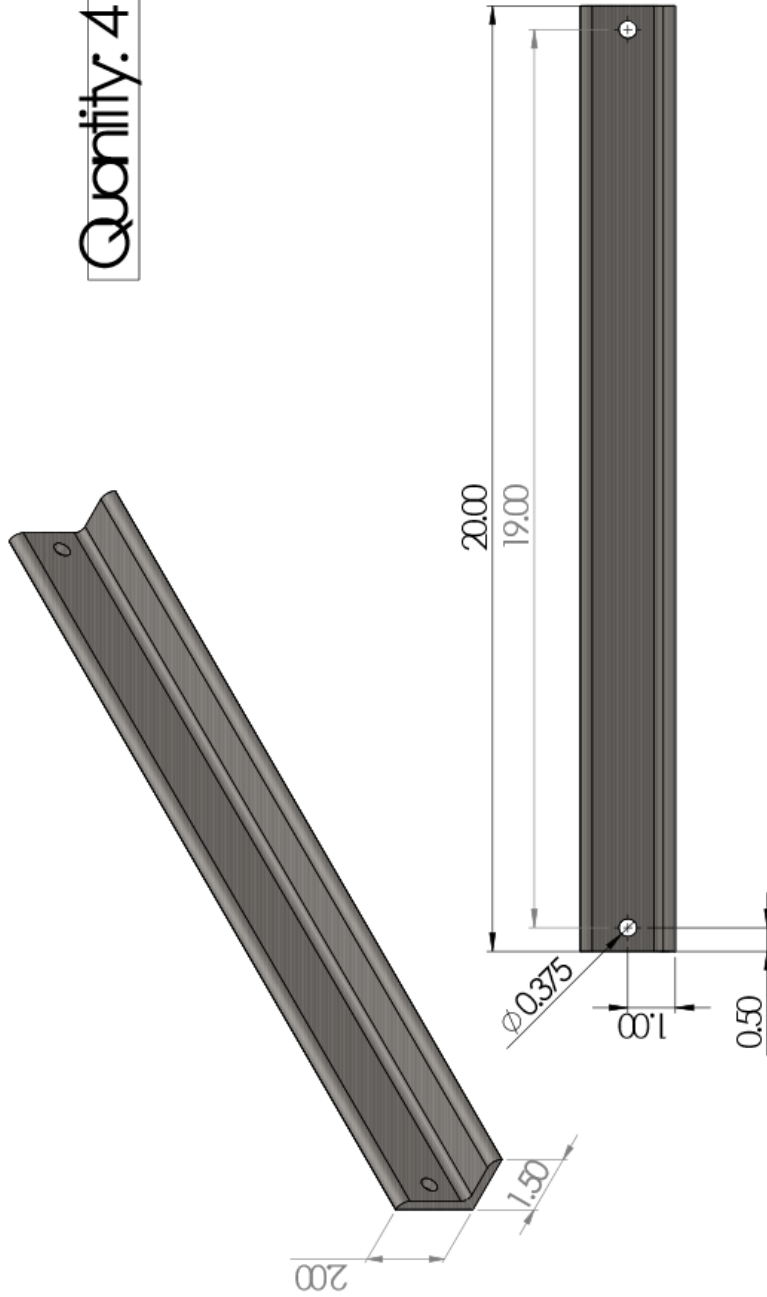

PROPRIETARY AND CONFIDENTIAL THE INFORMATION CONTAINED IN THIS DRAWING IS THE SOLE PROPERTY OF 4INSERT COMPANY NAME HERE. ANY REPRODUCTION IN PART OR AS A WHOLE WITHOUT THE WRITTEN PERMISSION OF 4INSERT COMPANY NAME HERE IS PROHIBITED.		INTERMET GEOMETRIC TOLERANCING PER: MATERIAL: 2X1.5X0.25 Steel Angle provided. FINISH:	DRAWN: CHECKED: COMMENTS:	NAME: TS DATE: 2/21/15	TITLE: Main Angel Iron
UNLESS OTHERWISE SPECIFIED: DIMENSIONS ARE IN INCHES. TOLERANCES: FRACTIONAL: ANGULAR: MACH: BEND: TWO PLACE DECIMAL; THREE PLACE DECIMAL;				SIZE: A DWG. NO.: 4 REV: 0	SCALE: 1:5 WEIGHT: SHEET 1 OF 1

Quantity: 4

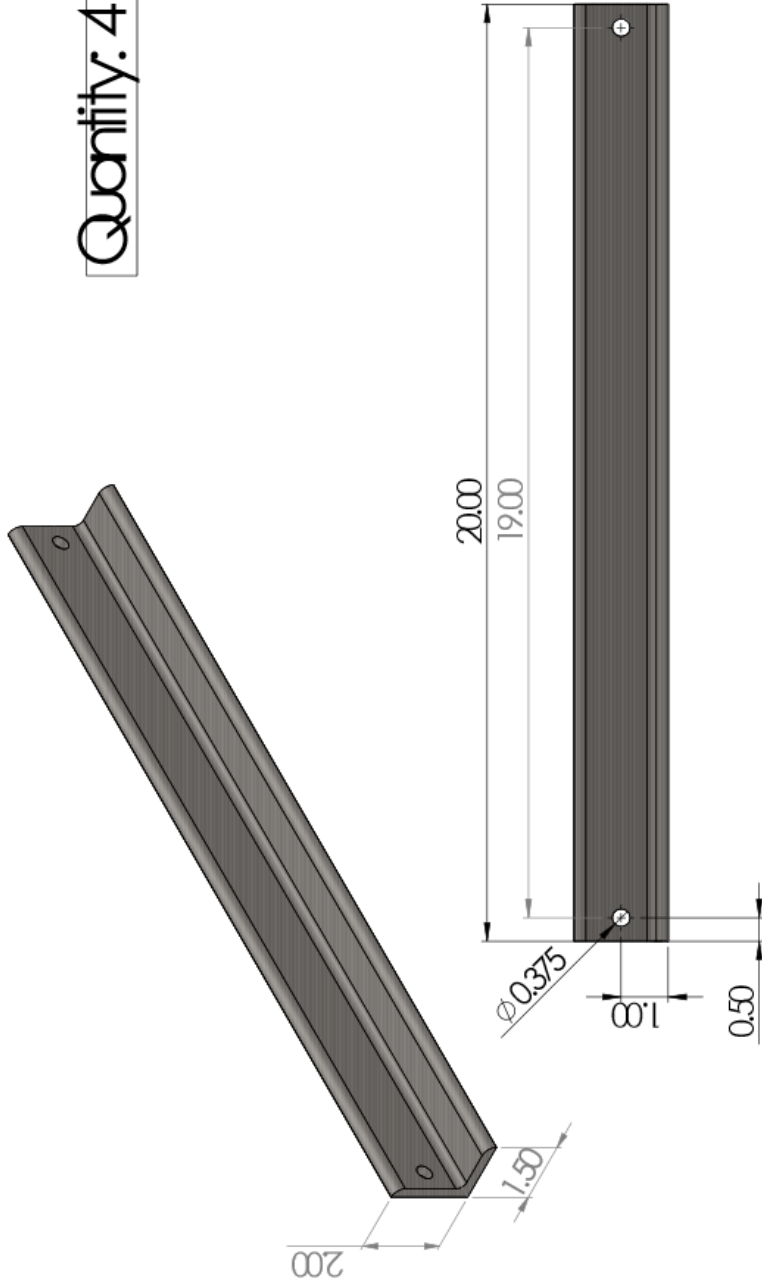

PROPRIETARY AND CONFIDENTIAL THE INFORMATION CONTAINED IN THIS DRAWING IS THE SOLE PROPERTY OF WINSSET COMPANY. ANY REPRODUCTION OR TRANSMISSION OF THIS DRAWING WITHOUT THE WRITTEN PERMISSION OF WINSSET COMPANY IS PROHIBITED.		UNLESS OTHERWISE SPECIFIED: DIMENSIONS ARE IN INCHES. TOLERANCES: FRACTIONAL: ANGULAR: MACH. BEND: THREE PLACE DECIMAL.		INBIBET GEO. DIRECTOR/BRANON: PFE: MATERIAL: 2X1.5X0.25" S188 Angle provided. FINISH:		DRAWN: CHECKED: COMMENTS:		NAME: TS	DATE: 2/27/15		
TITLE: Main Angle Iron		SIZE: A		DWG. NO.: 4		REV: 0		SCALE: 1:5		WEIGHT:	SHEET 1 OF 1

Quantity: 2

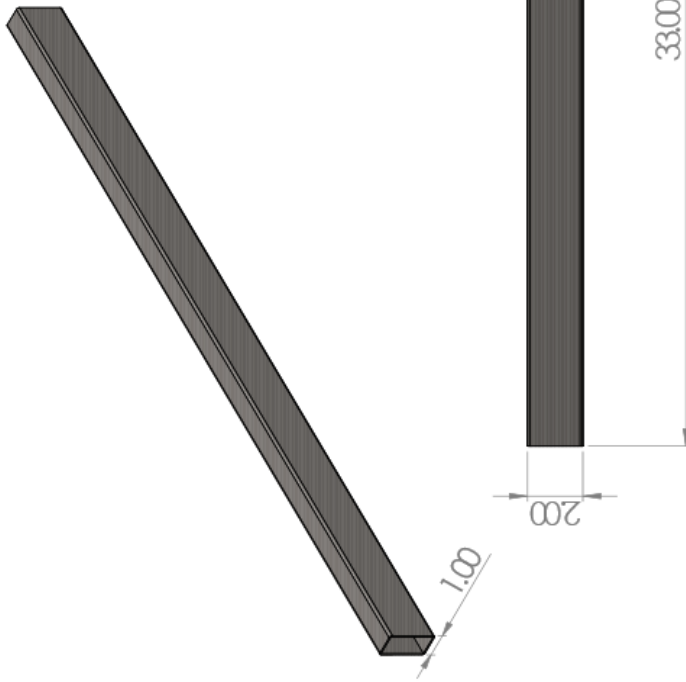

PROPRIETARY AND CONFIDENTIAL THE INFORMATION CONTAINED IN THIS DRAWING IS THE SOLE PROPERTY OF 4INSTEEL COMPANY. ANY REPRODUCTION IN PART OR AS A WHOLE WITHOUT THE WRITTEN PERMISSION OF 4INSTEEL COMPANY IS PROHIBITED.	UNLESS OTHERWISE SPECIFIED, DIMENSIONS ARE IN INCHES. FRACTIONAL DIMENSIONS SHALL BE TO NEAREST 1/16". DECIMAL DIMENSIONS SHALL BE TO NEAREST 0.001".	FINISH RUSH	NUMBER OF DIMENSIONS: 3 MATERIAL: 2X1X.065 Steel COMMENTS:	NAME: TS	DATE: 2/21/15	TITLE: EndSteel
				SIZE: A	DWG. NO.: 6	REV: 0
SCALE: 1:10 WEIGHT:				SHEET 1 OF 1		

Quantity: 18

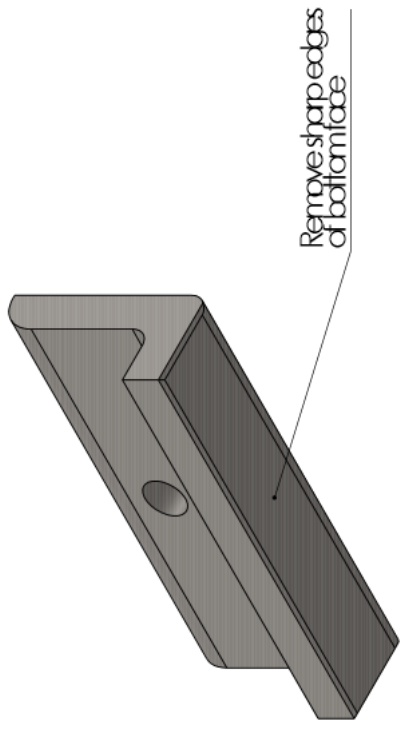
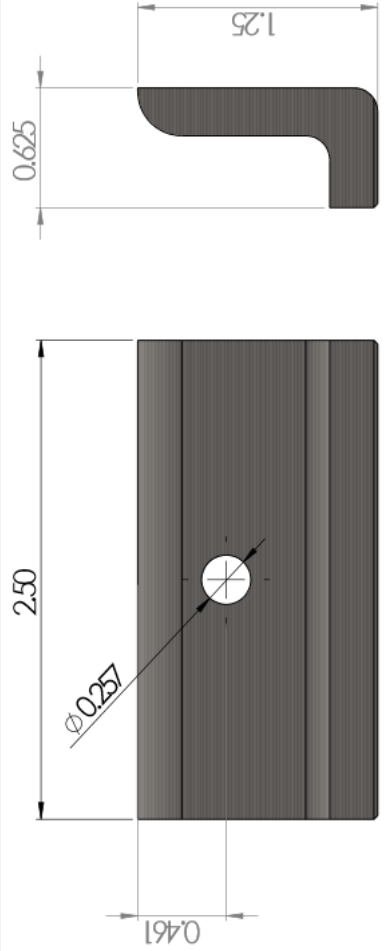

PROPRIETY AND CONFIDENTIAL THE INFORMATION CONTAINED IN THIS DRAWING IS THE SOLE PROPERTY OF INSERT COMPANY NAME HERE. ANY REPRODUCTION IN PART OR AS A WHOLE WITHOUT THE WRITTEN PERMISSION OF INSERT COMPANY NAME HERE IS PROHIBITED.	UNLESS OTHERWISE SPECIFIED, DIMENSIONS ARE IN CHS.	MATERIAL: 1.25% 25% 25% 3% 861 FINISH	DRAWN: [] CHECKED: [] COMMENTS: []	NAME: [] TS: []	DATE: 2/21/15	TITLE: Secondary Angle Iron
	TOLERANCES: FRACTIONAL, ANGULAR, MACH., BOND, TWO PLACE DECIMAL, THREE PLACE DECIMAL	SIZE: A DWG. NO.: 7 SCALE: 1:1 WEIGHT: []	REV: 0 SHEET 1 OF 1			

Quantity: 4

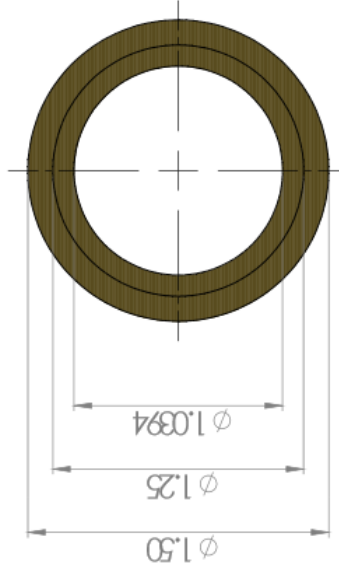
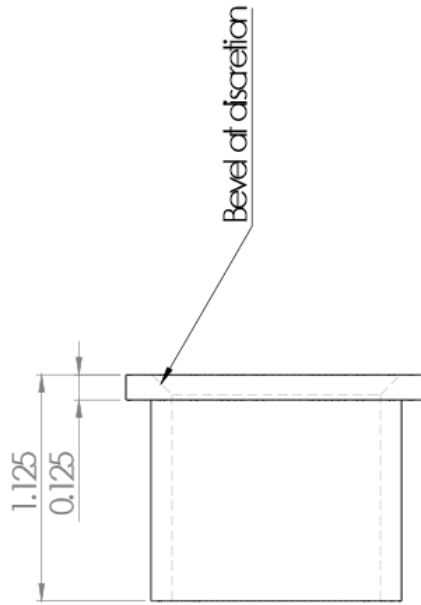
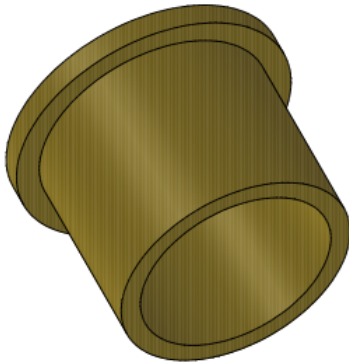

<p>PROPRIETARY AND CONFIDENTIAL</p> <p>THE INFORMATION CONTAINED IN THIS DRAWING IS THE PROPERTY OF HERSHEY COMPANY. ANY REPRODUCTION IN PART OR AS A WHOLE WITHOUT THE WRITTEN PERMISSION OF HERSHEY COMPANY IS PROHIBITED.</p>		<p>UNLESS OTHERWISE SPECIFIED: DIMENSIONS ARE IN INCHES FRACTIONS ANGULAR WATCH - BEND - TWO PLACE DECIMAL THREE PLACE DECIMAL</p>		<p>INSERT GEOMETRIC TOLERANCES PER MATERIAL SPECIFICATION FINISH</p>		<p>DRAWN CHECKED COMMENTS: This part is to be used as drawn except for bevel. The bevel may require no adjustment other than the bevel.</p>	<p>NAME TS</p>	<p>DRAWN 2/26/15</p>	<p>TITLE Main Brass Bushing</p>
						<p>SIZE DWG. NO. 8</p>		<p>REV 0</p>	
						<p>SCALE 1:1 WEIGHT:</p>		<p>SHEET 1 OF 1</p>	

Quantity: 4

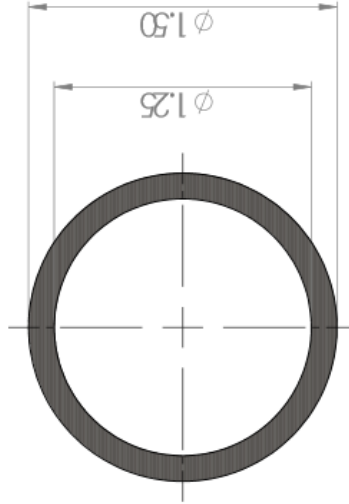
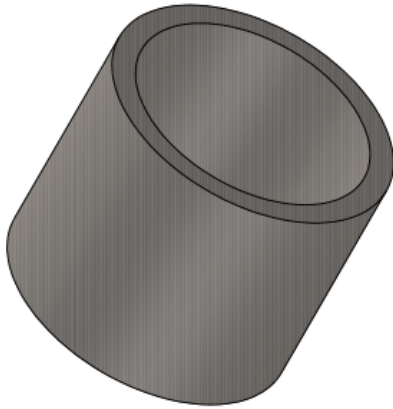

PROPRIETARY AND CONFIDENTIAL THE INFORMATION CONTAINED IN THIS DRAWING IS THE SOLE PROPERTY OF INSERT COMPANY NAME HERE. ANY REPRODUCTION IN PART OR AS A WHOLE WITHOUT THE WRITTEN PERMISSION OF INSERT COMPANY NAME HERE IS PROHIBITED.	UNLESS OTHERWISE SPECIFIED, DIMENSIONS ARE IN INCHES, FRACTIONAL ANGULAR MACH., BEND : TWO PLACE DECIMAL ; THREE PLACE DECIMAL ;	INTERPRET GEOMETRIC TOLERANCES PER: MATERIAL: 1.5" OD X 1.124" ID X 12 FREE TUBE FINISH	DRAWN: CHECKED: COMMENTS: Material is provided. Bushing of drawing #7 must be press fitted, please turn the ID accordingly.	NAME: TS DATE: 2/26/15	TITLE: Sleeve for main bushing
	SIZE: A DWG. NO. 9 REV. 0	SCALE: 1:1 WEIGHT: SHEET 1 OF 1			

Appendix B: Programming Flowchart

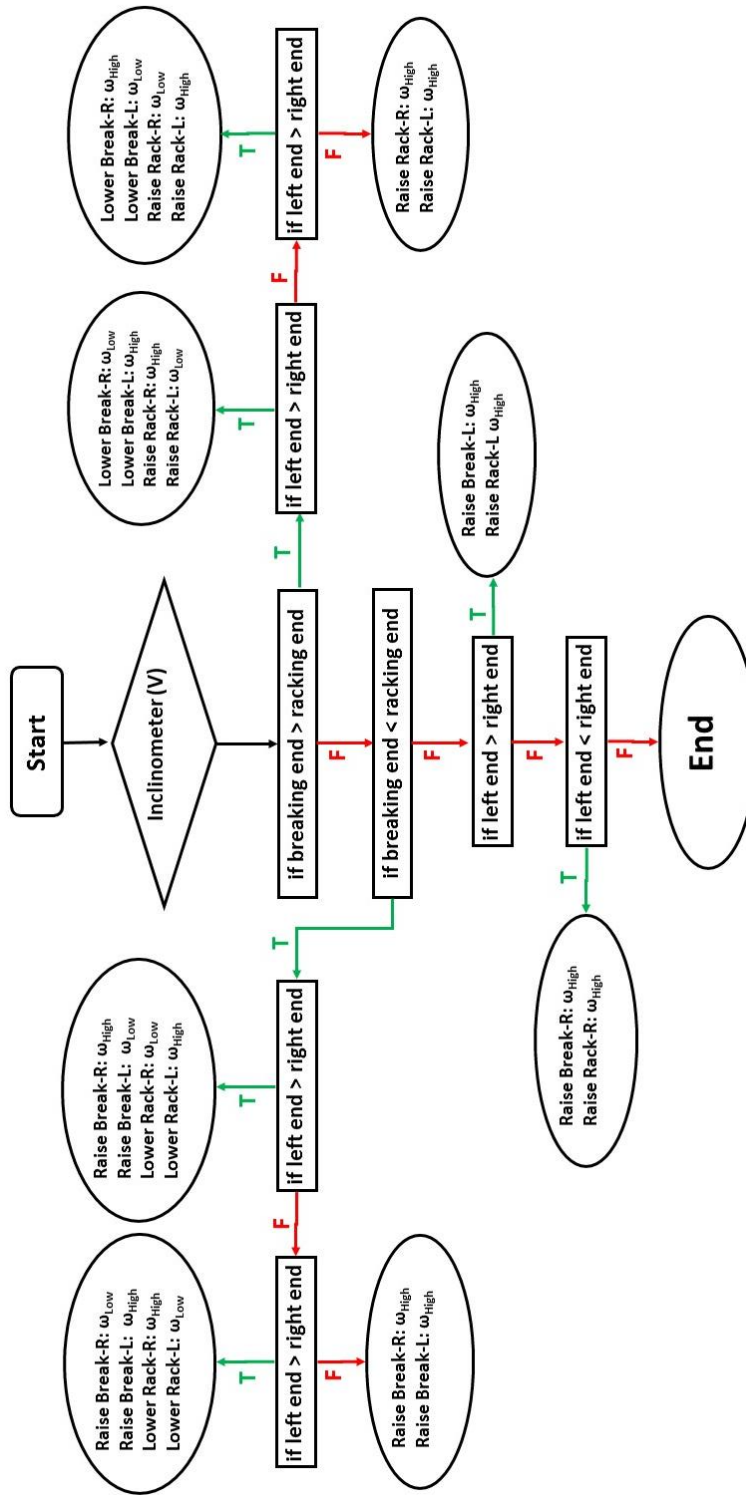

Appendix C: FMEA

Key Input	Failure Mode	Failure Effects	SEV	Potential Causes	OCC	Current Controls	DET	RPN	Actions Recommended	Responsible party	Action taken	Date
Dolly	Pin welds breaking	Collapse of table. Injury to user.	10	Improper material and geometry	6	None	10	600	Increase pin size	Silva	Increase weld area by inserting pin into the i-beam	2/15/2015
A												
Dolly	Pin welds breaking	Collapse of table. Injury to user.	10	Improper material and geometry	1	Testing of every dolly before delivery of product	2	20	None	DNA	DNA	Current
A'												
Slate	Not being able to fit a replacement slate as promised.	User tries to force fit and drops the slate.	5	High friction between angle irons and slate. Using uneven wood support.	2	CAD tolerances used to estimate fitment.	6	60	Make all angle irons removable	Manahan	As suggested.	1/20/2015
B												
Slate	Not being able to fit a replacement slate as promised.	User tries to force fit and drops the slate.	5	High friction between frame and slate. Using uneven wood support.	1	CAD tolerances used to estimate fitment.	2	10	None	DNA	DNA	Current
B'												
Woodwork	Uneven surfaces and poor fitment	Cost due to time spent reworking. Additional risk of power tool injuries.	7	Imperfect frame fabrication. Improper tools.	8	None	5	280	Obtain better tools like a table saw, or outsource wood work.	McHugh	Woodwork will be outsourced	3/30/2015
C												
Woodwork	Uneven surfaces and poor fitment	Cost due to time spent reworking.	7	Imperfect frame fabrication. Poor quality control.	3	Each piece is checked against the specific table it's going on.	5	105	Specify quality checks in contract with supplier.	Silva	As suggested.	4/2/2015
C'												

Appendix D: Gantt Chart

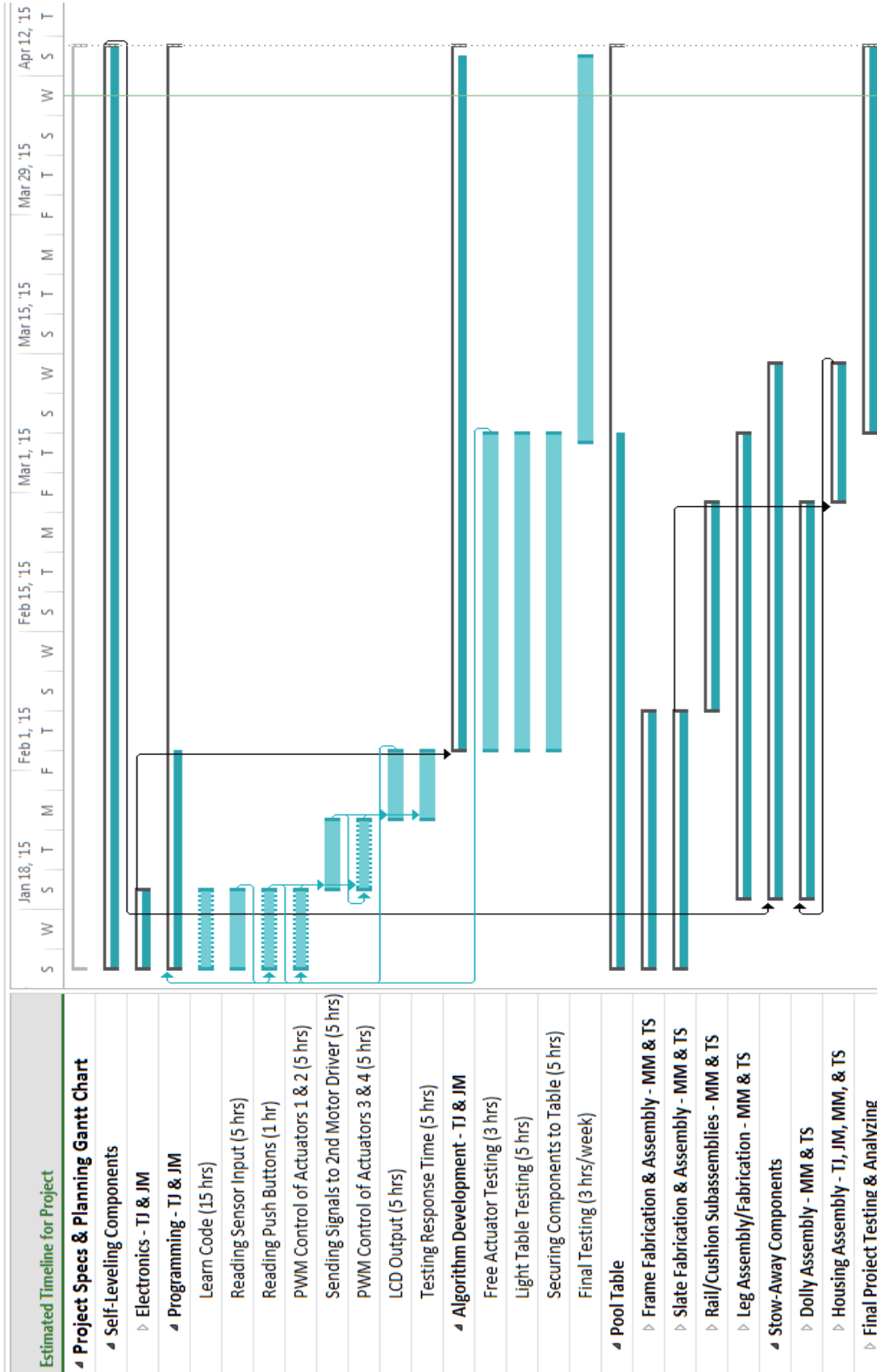

Appendix E: Bill of Materials

Team 6: Stow Away Pool Table Building Supplies Purchase Order									
Company	Order Date	Item	Part Number	Unit Cost	Quantity	Additional Costs	Total Cost	Source	Notes
Adafruit	11/30/2014	Hook-up Wire Spool Set - 22AWG Solid Core - 6 x 25 ft	1311	\$ 15.95	1	\$ -	\$ 15.95	http://www.adafruit.com/products/1311?cid=CjwKEA	N/A
Superbright LEDs	11/30/2014	16 AWG Four Conductor Power Wire	WP16-4	\$ 0.59	50	\$ -	\$ 29.50	https://www.superbrightleds.com/moreinfo/plugs-connectors-sockets/16-awg-four-conductor-power-wire/305/3275/	N/A
	11/30/2014	22-16 AWG Grey 3M Wire Nut	WN-2216	\$ 0.09	50	\$ -	\$ 4.50	https://www.superbrightleds.com/moreinfo/installation-supplies/22-16-awg-grey-3m-wire-nut/663/1724/	N/A
Robot Shop	11/30/2014	Sharp GP2Y0A02YK0F IR Range Sensor - 20 cm to 150 cm	RB-Dem-02	\$ 14.59	1	\$ -	\$ 14.59	http://www.robotshop.com/en/sharp-gp2y0a02y0f-ir-range-sensor.html	N/A
eBay: intl-trading	11/30/2014	Heavy Duty 6" 330lbs Pound Max Lift 12Volt DC Linear Actuator&Mounting Brackets	N/A	\$ 65.54	4	\$ -	\$ 262.16	http://www.ebay.com/itm/Heavy-Duty-6-330lbs-Pound-Max-Lift-12Volt-DC-Linear-Actuator-Mounting-Brackets-/191403190817?ssPageName=STRK%3AMESEK3AIT	N/A
	2/5/2015	Heavy Duty 6" 330lbs Pound Max Lift 12Volt DC Linear Actuator&Mounting Brackets	N/A	\$ 65.54	2	\$ -	\$ 131.08	http://www.ebay.com/itm/Heavy-Duty-6-330lbs-Pound-Max-Lift-12Volt-DC-Linear-Actuator-Mounting-Brackets-/191403190817?ssPageName=STRK%3AMESEK3AIT	N/A
Muellers	12/4/2014	Replacement 7 Valley Coin-Op Rails Set of 6	36-237	\$ 149.95	1	\$ -	\$ 149.95	http://www.muellers.com/Replacement-7-Valley-Coin-Op-Rails-Set-of-6.html	N/A
Online Metals	12/4/2014	Mild Steel A513 Hot Rolled Rectangle Tube 1 1/2" x 0.12" Cut to: 24"	N/A	\$ 13.03	15	\$ 19.50	\$ 214.95	http://www.onlinemetals.com/merchant.cfm?pid=10125&step=4&showunits=inch&id=241&top_cat=849	N/A
	12/4/2014	Mild Steel A513 Hot Rolled Rectangle Tube 1 1/2" x 0.12" Cut to: 84"	N/A	\$ 34.21	2	\$ -	\$ 68.42	http://www.onlinemetals.com/merchant.cfm?pid=10125&step=4&showunits=inch&id=241&top_cat=849	N/A
	12/4/2014	Mild Steel A513 Hot Rolled Rectangle Tube 1 1/2" x 0.12" Cut to: 36"	N/A	\$ 27.00	6	\$ 6.00	\$ 168.00	http://www.onlinemetals.com/merchant.cfm?pid=10125&step=4&showunits=inch&id=241&top_cat=849	N/A
	12/4/2014	Mild Steel A569/ASTM A1011 Hot Rolled Sheet 0.125" (11ga.) Cut to: 12" x 12"	N/A	\$ 10.25	1	\$ -	\$ 10.25	http://www.onlinemetals.com/merchant.cfm?pid=10125&step=4&showunits=inch&id=241&top_cat=849	N/A
Metals Depot	12/4/2014	2" x 1-1/2" x 1/4" Steel Angle A-36 Steel Angle Size: 2 Ft.	A1211214	\$ 10.80	6	\$ -	\$ 64.80	http://www.metalsdepot.com/products/hrsteel2.phrtm?page=angle&LimAcc=%20&id=401038	N/A
	12/4/2014	1/4" x 1" Hot Rolled A-36 Steel Flat Size: 2 Ft.	F2141	\$ 2.84	2	\$ -	\$ 5.68	http://www.metalsdepot.com/products/hrsteel2.phrtm?page=flat&LimAcc=%20&id=401155	N/A
	12/4/2014	1" x 1" x 1/8" Steel Angle A-36 Steel Angle Size: 2 Ft.	A11118	\$ 2.64	6	\$ -	\$ 15.84	http://www.metalsdepot.com/products/hrsteel2.phrtm?page=angle&LimAcc=%20&id=401026	N/A
Lowes	12/4/2014	Klein-Brady Pexlon Board (Common: 1-in x 12-in x 48-in; Actual: 0.75-in x 11.25-in)	Item #: 1105 Model #: 0118	\$ 21.58	8	\$ -	\$ 172.64	http://www.lowes.com/pid/1105-9989-0118-0_20000143-34026108411-1105&url=1&currentURL=%3Ftrk%3D1105&facetinfo="	We can pick this order up from the store to avoid shipping costs.
Pololu	11/28/2014	Orangutan X2 Motor Controller	738	\$ 149.00	2	\$ -	\$ 298.00	http://www.pololu.com/product/738	N/A
	11/28/2014	Dual VNH2SP30 Motor Driver Carrier MDD3A	708	\$ 59.95	1	\$ -	\$ 59.95	http://www.pololu.com/product/708	N/A
	12/4/2014	Wall Power Adapter: 12VDC, 5A, 5.5x2.1mm Barrel Jack, Center-Positive	1468	\$ 18.95	1	\$ -	\$ 18.95	http://www.pololu.com/product/1468	N/A
	12/4/2014	Pololu SV_1A Step-Down Voltage Regulator D28V10E5	2831	\$ 7.49	2	\$ -	\$ 14.98	http://www.pololu.com/product/2831	N/A
	12/4/2014	DC Power Adapter Barrel Jack	1139	\$ 0.85	1	\$ -	\$ 0.85	http://www.pololu.com/product/1139	N/A
	12/4/2014	400-Point Breadboard	351	\$ 3.75	1	\$ -	\$ 3.75	http://www.pololu.com/product/351	N/A
	3/10/2015	Snap-Action Switch with 16.3mm Roller Lever - 3 Pin, SPDT, SA	1404	\$ 0.85	4	\$ -	\$ 3.40	https://www.pololu.com/product/1404	Paid for by Joel
	3/10/2015	ID 100 (1.54mm) Breakaway Wire Header: 2x40 Pin, Straight	966	\$ 1.95	1	\$ -	\$ 1.95	https://www.pololu.com/product/966	Paid for by Joel
	3/10/2015	Pololu 12V, 500mA Step-Down Voltage Regulator D24V5F12	2846	\$ 4.25	5	\$ -	\$ 21.25	https://www.pololu.com/product/2846	Paid for by Joel
	3/10/2015	PCB01A 5" Round Prototyping PCB	330	\$ 11.95	1	\$ 4.45	\$ 16.40	https://www.pololu.com/product/330	Paid for by Joel - \$8H for 3/10 order included in additional costs
	3/18/2015	Aluminum Standoff: 1/4" Length, 2-56 Thread, F-F (4-Pack)	2082	\$ 1.49	4	\$ -	\$ 5.96	https://www.pololu.com/product/2082	Paid for by Joel
	3/18/2015	Machine Hex Nut: #2-56 (25-pack)	1067	\$ 0.99	1	\$ -	\$ 0.99	https://www.pololu.com/product/1067	Paid for by Joel
	3/18/2015	Machine Screw: #2-56, 7/16" Length, Phillips (25-pack)	1957	\$ 0.99	1	\$ -	\$ 0.99	https://www.pololu.com/product/1957	Paid for by Joel
	3/18/2015	Orangutan X2 with VNH2	718	\$ 119.00	1	\$ -	\$ 119.00	https://www.pololu.com/product/718	Paid for by Joel
	3/18/2015	16-Conductor Ribbon Cable with IDC Connectors 30"	973	\$ 3.49	1	\$ -	\$ 3.49	https://www.pololu.com/product/973	Paid for by Joel
	3/18/2015	Adafruit Perma-Proto Half-Size Breadboard	2766	\$ 12.50	1	\$ -	\$ 12.50	https://www.pololu.com/product/2766	Paid for by Joel
	3/18/2015	Machine Screw: M3, 25mm Length, Phillips	1077	\$ 1.75	1	\$ -	\$ 1.75	https://www.pololu.com/product/1077	Paid for by Joel
	3/18/2015	Machine Hex Nut: M3 (25-pack)	1069	\$ 0.99	1	\$ 9.95	\$ 10.94	https://www.pololu.com/product/1069	Paid for by Joel - \$8H for 3/18 order included in additional costs
Speedy Metals	2/16/2015	1" SQ (A) x 0.834" ID (B) x .083" Wall (C) Square Steel Tubing-24"	SKU: ts1x.083-24	\$ 3.98	4	\$ -	\$ 15.92	https://www.speedymetals.com/p-4782-1-x-0083-x-1-wall-square-steel-tubing.aspx	U Channel
	2/16/2015	1" SQ (A) x 0.760" ID (B) x .120" Wall (C) Square Steel Tubing-24"	SKU: ts1x.120-24	\$ 5.36	17	\$ -	\$ 91.12	http://www.speedymetals.com/p-4783-8251-1-x-012-x-1-wall-square-steel-tubing.aspx	Leg Frames
	2/16/2015	1/4" (A) x 1-1/4" (B) x 1-1/4" (C) Angle, A-36 Hot Rolled Steel [24"]	A111444	\$ 6.32	3	\$ -	\$ 18.96	https://www.speedymetals.com/p-3943-8210-1-14-x-1-14-x-1-14-angle-a-36-1000-hot-rolled-steel.aspx	Angle bars for Rail Support/Assembly
	2/16/2015	1" (A) x 2" (B) x .120" Wall (C) Rectangular Steel Tube-36"	SKU: tr1x2x.120-36"	\$ 12.99	9	\$ -	\$ 116.91	https://www.speedymetals.com/p-4699-8224-2-x-1-x-120-wall-rectangular-steel-tubing.aspx	2x1 for lateral support for short ends, plus extra for main frame, plus diagonals
	2/16/2015	1" (A) x 2" (B) x .065" Wall (C) Rectangular Steel Tube-36"	SKU: tr1x2x.065-36"	\$ 7.67	3	\$ -	\$ 23.01	https://www.speedymetals.com/p-4698-8224-2-x-1-x-065-wall-rectangular-steel-tubing.aspx	2x1 for lateral support for long ends
	2/16/2015	1/4" A-36 Hot Rolled Steel Plate-12" x 12" Plate	SKU: hp.25-12x12	\$ 14.66	5	\$ 5.00	\$ 78.30	https://www.speedymetals.com/p-4190-8221-14-a-36-hot-rolled-steel-plate.aspx	Plates for legs
	2/16/2015	1-1/2" OD (A) x 1.124" ID (B) x .188" Wall (C) DOM Steel Tube-12"	SKU: dom1.5x.188-12"	\$ 10.17	1	\$ -	\$ 10.17	https://www.speedymetals.com/p-3467-8242-1-12-od-x-188-wall-dom-steel-tube.aspx	Bushing Sleeve
2/16/2015	1-1/2" (A) Rd A-36 Hot Rolled Steel-12"	SKU: hr1.5-12"	\$ 9.26	1	\$ -	\$ 9.26	https://www.speedymetals.com/p-4232-8237-1-12-rd-a-36-1000-hot-rolled-steel.aspx	Leg/Foot Adapter	
McMaster-CARR	2/16/2015	Zinc-Plated Steel Weld-in Pull Pin Nonlocking with T-Handle, 1/2" Pin Diameter, 1-1/2" Barrel L	90222A116	\$ 9.31	6	\$ -	\$ 55.86	http://www.mcmaster.com/890222a116/vwxp956	Locking Pins
	2/16/2015	Food Grade SAE 841 Bronze Flanged Sleeve Bearing for 1" Shaft Diameter, 1-1/4" OD, 1" Length	3746K32	\$ 6.04	5	\$ -	\$ 30.20	http://www.mcmaster.com/83746k32/vwzofat	Bushing
AllPool.net	1/14/2015	Championship 4066 Invitational Teflon Cloth - 7' Pool (bed cloth & 6 rail cloths); Euro Blue	N/A	\$ 93.00	1	\$ -	\$ 93.00	https://www.pooltablefeltdo.com/championship-billiards/product/invitational-teflon-4066.html	N/A
Polycase	2/23/2015	DC-58F DC Series Heavy Duty Electronics Enclosure	DC-58F	\$ 11.99	1	\$ -	\$ 11.99	http://www.polycase.com/dc-58f	Housing for electronics
	2/23/2015	DC-58K DC Series Mounting Panels	DC-58K	\$ 9.55	1	\$ -	\$ 9.55	http://www.polycase.com/dc-58k	Housing for electronics
The Turtle Lab	2/16/2015	AT-AT Feet 5" Diameter Foot - Set of 4	N/A	\$ 25.00	4	\$ -	\$ 100.00	http://theturtlelab.com/product/feet-5-diameter-foot/	Free shipping
Total Cost (Before Shipping & Handling Fees)							\$2,587.60		

Biography

Thomas Silva was captain for the Baja team for ASME. This leadership experience along with the technical knowledge of the Mechanical Engineering coursework allowed him to intern at Dan Foss Turbocor Compressors. Upon graduation, Thomas would like to work in the Defense industry.

Joel Manahan has had experience with prototype development on his own and hopes to continue to innovate and bring to market smart new products. Joel would like to further relationships with manufacturers to bring his own inventions to fruition but is also willing to gain experience working for innovative companies as a mechanical design engineer.

Matthew McHugh is a perfectionist, always concerned with the way things look. Whether it's the formatting of his work or the products that he is designing and developing. He strives for perfection and his experience working at Owens Corning taught him to always put safety first.

Travis Jarboe draws from his experience at the Fitness and Movement clinic at FSU as the Student Director of Finance and Accounting. He is interested in mechanical engineering design and is going to enter the Management Trainee Program at Norfolk Southern after graduation.