



## **FAMU/FSU College of Engineering**

### **Department of Mechanical Engineering**

### **Concept Development**

#### ***Team 10 Autonomous ATV***

##### *Group Members:*

Michael Brazeau	Marc Akbar	Jeremy Hammond
Omesh Dalchand	Lester Kendrick	Merrick Salisbury

##### *Sponsors:*

Center for Intelligent Systems, Control, and Robotics (CISCOR)

##### *Advisors:*

Dr. Chiang Shih	Dr. Kamal Amin
Dr. Oscar Chuy	Dr. Emmanuel Collins

##### *Instructor:*

Dr. Kamal Amin

**10/25/2013**

# Table of Contents

<i>Abstract/Summary</i> .....	2
<i>Project Overview</i> .....	2-3
<i>Design and Analysis</i> .....	4-24
<i>Function Analysis</i> .....	4-6
<i>Design Concepts</i> .....	7-24
<i>Lasers</i> .....	7-10
<i>Encoders</i> .....	11-15
<i>Steering Motor</i> .....	16-17
<i>GPS</i> .....	17-19
<i>Heat Dissipation</i> .....	19-22
<i>IMU</i> .....	22-24
<i>Programming needs and Control</i> .....	25-31
<i>Conclusion</i> .....	32
<i>Future Work</i> .....	32
<i>Gantt Chart</i> .....	33
<i>References</i> .....	34
<i>Appendix</i> .....	35-40

## Abstract/Summary

This midterm report will illustrate and explain all of the conceptual designs required reach the end goal of creating a fully functional autonomous ATV. The scope of this project is very large. It ranges from mounting up to ten sensors, powering those sensors and making the sensors communicate with onboard computers. There will also be C++ code development of autonomous algorithms. This project will span the fields of mechanical engineering, fluid dynamics, computer/software engineering and electrical engineering.

## Project Overview

- *Problem Statement:*

CISCOR currently has multiple robotic platforms used in research ranging from bio-inspired legged walking robots to four wheel skid-steered robots. Some of these platforms are able to function outside on limited terrain types. This induces a need for a vehicle that is able to traverse many types of difficult terrains. Thus, the ATV was a clear choice for a platform to automate. Last year, actuators were installed onto the controls of the ATV. The task this year is to incorporate sensing and computer systems to interface with these actuators and develop algorithms for autonomous motion.

- *Justification/Background:*

Research into autonomous ground vehicles is growing rapidly. There is a need for vehicles to perform tasks without any physical interaction or human control. These tasks can range from dangerous search and rescue missions to civilian vehicles driving themselves through city streets. CISCOR is currently conducting research with autonomous mobile robots with emphasis on path planning and efficiency. This same type of research is desired with a more robust system that can handle difficult terrains and obstacles, as well as normal driving situations on a paved surface. For this reason, an ATV was chosen as the new platform to develop autonomous control.

- *Objective:*

The main objective is to integrate a sensory system that will scan the surrounding environment. This data is then used to compute a trajectory for the ATV to perform waypoint navigation and road following autonomously. These sensors include Encoders, SICK laser sensors, IMU (Inertial Measurement Unit), GPS system for waypoint navigation, and possibly a stereoscopic camera. Problems including the overheating of the motor-drivers and an underpowered steering actuator will also be resolved. Waterproofing the sensors, encoders and actuators must also be done to ensure all-terrain capabilities. To assist with safety, a way to shut down the ATV remotely will be developed. A kinematic model of the system will also be developed to implement the autonomous control. All of the objectives will be finished by April 2014

- *Constraints:*

There is a budget of approximately 1500.00 USD set aside for building material. Most of the sensors and computers are already purchased. A large hurdle to overcome will be scheduling time for all team members to work on the project at specific times. Each student has a separate and unique schedule that needs to be taken into account. The largest constraint on this project will be time. There are many objectives to complete and all of them must be met by the end of April 2014.

## Design and Analysis

- *Functional analysis:*

The following is a list of all components and the electrical/mechanical specifications of each component.

- **Toughbook Laptop Computer**

The project will incorporate 3 of these laptops. One will be running Ubuntu and ROS and receiving sensory data from all of the sensors with exception of the encoders. This computer will then process the sensory data and output a trajectory to the next onboard laptop. The other laptop will also be onboard the ATV and will be running QNX operating system. This laptop will receive sensory data from all of the encoders and send output signals to all of the actuators. The third Laptop will be used as a “chase” computer, allowing the users to monitor the system through a wireless connection with a router onboard the ATV. The laptops come with an Intel i5 processor and 4GB of RAM.

- **SICK LMS 200 Laser Distance Measurement system**

The project will incorporate 2 of these distance sensors. One will be mounted in such a way that it can view 5 feet directly in front of the vehicle and the other sensor will be mounted to view about 20 feet in front of the vehicle. The laser can scan 180 degrees with an angular resolution of 0.25 degrees. This yields 720 data points per laser pass. It has a maximum range of 80 meters with a resolution of 1 centimeter and an error of  $\pm 4.0$  centimeters. The laser communicates via serial (RS232) and outputs the distances measured in centimeters [cm]. Supply voltage is 24VDC and draws a continuous current of 1.8 A. Figure 1 shows how the laser scans surrounding objects. All mechanical dimensions can be found in Appendix A-1.

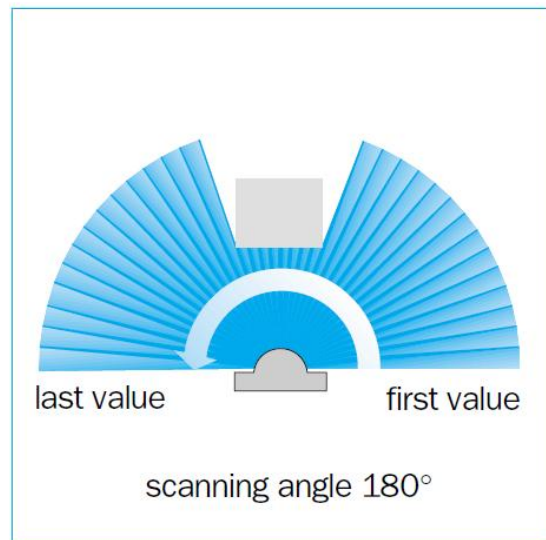

Figure 1. SICK LMS 200 scanning profile

- **Accu-Coder model 725 Encoder**

The ATV will use 4 encoders, one on each wheel to keep track of its position. The encoder when run in quadrature will output 30,000 counts per revolution. This is done by 2 IR sensors inside the encoder that are 180 degrees out of phase. This gives quadruple the resolution using the same sensor wheel and also gives the option to sense the direction of rotation using a few lines of code. The output of the encoder can be seen in Figure 2. The supply voltage is 4.75 – 28 VDC. Max shaft speed is 8000 RPM with a max frequency of 1 MHz. The mechanical dimensions and specifications can be found in Appendix B-1.

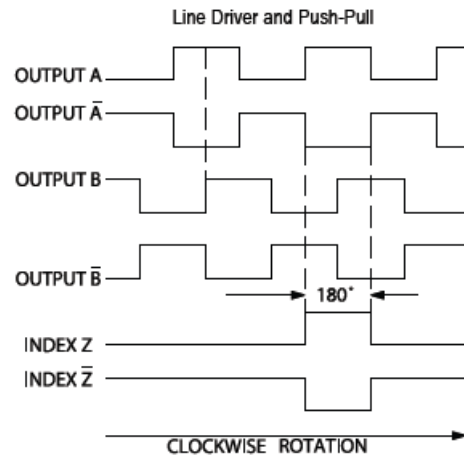

Figure 2. Accu-coder model 725 data output

- **Crossbow Inertial Measurement Unit (IMU)**

The linear accelerations on all 3 spatial dimensions must be known to be able to control the ATV in between GPS signals and also to detect possible vehicle rollover. The IMU is a 6 degree of freedom sensor that utilizes solid state accelerometers and MEMS gyroscopic sensors to measure angular rate of rotation along the 3 spatial dimensions as shown in Figure 3.

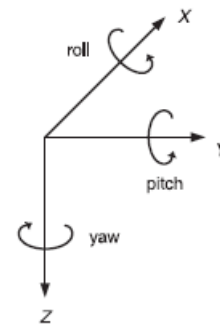

Figure 3. 3 dimensional coordinate axes with 6 DOF



Figure 4. Crossbow Inertial Measurement Unit

Supply voltage is 9-30 VDC and consumes energy at a rate of 3 W. It can measure an angular velocity of  $\pm 100$  degrees/sec with a resolution of 0.025 degrees/sec. The IMU can measure linear accelerations of  $\pm 2g$  with a resolution of less than 0.001g. Communication protocol is RS232. All mechanical dimensions and specifications can be found in Appendix C-1.

- **NovAtel ProPak-G2plus GPS**

For waypoint to waypoint autonomous navigation a GPS system is needed to locate the ATV on the face of the earth with precise coordinates. The ProPak-G2 can give position accuracy within a 1.8 meter diameter circle. Supply voltage is 9 to 18 VDC and consumes energy at a rate of 2.5 W. Communication is serial (RS232)



Figure 5. NovAtel ProPak-G2plus GPS receiver

or optional USB. Data output rate is 20 Hz and may take up to 50 seconds to get the first location fix. To receive the GPS signals from the satellites a Precise Positioning Management (PPM) L1 passive antenna will be installed. All mechanical dimensions and electrical specifications can be found in Appendix D-1.

- **Maxon RE50 Graphite Brushed DC motor / GP 62 planetary gearhead assembly**

The current steering motor is underpowered 150W motor with a 75:1 planetary gearset and will be replaced with a 200W motor with a 100:1 planetary gearset. The nominal motor voltage is 24 V with a no load speed of 5950 RPM and a stall torque of 8.92 Nm. This torque is then multiplied by the gear ratio of 100 to obtain 892 Nm and the speed is divided by 100 to obtain a no load speed of 59.5 RPM. These values can be used to create a torque VS. RPM curve for the motor control. The torque VS. RPM curve for the motor only can be seen in Figure 6. All of the mechanical and electrical specifications for the motor and gearhead can be found in Appendix E-1,2.

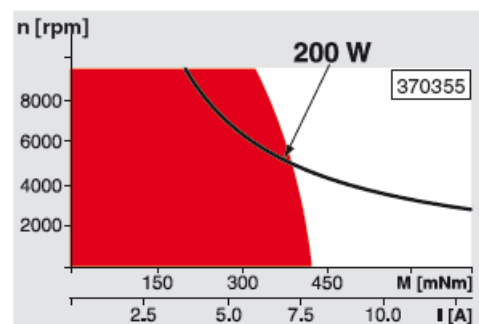

Figure 6. Torque VS. RPM curve for RE50 200W motor

## Design Concepts

- *Laser Mounting:*

The project involves two sick lasers that will emit an ultraviolet laser with a lateral range of 180 degrees in front of the ATV. One will scan about 5 feet in front of the ATV while the other scans about 20 feet ahead. This limits the locations and orientations allowed for mounting. The lasers must not cross emitter paths so to ensure good data. These lasers are also heavier in weight, requiring the mounting to be done on a rigid ground such as the frame of the ATV compared to the body. Additional parts may be required to stabilize the lasers under the stress of vehicle motion depending on the configuration used. Stress analysis must be done to determine the strength of the structure under the weight of the lasers. The lasers must also be uninterrupted in their scans of the forward environment. The position of the ATV or other sensory equipment should not inhibit this. This can cause a corruption of data and decline of performance. The possibility of placing the lower laser on a hinge to allow vertical pivoting for future development shall also be taken into consideration.



- **Design Concept 1**

This design involves mounting both lasers to the front frame of the ATV. There are positioned side by side and angled down at the appropriate degree as shown in Figure 7. Each laser will also be angled so the 90 degree mark (given a 0 to 180 degrees sweep) will point at the appropriate distance in front on the ATV on its centerline. Both lasers



Figure 7. Side-by-side configuration

can be mounted with less additional frames required but will required precise mounting to achieve the desired angles. The side by side configuration provides an equal stress distribution on the right and left frame of the ATV. However this position may cause the lasers to cross beams and interfere with each other. This can cause inaccurate data and pose significant problems in performance. This configuration is also more difficult to achieve the hinging mechanism previously discusses.

Pros

- Simple installation
- No interference from ATV components
- Uniform stress distribution

Cons

- Position not on the centerline causes more complicated calculation as coding
- Side by side configuration can cause interference between lasers
- Difficult to implement front laser hinge without interfering with other laser

## - Design Concept 2

This design involves mounting both lasers on the front frame of the ATV. The lasers are both in the centerline and will be positioned with one on top of the other. This ensures only two dimensional angling to operate appropriately and simpler hinging. The configuration will include aluminum bars bolted to the frame at six points which will house the lasers as shown in Figure 8. The bolts at which the frame will connect to the ATV are represented by the red points in the figure to the right. These bolts will connect to the rear sides of the lasers for support. These points

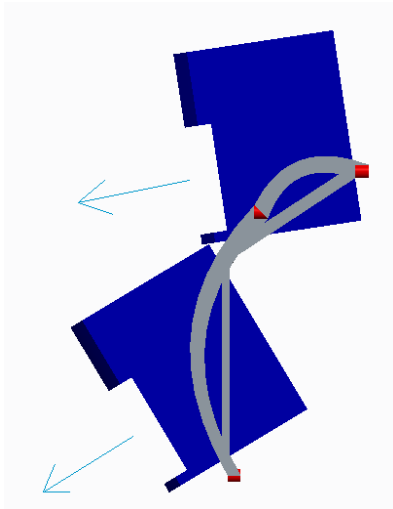

Figure 9. Side view of stacked lasers

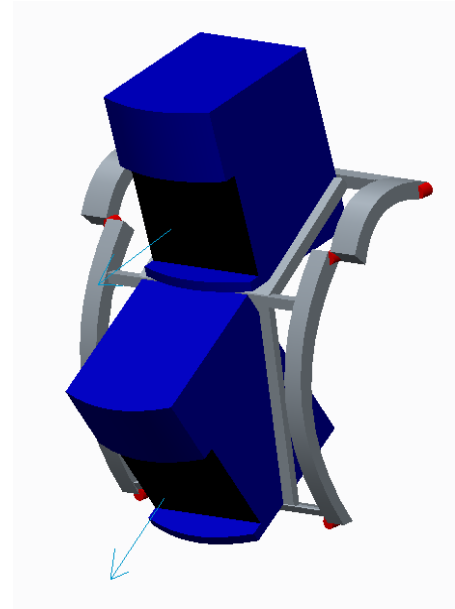

Figure 8. Trimetric view of lasers stacked on centerline

lie above, between and below the laser, preventing any heavy

torque to form on the structure due to laser weight. The angle of scanning is shown in Figure 9. The orientation allows for easier installation at the required angles.

### Pros

- Centerline position allows for easier calculation and coding
- Easier implementation of hinge
- No interference from ATV components
- No interference between lasers

### Cons

- Both lasers closer to ground and susceptible to environmental damage
- Additional machined components required
- Stress distributed towards the front of ATV frame

### - Design Concept 3

This design includes mounting one laser in front of the ATV and the other on top of the trunk on the same centerline as shown in Figure 10. The front laser would scan the closer environment while the rear would look for objects farther ahead. This configuration will require the rear laser to be placed on an aluminum box on top of the trunk. This is to give the laser the necessary height to operate without interference. A stress analysis must be done to determine whether the trunk cover will withstand the load of the additional components. The front laser will be mounted on the frame just below the rear laser's line of sight. The front laser will also require a housing similar to the one used in Design 2 for the top laser. This will provide stability to the front while allowing for easier hinging if need be.



Figure 10. Front view, front/back configuration

#### Pros

- Both lasers in centerline provides easier calculation and coding
- Equal front/rear distribution reduces clutter in one area
- Front laser not inhibited by ATV components

#### Cons

- Rear laser requires additional components to heighten
- Trunk cover may not support the weight if the laser and additional component
- Front laser closer to ground allowing for environmental damage

- *Encoder mounting:*

The encoders are an extremely important part of the sensing system of the ATV. The encoder data will be used to determine the position of the wheels and in turn the position / distance traveled by the ATV. In conjunction with a clock signal from a computer the velocity and acceleration of the ATV can be computed. The encoders were already picked out and purchased last year. The bely/pulley system to couple the encoders to the wheels was also purchased previously. Using these existing parts resulted in a limited number of possibilities for mounting locations but the belt and pulley system is clearly the best option for encoder coupling.

- **Design Concept 1**

This first design is for the left front and right front wheels. The larger pulley (green) will fit around the inner hub of the front CV axle. The encoders (yellow) will be mounted on the two upright frame tubes. The smaller pulley (red) will be mounted onto the encoder shaft. A belt will couple these two pulleys. A front and trimetric view of the subframe can be seen in Figures 11 and 12.

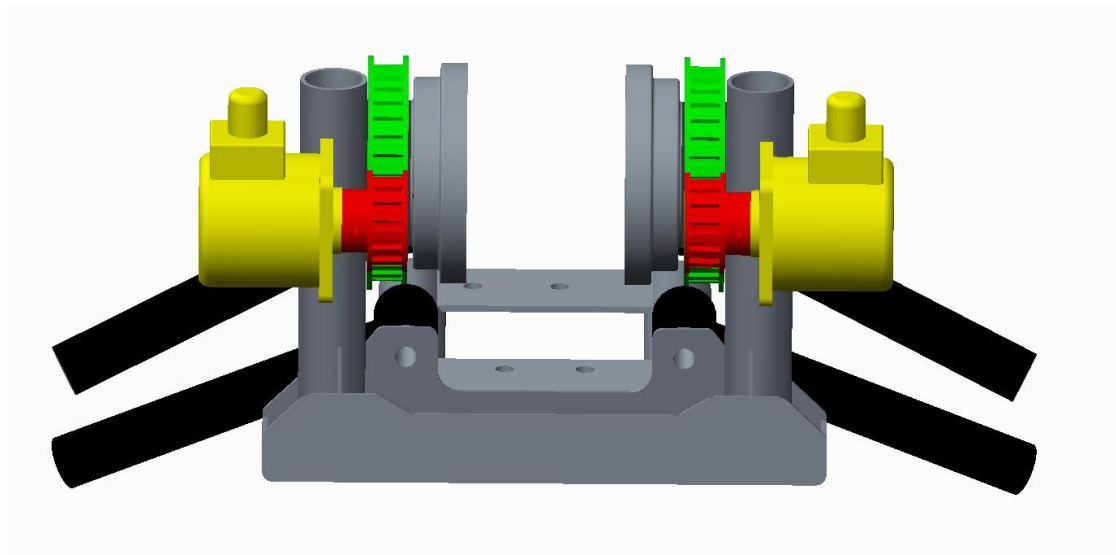

Figure 11. Front view of the front encoder mounting locations.

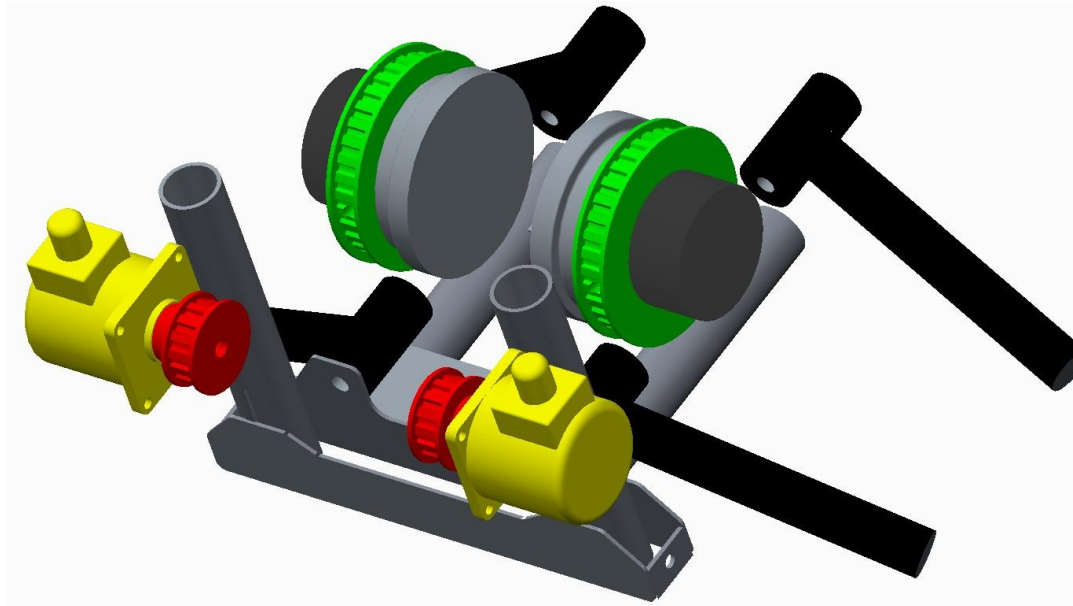

Figure 12. Trimetric view of front encoder mounting locations.

Pros

- Both encoders are in safe location
- Close proximity to tubular frame makes for simple mount manufacturing
- Location makes for easy removal / belt adjustment

Cons

- Moving belt runs very close to frame
- Moving pulleys would need to be very close to front differential, potential contact

- **Design concept 2**

This is a second option for mounting the front encoders. The larger pulley (green) will fit around the inner hub of the front CV axle furthest away from the differential. The encoders (yellow) will be mounted under the subframe. The smaller pulley (red) will be mounted onto the encoder shaft. The belt will run through the lower control arm and couple these two pulleys. A trimetric view of the encoder mounting positions can be seen in Figure 13. Since the encoders are on the underside of the ATV they are subject to damage. Figure 14 illustrates a skid plate that would protect the encoders from damage and debris.

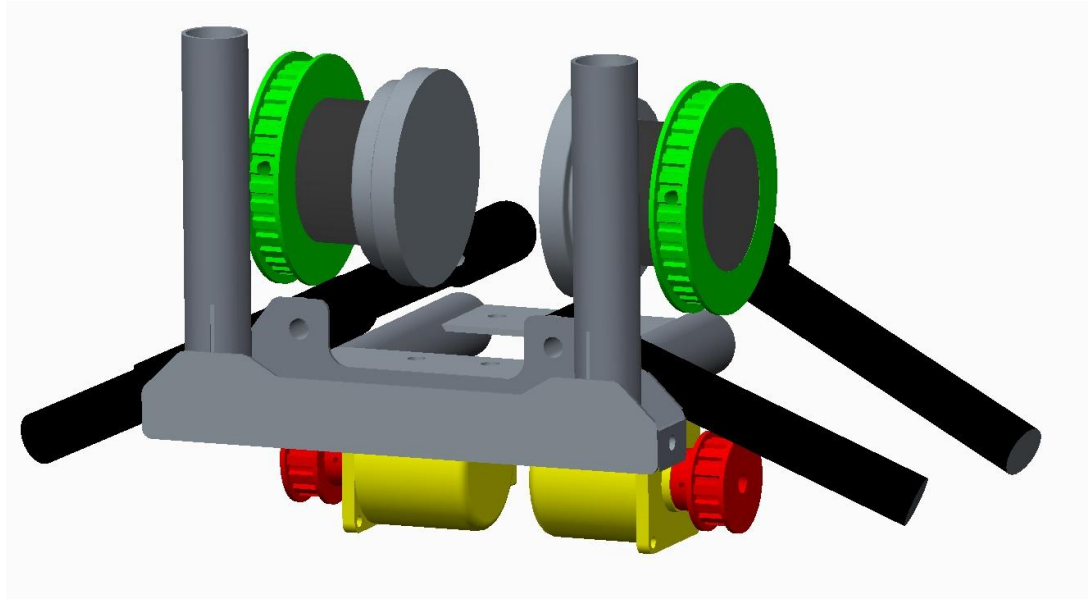

Figure 13. Trimetric view of encoders mounted under the subframe

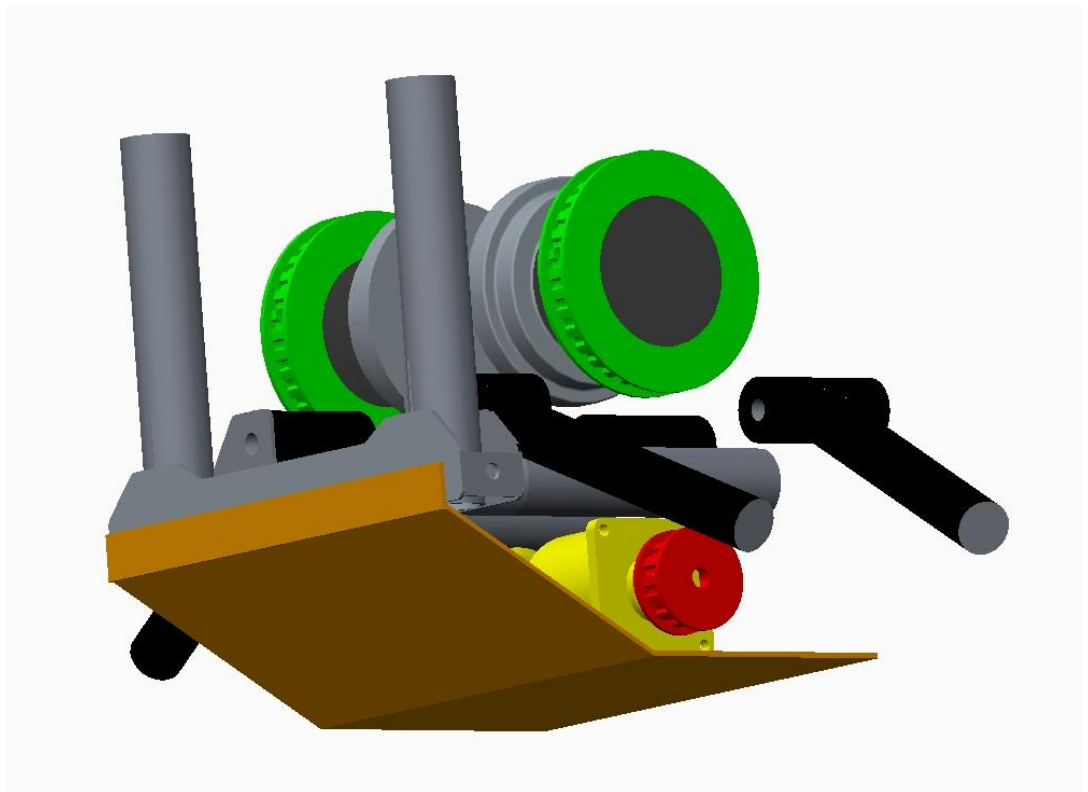

Figure 14. Added skid plate to protect encoders under the subframe

### Pros

- Lower position allows for plenty of room for moving belt
- Larger pulley not close to hitting any other components
- Placement makes for simple mounting bracket manufacturing

### Cons

- Must make extra part (skid plate)
- Reduces ground clearance by 2.5 inches.

#### - **Design Concept 3**

This Design is for the mounting orientation of the left rear and right rear encoders. With the parts supplied and the geometry of the rear subframe there was only one logical mounting solution. The larger pulley (green) will fit around the inner hub of the front CV axle furthest away from the differential. The encoders (yellow) will be mounted on top of the rear lower control arm brackets. The smaller pulley (red) will be mounted onto the encoder shaft. The belt will couple these two pulleys. Figures 15 and 16 show the rear encoder mounting solution.

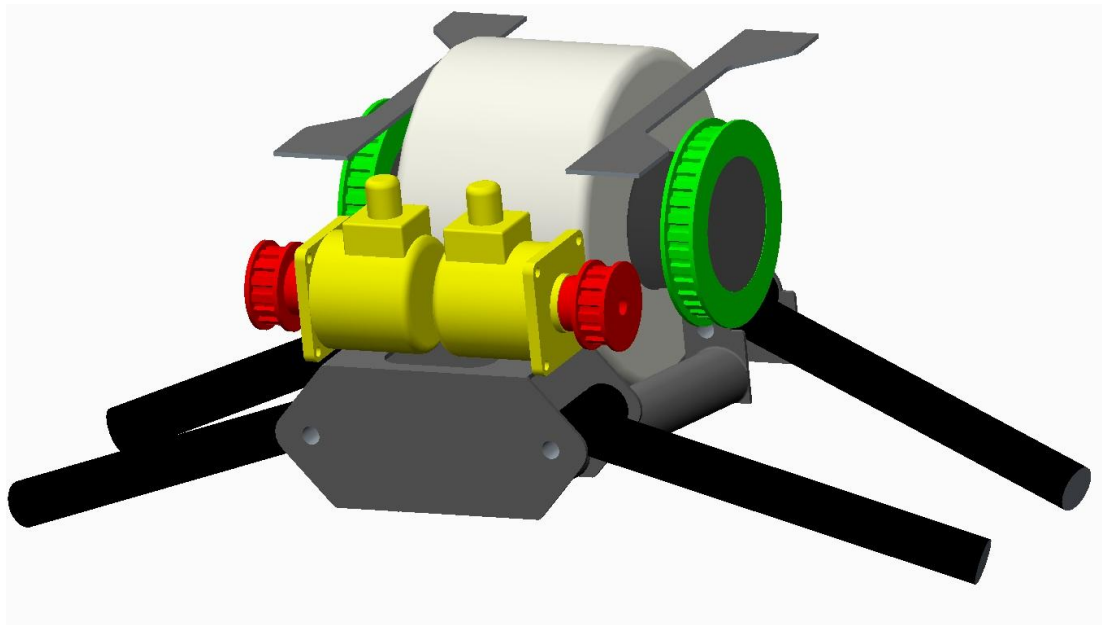

Figure 15. Trimetric view of rear encoder mounting location

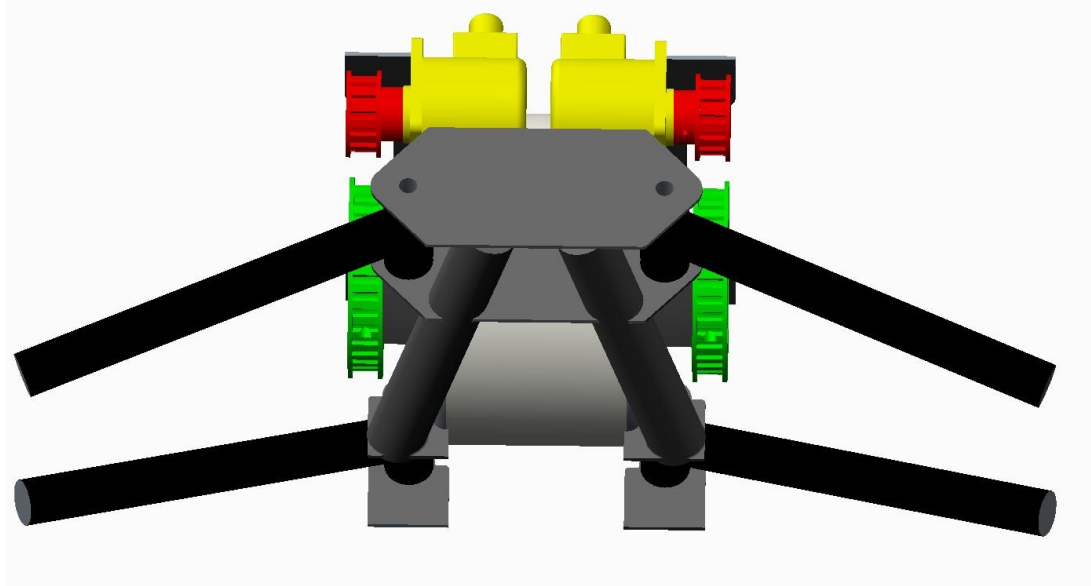

Figure 16. Bottom view of rear encoder mounting solution

### Pros

- Plenty of room for belt to move without hitting any components
- Larger pulley not close to hitting any other components
- Placement makes for simple mounting bracket manufacturing
- Placement makes for easy removal / belt adjustment

### Cons

- Possible debris getting kicked up into belt by tires



- *Steering Motor Mounting:*

The steering motor that was installed last year was under powered and needs to be replaced with one that can provide more torque. The mounting design in place now is an aluminum frame bolted to the frame of the ATV just in front of the steering column. The motor and steering column are mechanically coupled by a heavy duty chain. Since the mounting design is already in place and works very well there is no need to modify the current design heavily. There is only a need to install the new motor in place of the old one.

- **Design concept 1**

This design directly places the new motor in the same location of the old motor. There only needs to be 2 modifications to the current mounting system. The first modification is to machine a bigger diameter hole in the motor gear to accommodate the larger output shaft of the motor. After initial measurements it was found that the current mount is wide enough to fit the new motor with only recreating one piece of the aluminum mount. This plate (red) modification can be seen in Figure 17. A larger counter-bore will be machined and the mounting holes are rotated 45 degrees to be able to fit within the width constraints of the previous mount.

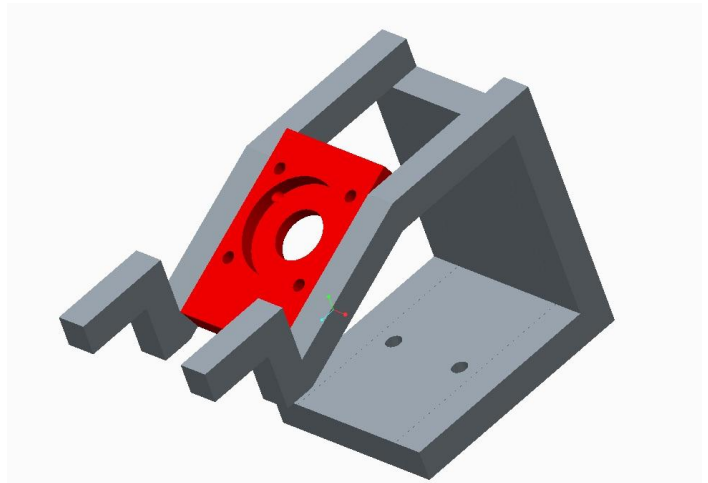

Figure 17. Modified aluminum motor mount

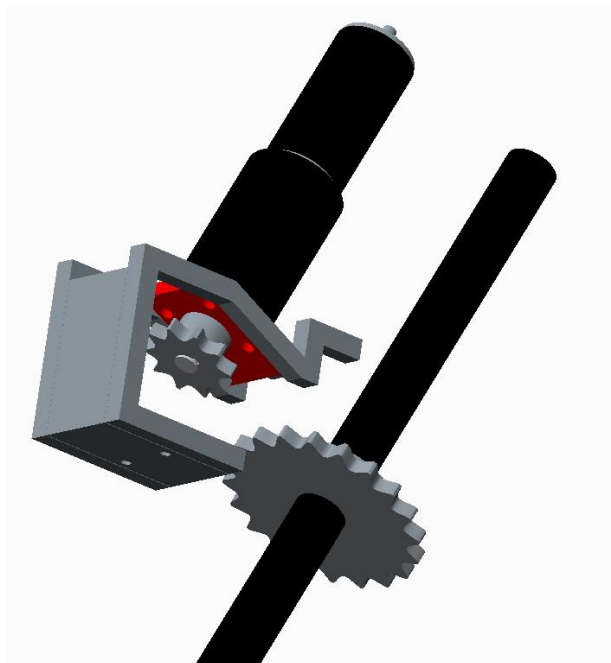

Figure 18. Full system representation with larger motor installed on new mount

### Pros

- Very simple design modification
- Utilizes existing mounts
- Can be plugged directly into existing wired connections
- Minimal fabrication and material costs

### Cons

- Larger motor will cause larger bending moment and stress in the mount.

- *GPS Mounting:*

The ProPak-G2 plus GPS will serve as an ad-hoc network between the Toughbook running ROS and the designated computer running QNX while also receiving and transmitting location data for waypoint navigation. This requires the GPS and receiver to be mounted in a place where the data will not interfere with other sensors and the environmental danger is a minimum. The three designs that were generated all accomplish these tasks. Both items have low enough weight to allow mounting on the body as compared to the frame. This gives us many location points to mount including the hood and trunk. Another consideration is that the wire between the GPS and the receiver is short (about 12 inches). The GPS and receiver cannot be mounted farther apart than this distance on the ATV. The receiver will also be connected to a 12 inch pipe which allows us for easier mounting. This pipe has no effect on the transmittance of data.

- **Design Concept 1**

The first design includes mounting the GPS and receiver on the front hood of the ATV as shown in Figures 19 and 20. The GPS will be mounted on the left or right side where there are fewer indentations. This provides a flat, easily-accessible surface for mounting. The pipe the receiver is connected to will be mounted in one of the holes on the hood.

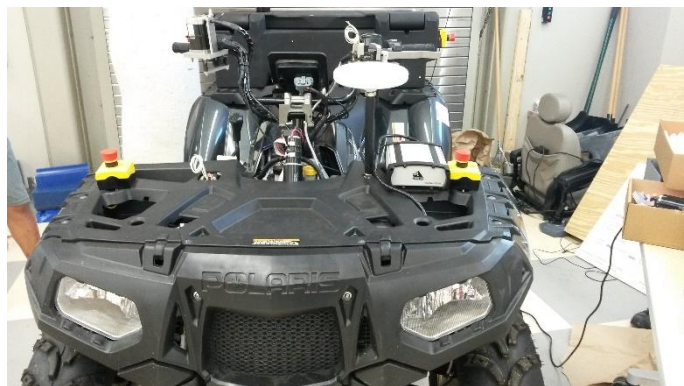

Figure X. Left side configuration

These holes are close to the diameter size of the pipe but will need further stabilization through an aluminum pipe at its ground. This position is open to the environment and

should be taken to account in the decision making process. The receiver or GPS (depending on the orientation) will also be in close proximity to the emergency cut off switch which can be hazardous.



Figure 20. Right side configuration

### Pros

- Easily accessible
- Simple to install

### Cons

- Receiver stability is low due to one ground point
- GPS open to environment
- Items close to emergency cut-off switch

### - **Design Concept 2**

The next design includes mounting the GPS on the cover of the trunk as shown in Figure 21. The cover of the trunk has a box-like shape with a hollow inside. Its thickness at most points is about 4 inches. At some points, however, the thickness decreases to about 1 inch. Such a location is where the GPS will be mounted. This position prevents the GPS from coming in contact with other items inside the trunk. The receiver can be mounted to the left of the GPS, above the trunk cover. The pipe the receiver is connected to will be placed inside the cover. A hole will be drilled where the lower end of the pipe is located in Figure 22. This is in-line with the hole located to the left of the GPS in Figure 21. The pipe will then sit inside the

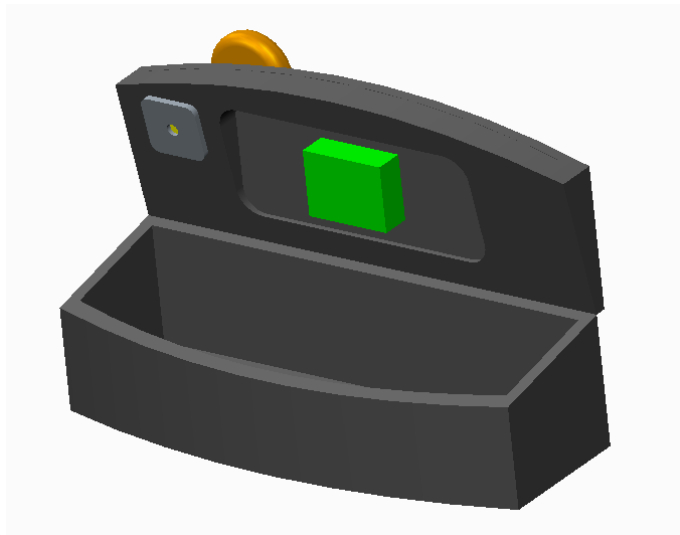

Figure 21. Trimetric view of trunk and GPS receiver

cover of the trunk and have two ground points to provide stability. An aluminum plate will also be positioned on the lower end on the inside of the truck cover. This will ground the pipe and provide a more stable environment for the receiver.

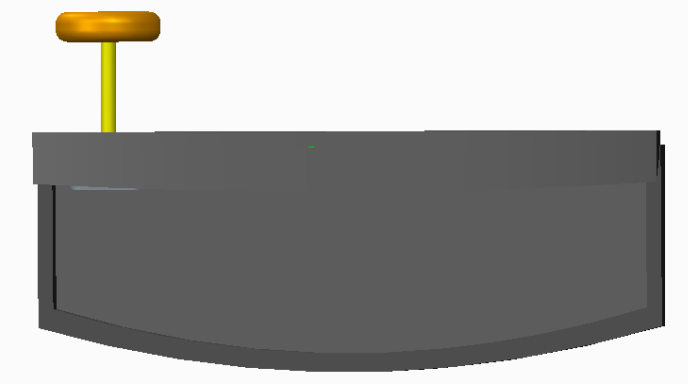

Figure 22. Top View of GPS antenna

#### Pros

- Mounted inside trunk provides protection
- Receiver is more stable than front configuration
- Easily accessible
- Reduces crowding in front of ATV

#### Cons

- Aluminum plate required for receiver stability
- GPS location adds another heat source for the trunk

- *Heat Dissipation:*

One problem that arose with last year's project was that all of the added electrical components that were installed in the rear trunk were producing excessive heat. This caused concern of overheating and possible damage to these expensive components. The trunk also serves as protection of these components to water. The excess heat must be removed from the system without compromising the components protection from water damage. The estimated amount of heat energy added from all of the components is 250-300 W. As for the level of protection from water that should be maintained, the trunk should remain protected from rain and splashes of water but it is not expected that the ATV would be submerged since it is not operable under water as well.

### - Design Concept 1

A simple but effective way of removing heat from a system is by natural convection. This entails perforating ventilation slits into the trunk while keeping the electrical components protected from water. The design in Figure 23 shows how this could be done. The best placement for these slits would be on the front and rear of trunk and not on the bottom or top. Slits on the top or bottom would leave the electrical components susceptible to water. To help protect the contents from water, panels will be placed around the slits. The slits would also allow cooler air from the environment to flow into the trunk and assist with cooling the components.

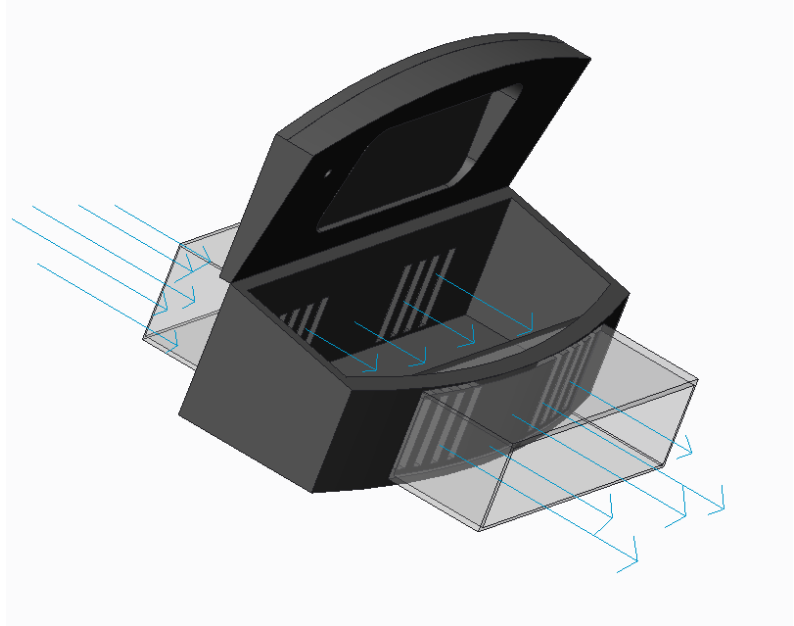

Figure 23. Trimetric view of trunk with natural convection cooling slits and protective water barrier

#### Pros

- Inexpensive
- Simple
- Consumes no extra power

#### Cons

- May not remove enough heat
- May allow entry of debris

- **Design Concept 2**

This design utilizes forced convection from fans that will be mounted into the walls of the trunk. This design has two fans, one located on the front left and one fan on the

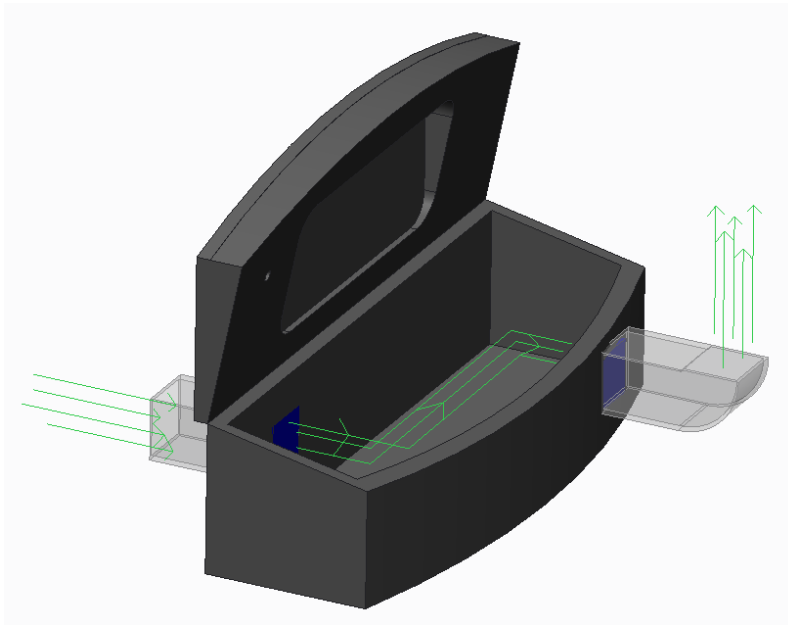

rear right. The fan in the front sucks in outside air and the fan in the back pushes air out of the trunk. This would create a good flow of air through the trunk and across the electrical components. Also to help block water from entering, panels or tubing would be placed around the fans. This is the best placement for the fans as well.

Figure 24. Trimetric view of forced convection with fans (blue)

Pros

- Relatively inexpensive
- Large heat removing capability
- Fans easily wired to power source in trunk

Cons

- Uses extra electrical power to run
- May be damaged by debris

- **Design Concept 3**

This design involves liquid cooling. This requires the installation of two heat exchangers, pump, expansion and storage tank, and tubing for the liquid. The first heat exchanger would be mounted outside of trunk with a fan attached to it. A pump would also be mounted onto the trunk with tubing connecting the two in a cyclic formation. The second heat exchanger would be in contact with either the air inside the trunk or in direct contact with the hot surfaces of the electronic components.

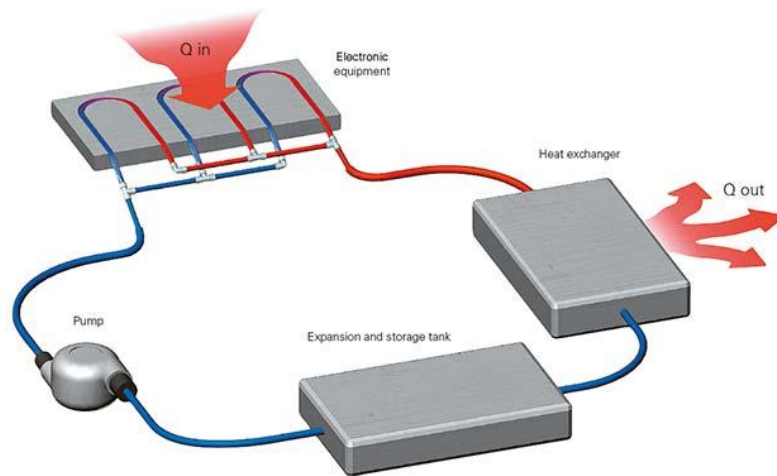

Figure 25. Liquid cooling concept diagram

Pros

- Waterproof
- Excellent heat removing capability

Cons

- Very expensive
- Uses extra electrical power to drive pump
- Very complex, lots of manufacturing

- *IMU Mounting:*

The Inertial Measurement Unit (IMU) is a crucial tool for autonomous vehicles. The IMU in use for this project is a 6 degree of freedom inertial system which uses 6 elements to measure linear acceleration and angular rate. This is used to help the computer track the ATV's position. When choosing a placement for this unit on the ATV it is best to mount the IMU centrally on the vehicle for ease of data calculation and where it will encounter the least amount of vibration or damage.

- **Design Concept 1**

The first possible location to mount the IMU is inside the trunk. The benefits of this location is that it will be protected from weather elements, receive cooling if needed, will receive small amounts of vibration, and be easily connected to the computer. The drawback with this location is that it will not be centrally located on the vehicle.

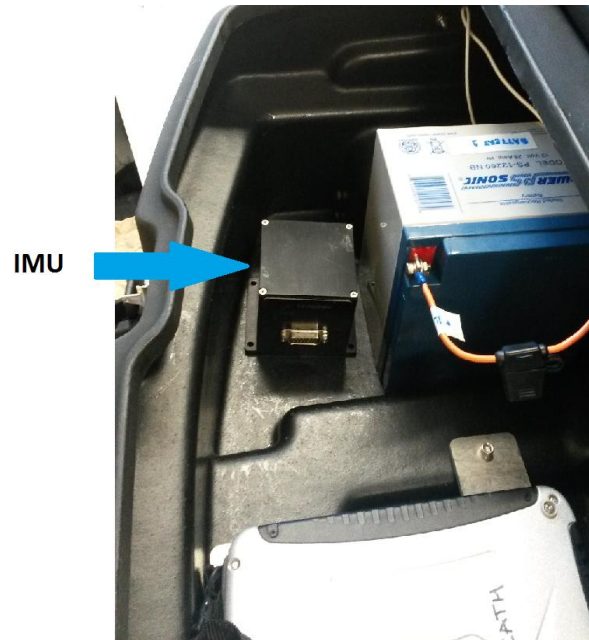

Figure 26. IMU mounting location inside trunk

- **Design Concept 2**



Figure 27. IMU mounting location between handlebars on the ATV's centerline

The second possible location for the IMU to be mounted is between the ATV's seat and handlebars. This location is beneficial in that it is located close to the center of the ATV and it will receive minimal vibrations from the ground. The drawbacks to this location is that the IMU will not be protected from weather elements and that the unit will have to be directly connected to the computer inside the trunk about three feet away. A cover will have to be put over the IMU to protect it from weather elements and also possible damage from a human driver.



- **Design Concept 3**

The third possible location for the IMU to be mounted is on the front hood of the ATV. This is beneficial in that the IMU will be in a location easy to install and the top plastic cover serves as a protective barrier around the edges. The drawbacks to this location is that it will not be protected from weather elements, have to be directly connected about five feet back to the computer inside the trunk , will receive moderate vibration from the front wheels, and is not centrally located.



Figure 28. IMU mounting location on the hood of the ATV

## Programming Needs and Control

Once all of the sensors are mounted there needs to be a way of processing the sensory data and sending outputs to the actuators. This is where the 3 laptops and wireless router will help achieve this task. Below in Figure 29 is the complete system block diagram.

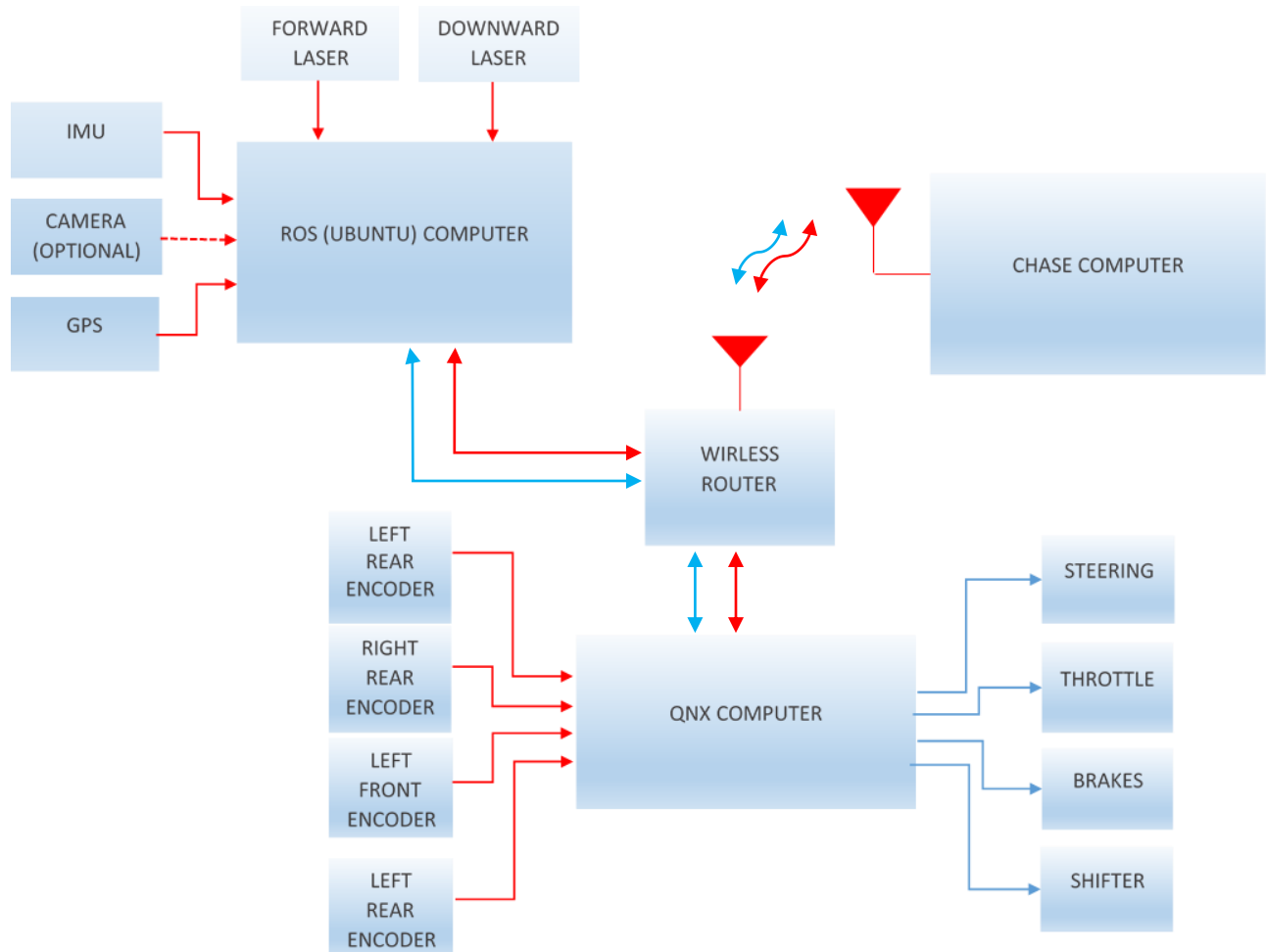

Figure 29. Full system block diagram

### - Computer Coding Concept

The computer system on the ATV consists of two computers, one running Robot Operating System (ROS) and the other QNX. ROS is an open source software that helps manage hardware and contains reusable packages. ROS will be running on a laptop with Ubuntu operating system (OS), which is a Linux based OS. The C++ programming that will control the autonomous function will be running on ROS, this consists of the main program, and several functions. QNX is a real-time operating system that will be running on the other computer on the ATV. This will receive the trajectory data from the ROS computer to control the encoders and motors.

The main program will be started by the user on the ROS system. When started it will first actuate the steering to calibrate the steering motor encoder. It will accomplish this by first turning the wheels all the way to one side until it mechanically cannot turn anymore, then turn the wheels all the way to the other side. Counting the encoder ticks will calibrate the system to identify the straight ahead position. After this the system will establish communication with all of its sensors, including the SICK laser, GPS, IMU, and camera. It will setup the protocols and keep track of the memory address of the ports for later use. The main program will then continue to run in a continuous loop awaiting instruction from the user chase computer. The user can either pick waypoint following or road following, in which the program will jump into its appropriate function. From either the waypoint or road following functions the system will output the direction and speed data which will be sent to the QNX computers to be execute. The Pseudo code for the main function is shown below.

- **Main Function Pseudo Code**

Main()

-Calibrate steering

-Initialize communications to sensors

-Wait for user selection (waypoint or road following)

    If (waypoint)

        Waypoint(s,d) - pseudo code below

    Else if (road following)

        Road\_following(s,d) - pseudo code below

    Else

        Set stop flag.

Speed = s;

Direction = d;

Brake = stop flag;

Shifter = forward;

## - **Road Following Function Pseudo Code**

Waypoint(speed,direction)

Retrieve Laser Data (angle and distance from road sides) continually

- 1) Check 1st sensor to see if any objects obstructing immediate movement
- 2) Check 1st sensor to see if in safe operating range from road sides
- 3) Check 2nd sensor to see upcoming road route

-If all three checks are successful increment speed to slow

-Continually implement the three checks again

-If all three checks are continued to be successful increment speed to medium

-Continually implement the three checks again

-If the first check fails then immediately brake and come to a halt

-If the second check fails then correct trajectory to remain in safe operating range

-After a short delay, if still failing second check, decrement speed and increase turn direction

-When safe operating range reached, turn back steering enough to remain in safe operating range then neutralize steering

-If third check reads a change in upcoming road direction then decrement speed to slow

Using ROS, the information from the SICK laser sensors are easily obtained and given by the angle and distance the object is from the sensor. This information will continuously and rapidly give the code information about three things, the distance and angle the ATV is from the sides of the road, the direction the road is heading (going straight, turning), and if there are any foreign objects in the direct route of the ATV. There have been two concepts generated in order to make the ATV

autonomous with road following. Both of which involve the same pseudo code as stated above. These two concepts will be discussed below.

There are three continuous checks that keep the ATV operating safely. These include if there are any objects directly in front of the ATV, if the ATV is in safe operating range from the road edges, and if there are any changes of directions in the road route. The first sensor will cover the first two checks while the third sensor will cover the third check. If these checks are passed then the ATV will start to move forward slowly. If the checks continue to be passed then the speed of the ATV will increase. However, if any of the checks fail, then there must be action taken by the ATV. If the sensors detect an object stationed in front of the ATV, then the ATV will immediately stop and not move until the object has been cleared. If the second check fails then the ATV will turn in order to get back in the safe zone and stay in it. Last, if the third sensor changes, then the ATV will slow its speed in order to prepare for the upcoming change in road direction.

The two different concepts involve the second and third check. The first concept will have a somewhat larger safe zone (hysteresis) for road following and allow the ATV not to slow down in a turn until the turn is immediately reached. This will allow the ATV to not have to make as many small adjustments in steering and will allow it to travel at a faster speed. This however will give more room for error in maybe hitting the sides of the road during straightaways and turns as well as have more possible obstacles in its path since the route of the ATV is wider.

The second concept will have a smaller, more precise safe zone (hysteresis) for travel in the road following, allowing it to be more controlled and have a more precise premeditated path. Also the ATV will start slowing its speed earlier when a turn in the road is indicated. Executing this concept will keep safety at the top of the line but may make the ATV run not as smoothly and will cause it to travel unnecessarily slower. These two concepts will be discussed in great detail between the ECE group members with input from the ME group members and researchers at CISCOR.

## - Waypoint Navigation Function Pseudo Code

### Basic Path Finding Algorithm:

Given a destination (x2,y2)

Record current position (x1,y1)

While ( current position != destination)

    If  $x_1 < x_2$

$x_1 \leftarrow x_1++$  ; using the encoders to determine the necessary trajectory

    else if  $x_1 > x_2$

$x_1 \leftarrow x_1--$

    If  $y_1 < y_2$

$y_1 \leftarrow y_1++$

    else if  $y_1 > y_2$

$y_1 \leftarrow y_1--$

As an introductory project objective, this basic algorithm would be advantageous in determining the functionality of the GPS system and its integration with the network of the ATV. The user will give the ATV a destination and the ATV will incrementally alter its position to match the coordinates of its destination. The program can also be integrated with the simple object detection function that will be implemented so that the ATV will know to stop whenever it detects an insurmountable object.

The advantage of the design is its simplicity in finding a path to the objects destination. However, the design only prepares for one destination and does not determine the most efficient path of arrival. For instance, if the distance needed to travel in the X direction is larger than the distance in the Y, the ATV will travel in a diagonal direction until its Y distance is met. Afterwards, the ATV will then move in a horizontal direction until it arrives to its destination. The disadvantage lies in that instead of traveling directly to the destination, the ATV could take a two path motion as shown in the figure below where the circle indicates the destination.

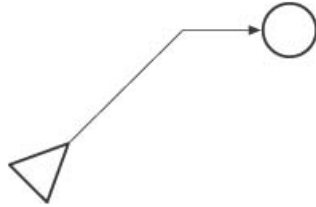

Figure 30. Basic path finding

One solution that is being explored is the Bresenham line algorithm which is used in computer science to draw a straight line on a square grid. It would be helpful due to the fact that GPS locations are based on a high resolution coordinate system similar to that of a computer. The left figure is an illustration of Bresenham's line algorithm and the figure on the right is an illustration of how it can correct the flaw of the basic path finding algorithm.

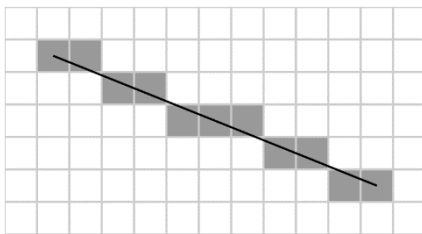

Figure 31. Bresenham's line algorithm

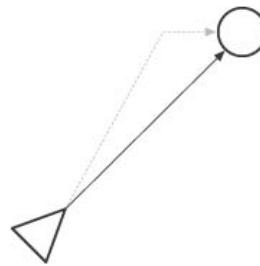

Figure 32. Application of Bresenham's line algorithm

For testing purposes, it would be ideal to test this design in an open field that is void of any major obstacles, yet large enough for the system to detect a distinct starting position and destination, relative to the precision of the GPS system.

The next plan of action will be to explore a way to help the ATV determine a path to its destination more efficiently. Ideally, the ATV should be able to determine where it is starting from and where it is going, without any input from the user at any time during the program's execution.

## Waypoint Navigation Design:

### Placing Nodes

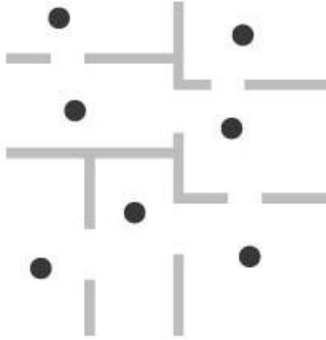

### Labeling Nodes

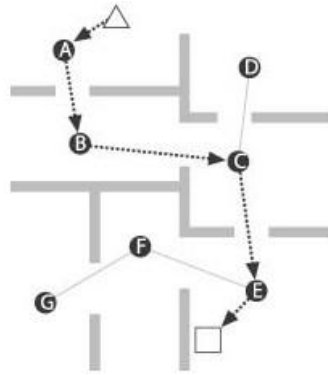

### Building a Path

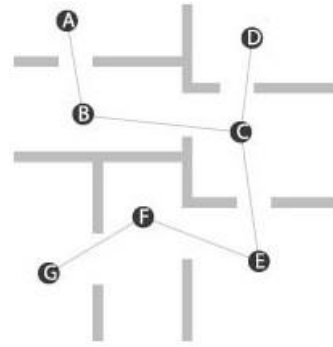

Figure 33. Placing, labeling nodes and building a path

		End						
		A	B	C	D	E	F	G
Start	A	-	B	B	B	B	B	B
	B	A	-	C	C	C	C	C
	C	B	B	-	D	E	E	E
	D	C	C	C	-	C	C	C
	E	C	C	C	C	-	F	F
	F	E	E	E	E	E	-	G
	G	F	F	F	F	F	F	-

### Functionality

1. Given GPS mapping of the terrain, the user will strategically place nodes on map such that one will always be in the “line of sight” of at least one other node
2. The nodes will be labeled in order of nodes that are most accessible (or closest to each other)
3. Depending on the beginning node, a node table will be completed to help determine the best path to the destination. Examples:
  - a. From A to G:  $A \rightarrow B \rightarrow C \rightarrow E \rightarrow G$
  - b. From F to D:  $F \rightarrow E \rightarrow D$

Figure 34. Completed node table

This design will serve as a step up from the basic path finding algorithm described above. Instead of the user sending a single destination coordinate to the system for each, we can use the waypoint navigation design to set up nodes around a map, with one node being the “home” node. Using the basic path finding algorithm as a basis function, we can create a program that causes the ATV to first find the nearest node, regardless of its current position, and use the node table to find its way “home” from the node that it started from. The advantage of this waypoint navigation is that the ATV will not need step by step coordinate input from the user in order to find out how to get home.



## **Conclusion**

There is a very large amount of conceptual designs for the mechanical portion of this project. All of the possibilities will need to be gone over thoroughly and the proper mathematical analysis done to ensure the validity and structural integrity of each design. The conceptual designs should give a great basis for the final designs and so far the project is on track for completion.

## **Future Work**

The next step will be making the decision for each concept using a decision matrix. Then the mathematical analysis of each design will be done to ensure each design is valid. At the same time the electrical/computer engineers will begin the coding to establish communication between the sensors and the computer. When this is done the algorithms for autonomous motion will be developed and tested. At the end of this semester all of the parts will be ordered and then machining and assembly can begin.

# Team 10 Autonomous ATV (GOLIATH)

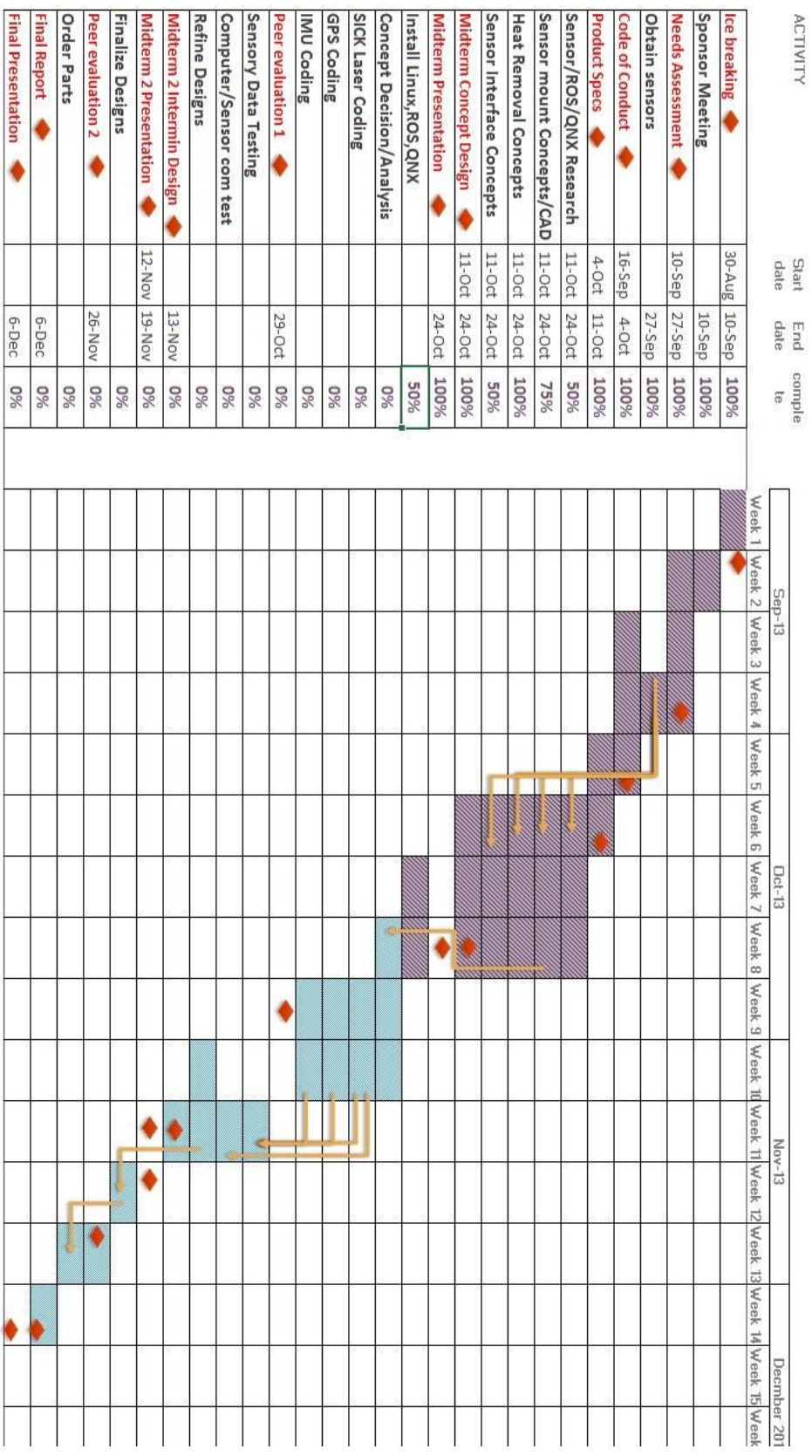

Gantt Chart

## References

- 1) <http://sicktoolbox.sourceforge.net/docs/sick-lms-technical-description.pdf>
- 2) <http://www.novatel.com/assets/Documents/Papers/ProPakG2plus.pdf>
- 3) [http://saba.kntu.ac.ir/eecd/ecourses/instrumentation/projects/reports/Poly%20Gyroscope/Producers/Crossbow/IMU/6020-0019-01\\_B\\_IMU300CC.pdf](http://saba.kntu.ac.ir/eecd/ecourses/instrumentation/projects/reports/Poly%20Gyroscope/Producers/Crossbow/IMU/6020-0019-01_B_IMU300CC.pdf)
- 4) <http://www.ctiautomation.net/PDF/Accu-Coder/Accu-Coder-725-Shaft-Encoders.pdf>
- 5) [http://www.maxonmotorusa.com/medias/sys\\_master/8807014760478/13\\_106\\_EN.pdf](http://www.maxonmotorusa.com/medias/sys_master/8807014760478/13_106_EN.pdf)
- 6) [http://www.rvok.net/tmp/Reilly.AI.for.Game.Developers/ch06\\_sect1\\_005.html](http://www.rvok.net/tmp/Reilly.AI.for.Game.Developers/ch06_sect1_005.html)
- 7) [http://www.rvok.net/tmp/Reilly.AI.for.Game.Developers/ch06\\_sect1\\_001.html](http://www.rvok.net/tmp/Reilly.AI.for.Game.Developers/ch06_sect1_001.html)
- 8) <http://www.padaengineering.com/superplate-heat-sinks.html>

# Appendix

## A-1

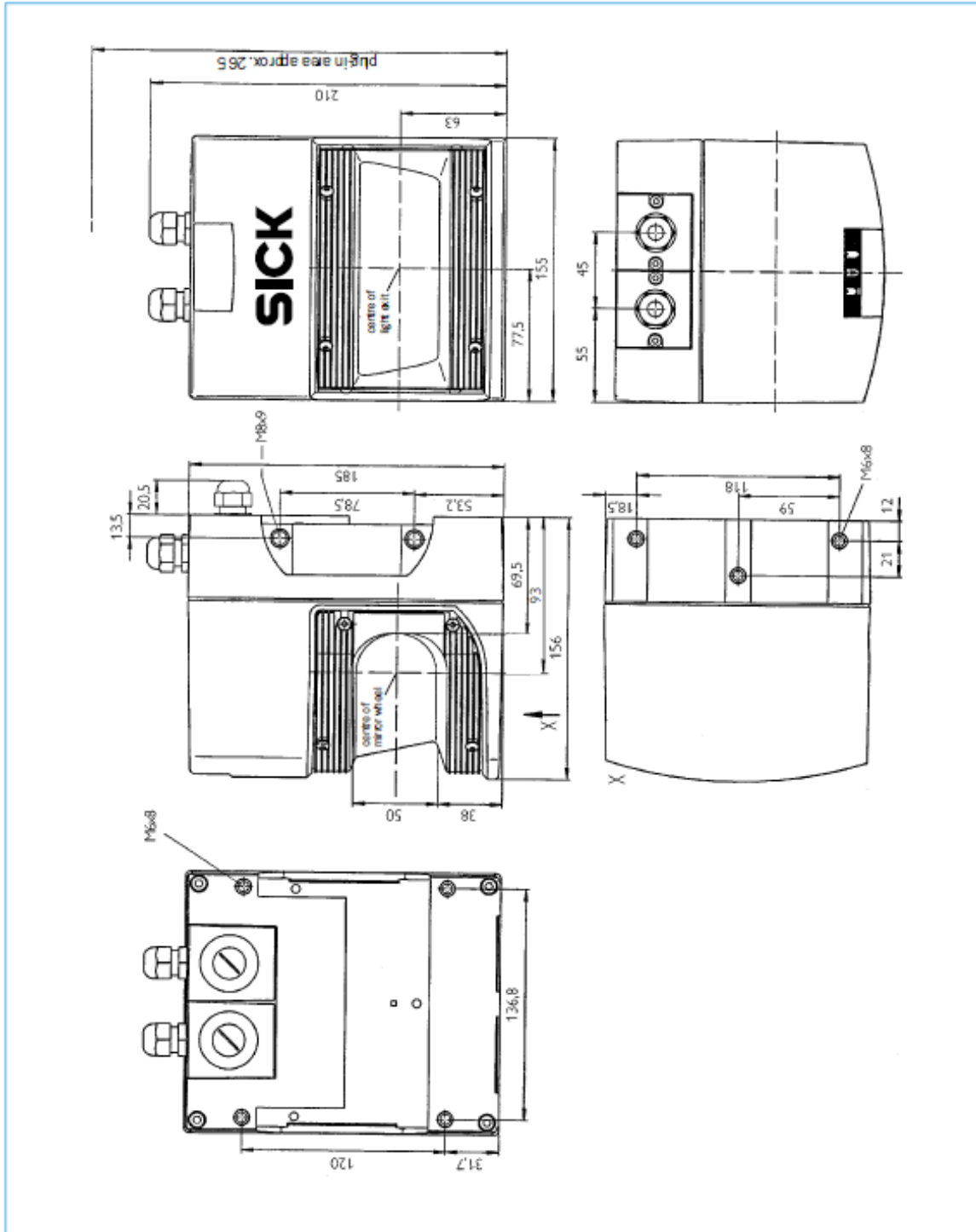



# C-1

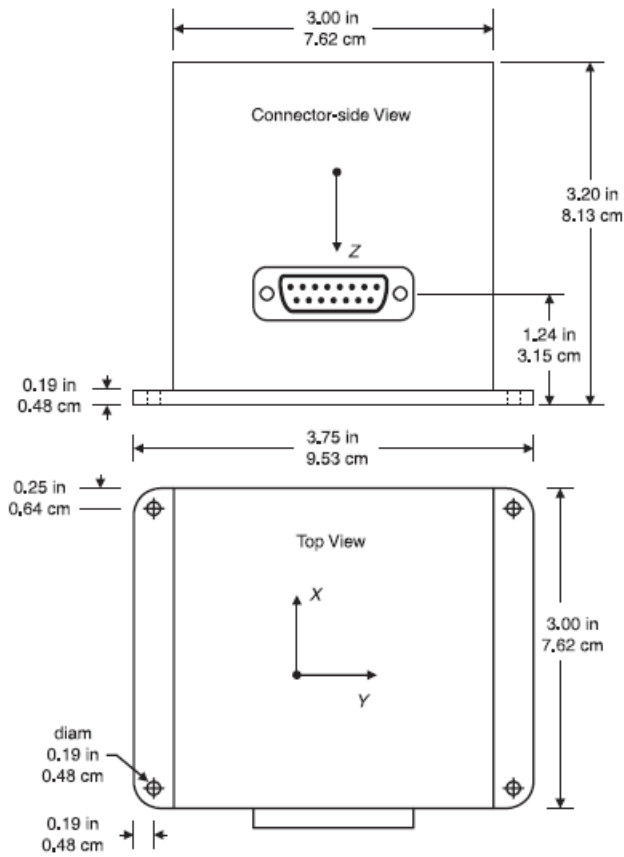

Specifications		IMU300CC-100
<b>Performance</b>		
Update Rate (Hz)		> 100
Start-up Time Valid Data (sec)		< 1
<b>Angular Rate</b>		
Range: Roll, Pitch, Yaw (°/sec)		± 100
Bias: Roll, Pitch, Yaw (°/sec)		< ± 2.0
Scale Factor Accuracy (%)		< 1
Non-Linearity (% FS)		< 0.3
Resolution (°/sec)		< 0.025
Bandwidth (Hz)		> 25
Random Walk (°/hr <sup>1/2</sup> )		< 2.25
<b>Acceleration</b>		
Range: X/Y/Z (g)		± 2
Bias: X/Y/Z (mg)		< ± 30
Scale Factor Accuracy (%)		< 1
Non-Linearity (% FS)		< 1
Resolution (mg)		< 1.0
Bandwidth (Hz)		> 75
Random Walk (m/s/hr <sup>1/2</sup> )		< 0.15
<b>Environment</b>		
Operating Temperature (°C)		-40 to +85
Non-Operating Temperature (°C)		-55 to +85
Non-Operating Vibration (g rms)		6
Non-Operating Shock (g)		1000
<b>Electrical</b>		
Input Voltage (VDC)		9 to 30
Input Current (A)		< 250
Power Consumption (W)		< 3
Digital Output Format		RS-232
Analog <sup>1</sup> Range (VDC)		± 4.096
		0 to 5.0
<b>Physical</b>		
Size	(in)	3.0 x 3.75 x 3.20
	(cm)	7.62 x 9.53 x 8.13
Weight	(lbs)	< 1.3
	(kg)	< 0.59
Connector		15 pin sub-miniature "D"

# ProPak-G2plus

## Performance<sup>1</sup>

<b>Position Accuracy</b>	
Single Point L1	1.8 m CEP
Single Point L1/L2	1.5 m CEP
WAAS L1	1.2 m CEP
WAAS L1/L2	0.8 m CEP
DGPS (L1, C/A)	0.45 m CEP
RT-20 <sup>2</sup>	< 20 cm CEP
RT-2	1 cm + 1 ppm

## Measurement Precision

L1 C/A Code	6 cm RMS
L2 P(Y) Code	25 cm RMS (AS on)
L1 Carrier Phase	0.75 mm RMS (differential channel)
L2 Carrier Phase	2 mm RMS (differential channel)

## Data Rate

Measurements	20 Hz
Position	20 Hz

## Time to First Fix

Cold Start <sup>3</sup>	50 s
Warm Start <sup>4</sup>	40 s
Hot Start <sup>5</sup>	30 s

## Signal Reacquisition

L1	0.5 s (typical)
L2	1.0 s (typical)

<b>Time Accuracy<sup>6</sup></b>	<b>20 ns RMS</b>
----------------------------------	------------------

<b>Velocity Accuracy</b>	<b>0.03 m/s RMS</b>
--------------------------	---------------------

## Dynamics

Velocity <sup>7</sup>	514 m/s
Vibration	4 G (sustained tracking)

<b>Altitude<sup>7</sup></b>	<b>18,288 m</b>
-----------------------------	-----------------

## Physical & Electrical

<b>Size</b>	<b>185 x 154 x 71 mm</b>
-------------	--------------------------

<b>Weight</b>	<b>1.0 kg</b>
---------------	---------------

## Power

Input Voltage <sup>8</sup>	+9 to +18 VDC
Power Consumption	2.5 W (typical)

## Antenna LNA Power Output

Output Voltage	+5 VDC
Maximum Current	100 mA

## Communication Ports

- 2 RS-232 or RS-422 serial ports capable of 230,400 bps
- 1 RS-232 serial port capable of 230,400 bps
- 1 USB port capable of 5 Mbps

## Input/Output Connectors

Power	4-pin LEMO
Antenna Input	TNC female
External Oscillator	BNC female
COM1	DB-9 male
COM2	DB-9 male
AUX (COM3)	DB-9 male
I/O	DB-9 female

## Environmental

<b>Temperature</b>	
Operating	-40°C to +75°C
Storage	-45°C to +95°C
<b>Humidity</b>	95% non-condensing
<b>Waterproof</b>	IEC 60529 IPX7
<b>Vibration (operating)</b>	
Random	MIL-STD-202F 214A
Sinusoidal	SAE J1211 4.7
<b>Shock (non-operating)</b>	IEC 68-2-27 Ea

<b>Regulatory</b>	<b>FCC Class B, CE</b>
-------------------	------------------------

*E-1*



# RE 50 Ø50 mm, Graphite Brushes, 200 Watt

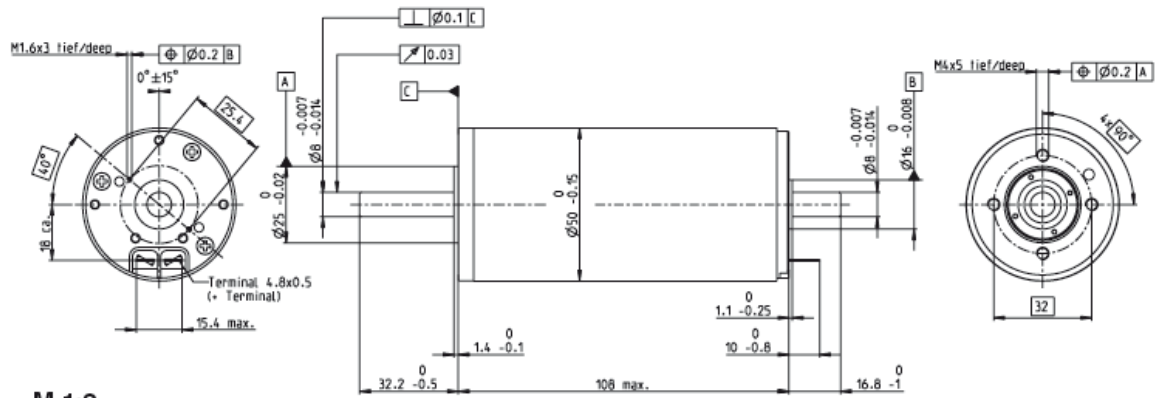

M 1:2

- Stock program
- Standard program
- Special program (on request)

### Part Numbers

370354 370355 370356 370357

### Motor Data

Motor Data	370354	370355	370356	370357	
<b>Values at nominal voltage</b>					
1 Nominal voltage	V	24	36	48	70
2 No load speed	rpm	5950	5680	4900	2760
3 No load current	mA	236	147	88.4	27.4
4 Nominal speed	rpm	5680	5420	4620	2470
5 Nominal torque (max. continuous torque)	mNm	405	418	420	452
6 Nominal current (max. continuous current)	A	10.8	7.07	4.58	1.89
7 Stall torque	mNm	8920	8920	7370	4340
8 Starting current	A	232	148	78.9	17.9
9 Max. efficiency	%	94	94	94	92
<b>Characteristics</b>					
10 Terminal resistance	Ω	0.103	0.244	0.608	3.9
11 Terminal inductance	mH	0.0717	0.177	0.423	2.83
12 Torque constant	mNm/A	38.5	60.4	93.4	242
13 Speed constant	rpm/V	248	158	102	39.5
14 Speed / torque gradient	rpm/mNm	0.668	0.638	0.666	0.638
15 Mechanical time constant	ms	3.75	3.74	3.78	3.74
16 Rotor inertia	gcm <sup>2</sup>	536	560	542	560

### Specifications

<b>Thermal data</b>	
17 Thermal resistance housing-ambient	3.8 K/W
18 Thermal resistance winding-housing	1.2 K/W
19 Thermal time constant winding	71.7 s
20 Thermal time constant motor	1370 s
21 Ambient temperature	-30...+100°C
22 Max. permissible winding temperature	+125°C
<b>Mechanical data (preloaded ball bearings)</b>	
23 Max. permissible speed	9500 rpm
24 Axial play at axial load < 11.5 N	0 mm
> 11.5 N	0.1 mm
25 Radial play	preloaded
26 Max. axial load (dynamic)	30 N
27 Max. force for press fits (static) (static, shaft supported)	150 N
28 Max. radial loading, 15 mm from flange	6000 N
	110 N

<b>Other specifications</b>	
29 Number of pole pairs	1
30 Number of commutator segments	15
31 Weight of motor	1100 g

Values listed in the table are nominal. Explanation of the figures on page 71.

Industrial version with radial shaft seal ring (resulting in increased no-load current)

### Operating Range

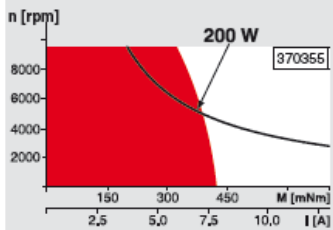

### Comments

**Continuous operation**  
In observation of above listed thermal resistance (lines 17 and 18) the maximum permissible winding temperature will be reached during continuous operation at 25°C ambient. = Thermal limit.

**Short term operation**  
The motor may be briefly overloaded (recurring).

— Assigned power rating

### maxon Modular System

Overview on page 20 - 25

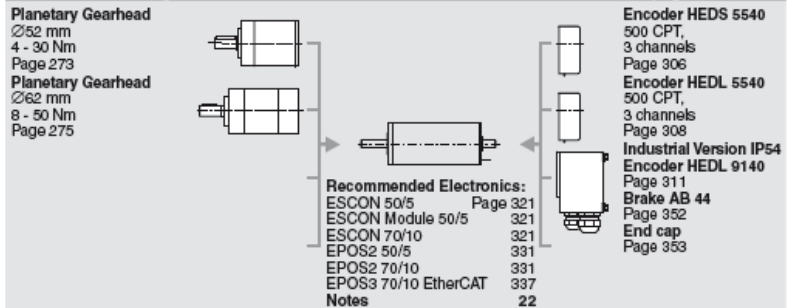

# Planetary Gearhead GP 62 A Ø62 mm, 8–50 Nm

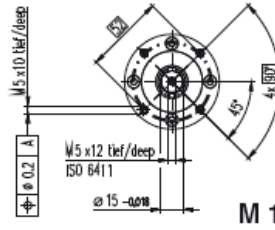
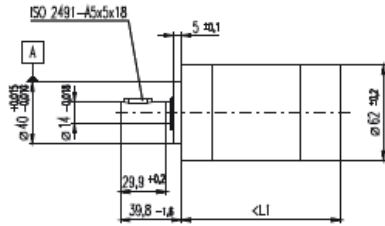

### Technical Data

Planetary Gearhead	straight teeth
Output shaft	steel
Bearing at output	ball bearing
Radial play, 7 mm from flange	max. 0.08 mm
Axial play	max. 1 mm
Max. permissible axial load	120 N
Max. permissible force for press fits	1000 N
Sense of rotation, drive to output	=
Recommended input speed	< 3000 rpm
Recommended temperature range	-30...+140°C
Number of stages	1 2 3
Max. radial load, 24 mm from flange	240 N 360 N 570 N

maxon gear

- Stock program
- Standard program
- Special program (on request)

### Part Numbers

	110499	110501	110502	110503	110504	110505	110506	110507	110508
<b>Gearhead Data</b>									
1 Reduction	5.2:1	19:1	27:1	35:1	71:1	100:1	139:1	181:1	236:1
2 Reduction absolute	57/11	359/187	324/121	153/44	216225/3179	304287/2027	105193/1331	57723/484	41553/176
3 Max. motor shaft diameter	mm 8	8	8	8	8	8	8	8	8
4 Number of stages	1	2	2	2	3	3	3	3	3
5 Max. continuous torque	Nm 8	25	25	25	50	50	50	50	50
6 Intermittently permissible torque at gear output	Nm 12	37	37	37	75	75	75	75	75
7 Max. efficiency	% 80	75	75	75	70	70	70	70	70
8 Weight	g 950	1250	1250	1250	1540	1540	1540	1540	1540
9 Average backlash no load	° 1.0	1.5	1.5	1.5	2.0	2.0	2.0	2.0	2.0
10 Mass inertia	gcm <sup>2</sup> 109	100	105	89	104	105	102	88	89
11 Gearhead length L1	mm 72.5	88.3	88.3	88.3	104.2	104.2	104.2	104.2	104.2



### maxon Modular System

+ Motor	Page	+ Sensor	Page	Brake	Page	Overall length [mm] – Motor length + gearhead length + (sensor/brake) + assembly parts							
RE 50, 200 W	106				180.6	196.4	196.4	196.4	212.3	212.3	212.3	212.3	212.3
RE 50, 200 W	106	HEDS 5540	306		201.3	217.1	217.1	217.1	233.0	233.0	233.0	233.0	233.0
RE 50, 200 W	106	HEDL 5540	308		201.3	217.1	217.1	217.1	233.0	233.0	233.0	233.0	233.0
RE 50, 200 W	106	HEDL 9140	311		243.0	258.8	258.8	258.8	274.7	274.7	274.7	274.7	278.7
RE 50, 200 W	106			AB 44	352	243.0	258.8	258.8	274.7	274.7	274.7	274.7	278.7
RE 50, 200 W	106	HEDL 9140	311	AB 44	352	256.0	271.8	271.8	271.8	287.7	287.7	287.7	287.7
EC 45, 250 W	183				216.6	232.4	232.4	232.4	248.3	248.3	248.3	248.3	248.3
EC 45, 250 W	183	HEDL 9140	310		232.2	248.0	248.0	248.0	263.9	263.9	263.9	263.9	263.9
EC 45, 250 W	183	Res 26	316		216.6	232.4	232.4	232.4	248.3	248.3	248.3	248.3	248.3
EC 45, 250 W	183			AB 28	349	224.0	239.8	239.8	239.8	255.7	255.7	255.7	255.7
EC 45, 250 W	183	HEDL 9140	310	AB 28	349	241.0	256.8	256.8	256.8	272.7	272.7	272.7	272.7