



FAMU/FSU College of Engineering

Department of Mechanical Engineering

Final Report

Team 10 Autonomous ATV

Group Members:

Michael Brazeau Marc Akbar Jeremy Hammond
Omesh Dalchand Lester Kendrick Merrick Salisbury Nahush Kulkarni

Sponsors:

Center for Intelligent Systems, Control, and Robotics (CISCOR)

Advisors:

Dr. Chiang Shih Dr. Kamal Amin
Dr. Oscar Chuy Dr. Emmanuel Collins

Instructor:

Dr. Kamal Amin

4/17/2014

Table of Contents

<i>Abstract/Summary</i>	2
<i>Acknowledgements</i>	2
<i>Project Overview</i>	3-4
<i>Design and Analysis</i>	5-39
<i>Function Analysis</i>	5-7
<i>Design Concepts, Selection, Final Design, Machining, Assembly</i>	8-41
<i>Lasers</i>	8-14
<i>Encoders</i>	15-23
<i>Steering Motor</i>	24-27
<i>GPS</i>	28-32
<i>Heat Dissipation</i>	33-38
<i>IMU</i>	39-341
<i>Programming needs and Control</i>	42-52
<i>Design for Manufacturability, Reliability and Cost</i>	53-54
<i>Risk and Reliability Assesment</i>	55
<i>Environmental Safety</i>	56
<i>Communications</i>	56
<i>Conclusion</i>	57
<i>Recommendations for Future Work</i>	57
<i>Procurement/Budget/Resources</i>	59
<i>Gantt Chart</i>	59
<i>References</i>	60
<i>Appendix</i>	61-75

Abstract/Summary

This final report will illustrate and explain all of the conceptual designs, final designs, analysis and manufacturing needed to reach the end goal of creating a fully functional autonomous ATV. The scope of this project is very large. It ranges from mounting up to ten sensors, powering those sensors and making the sensors communicate with onboard computers. There will also be C++ code development of autonomous algorithms. This project will span the fields of mechanical engineering, fluid dynamics, computer/software engineering and electrical engineering.

Acknowledgements

We want to thank Dr. Chuy for his invaluable help with all aspects of the project. We also extend thanks to Dr. Collins, Dr. Amin, Dr. Frank, and Dr. Shih for their part in the guidance and advising of the team. We also want to thank everyone involved at the Center for Intelligent Systems, Controls, and Robotics (CISCOR) for supplying a workspace and necessary materials to build this project. We would also like to thank Ryan David-Reyes at CISCOR as well as Nahush Kulkarni for their help in the computer programming of this project.

Project Overview

Problem Statement:

CISCOR currently has multiple robotic platforms used in research ranging from bio-inspired legged walking robots to four wheel skid-steered robots. Some of these platforms are able to function outside on limited terrain types. This induces a need for a vehicle that is able to traverse many types of difficult terrains. Thus, the ATV was a clear choice for a platform to automate. Last year, actuators were installed onto the controls of the ATV. The task this year is to incorporate sensing and computer systems to interface with these actuators and develop the algorithms for autonomous motion.

- *Justification/Background:*

Research into autonomous ground vehicles is growing rapidly. There is a need for vehicles to perform tasks without any physical interaction or human control. These tasks can range from dangerous search and rescue missions to civilian vehicles driving themselves through city streets. CISCOR is currently conducting research with autonomous mobile robots with emphasis on path planning and efficiency. This same type of research is desired with a more robust system that can handle difficult terrains and obstacles, as well as normal driving situations on a paved surface. For this reason, an ATV was chosen as the new platform to develop autonomous control.

- *Objective:*

The main objective is to integrate a sensory system that will scan the surrounding environment. This data is then used to compute a trajectory for the ATV to perform waypoint navigation and road following autonomously. These sensors include Encoders, SICK laser sensors, IMU (Inertial Measurement Unit), GPS system for waypoint navigation, and possibly a stereoscopic camera. Problems including the overheating of the motor-drivers and an underpowered steering actuator will also be resolved. Waterproofing the sensors, encoders and actuators must also be done to ensure all-terrain capabilities. To assist with safety, a way to shut down the ATV remotely will be developed. All of the objectives will be finished by April 2014

- *Methodology:*

In order to deliver a fully functioning autonomous ATV by the end of April many important milestones need to be met. This will be done by assigning each student a specific task for them to work on for a majority of the project. The team consists of 3 mechanical engineering students, 3 electrical engineering students and one computer science student.

The first step will be for the mechanical engineers to develop concepts for the new steering system, trunk cooling system, wheel encoder mounting, and laser/GPS/IMU sensor mounting. At the same time the electrical engineers will begin to research communication protocols for the sensors and become familiar with ROS (Robot Operating System) and QNX operating system. The next step will be the rapid prototyping and mathematical analysis of the mechanical systems. This will require careful wiring of the power and communication between the sensors, actuators and the computers. High level control law for autonomous motion will then be developed.

The last step will be to manufacture and test all necessary mechanical components for sensor mounting and implement the computer cooling system. Also the C++ coding for communication, data acquisition, and trajectory computation will be fully developed for waypoint to waypoint navigation and road following.

- *Constraints*

There is a budget of approximately 1500.00 USD set aside for building material. Most of the sensors and computers are already purchased. A large hurdle to overcome will be scheduling time for all team members to work on the project at specific times. Each student has a separate and unique schedule that needs to be taken into account. The largest constraint on this project will be time. There are many objectives to complete and all of them must be met by the end of April 2014.

Design and Analysis

- *Functional analysis*

The following is a list of all components and the electrical/mechanical specifications of each component.

- **Toughbook Laptop Computer**

The project will incorporate 2 of these laptops. One will be running Ubuntu and ROS and receiving sensory data from all of the sensors with exception of the encoders. This computer will then process the sensory data and compute a trajectory. A single board computer will also be onboard the ATV and will be running QNX operating system. This computer will receive sensory data from all of the encoders and send the data back to the laptop that will then send commands to the actuators. The second Laptop will be used as a “chase” computer, allowing the users to monitor the system through a wireless connection with a router onboard the ATV. The laptops come with an Intel i5 processor and 4GB of RAM.

- **SICK LMS 200 Laser Distance Measurement System**

The project will incorporate 2 of these distance sensors. One will be mounted in such a way that it can view 5 feet directly in front of the vehicle and the other sensor will be mounted to view about 15 feet in front of the vehicle. The laser can scan 180 degrees with an angular resolution of 0.25 degrees. This yields 720 data points per laser pass. It has a maximum range of 80 meters with a resolution of 1 centimeter and an error of ± 4.0 centimeters. The laser communicates via serial (RS232) and outputs the distances measured in centimeters [cm]. Supply voltage is 24VDC and draws a continuous current of 1.8 A. Figure 1 shows how the laser scans surrounding objects. All mechanical dimensions can be found in Appendix A-1.

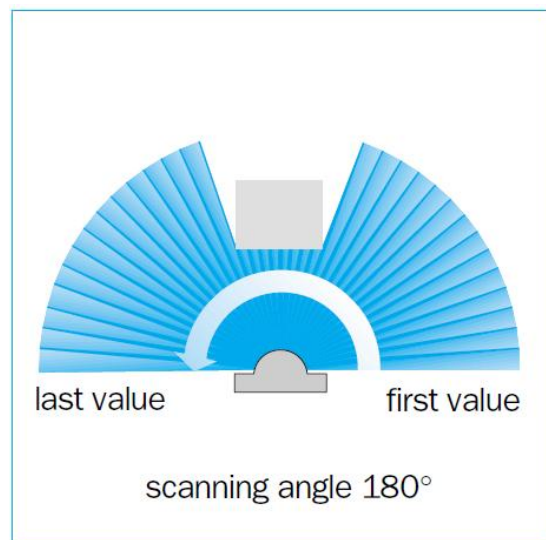

Figure 1: SICK LMS 200 scanning profile

- **Accu-Coder model 725 Encoder**

The ATV will use 4 encoders, one on each wheel to keep track of its position. The encoder, when run in quadrature, will output 30,000 counts per revolution. This is done by 2 IR sensors inside the encoder that are 180 degrees out of phase. This gives quadruple the resolution using the same sensor wheel and also gives the option to sense the direction of rotation using a few lines of code. The output of the encoder can be seen in Figure 2. The supply voltage is 4.75 – 28 VDC. Max shaft speed is 8000 RPM with a max frequency of 1 MHz. The mechanical dimensions and specifications can be found in Appendix B-1.

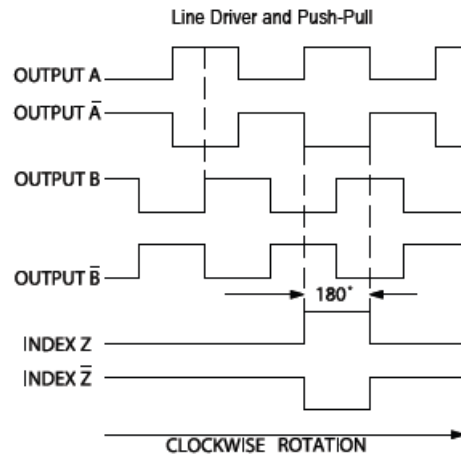

Figure 2: Accu-coder model 725 data output

- **Crossbow Inertial Measurement Unit (IMU)**

The linear accelerations and angular velocity in all 3 spatial dimensions must be known to be able to control the ATV in between GPS signals and also to detect possible vehicle rollover. The IMU is a 6 degree of freedom sensor that utilizes solid state accelerometers and MEMS gyroscopic sensors to measure angular



Figure 4: Crossbow Inertial Measurement Unit

rate of rotation along the 3 spatial dimensions as shown in Figure 3. Supply voltage is 9-30 VDC and consumes energy at a rate of 3 W. It can measure an

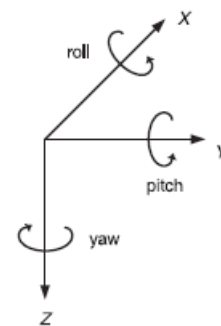

Figure 3: 3 dimensional coordinate axes with 6

degrees of freedom. It can measure an angular velocity of ± 100 degrees/sec with a resolution of 0.025 degrees/sec. The IMU can measure linear accelerations of $\pm 2g$ with a resolution of less than 0.001g. Communication protocol is RS232. All mechanical dimensions and specifications can be found in Appendix C-1.

- **NovAtel ProPak-G2plus GPS**

For waypoint to waypoint autonomous navigation a GPS system is needed to locate the ATV on the face of the earth with precise coordinates. The ProPak-G2 can give position accuracy within a 1.8 meter diameter circle. Supply voltage is 9 to 18 VDC and consumes energy at a rate of 2.5 W. Communication is serial (RS232) or optional USB. Data output rate is 20 Hz and may take up to 50 seconds to get the first location fix. To receive the GPS signals from the satellites a Precise Positioning Management (PPM) L1 passive antenna will be installed. All mechanical dimensions and electrical specifications can be found in Appendix D-1.



Figure 5: NovAtel ProPak-G2plus GPS receiver

- **Maxon RE50 Graphite Brushed DC motor / GP 62 planetary gearhead assembly**

The current steering motor is underpowered 150W motor with a 75:1 planetary gearset and will be replaced with a 200W motor with a 100:1 planetary gearset. The nominal motor voltage is 24 V with a no load speed of 5950 RPM and a stall torque of 8.92 Nm. This torque is then multiplied by the gear ratio of 100 to obtain 892 Nm and the speed is divided by 100 to obtain a no load speed of 59.5 RPM. These values can be used to create a Torque vs. RPM curve used for the motor control. The Torque vs. RPM curve for the motor only can be seen in Figure 6. All of the mechanical and electrical specifications for the motor and gearhead can be found in Appendix E-1,2.

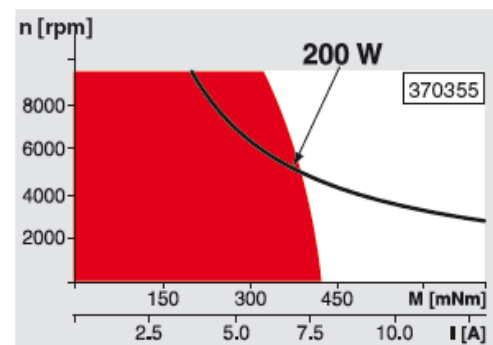

Figure 6: Torque VS. RPM curve for RE50 200W motor

Design Concepts, Selection, Final Design, Machining & Assembly

- *Laser Mounting*

The project involves two sick lasers that will emit laser pulses with a lateral range of 180 degrees in front of the ATV. One will scan about 5 feet in front of the ATV while the other scans about 15 feet ahead. This limits the locations and orientations allowed for mounting. The lasers must not cross emitter paths so to ensure correct data acquisition. These lasers are also heavier in weight, requiring the mounting to be done on a rigid ground such as the frame of the ATV compared to the body. Additional parts may be required to stabilize the lasers under the stress of vehicle motion depending on the configuration used. Stress analysis must be done to determine the strength of the structure under the weight of the lasers. The lasers must also be uninterrupted in their scans of the forward environment. The position of the ATV or other sensory equipment should not inhibit this. This can cause a corruption of data and a decline of performance. The possibility of placing the lower laser on a hinge to allow vertical pivoting for future development may also be taken into consideration.

- Design Concept 1

This design involves mounting both lasers to the front frame of the ATV. They are positioned side by side and angled down at the appropriate degree as shown in Figure 7. Each laser will also be angled so the 90 degree mark (given a 0 to 180 degrees sweep) will point at the appropriate distance in front on the ATV on its centerline. Both lasers can be mounted with less additional frames required but will require precise mounting to achieve the desired angles.



Figure 7: Side-by-side configuration

The side by side configuration provides an equal stress distribution on the right and left frame of the ATV. However this position may cause the lasers to cross beams and interfere with each other. This can cause inaccurate data and pose significant problems in performance. This configuration is also more difficult to achieve the hinging mechanism previously discussed.

Pros

- Simple installation
- No interference from ATV components
- Uniform stress distribution

Cons

- Position not on the centerline causes more complicated calculation as coding
- Side by side configuration can cause interference between lasers
- Difficult to implement front laser hinge without interfering with other laser

- **Design Concept 2**

This design involves mounting both lasers on the front frame of the ATV. The lasers are both in the centerline and will be positioned with one on top of the other. This ensures only two dimensional angling to operate appropriately and simpler hinging. The configuration will include aluminum bars bolted to the frame at six points which will house the lasers as shown in Figure 8. The bolts at which the frame will connect to the ATV are represented by the red points in the figure to the right. These bolts will connect to the rear sides of the lasers for support. These points lie above, between and below the laser,

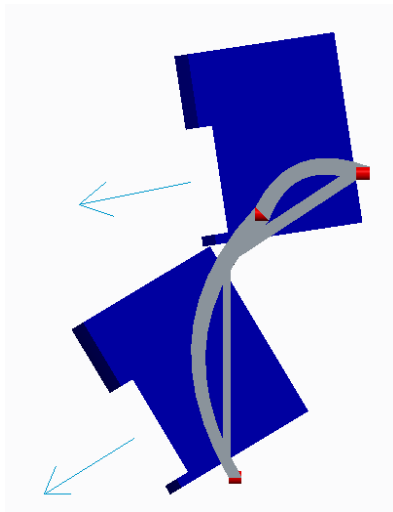

Figure 9: Side view of stacked lasers

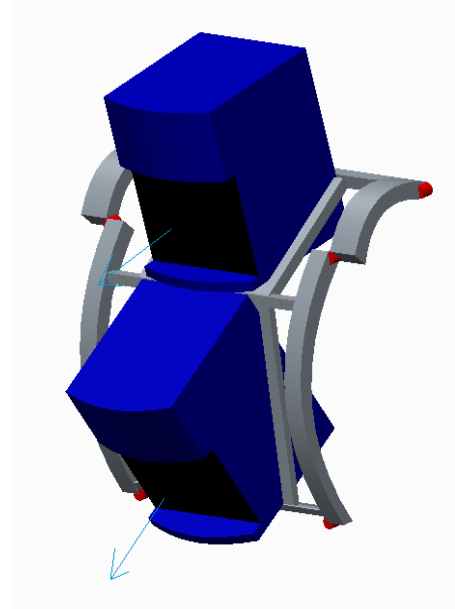

Figure 8: Trimetric view of lasers stacked on centerline

and below the laser,

preventing any heavy torque to form on the

structure due to laser weight. The angle of scanning is shown in Figure 9. The orientation allows for easier installation at the required angles.

Pros

- Centerline position allows for easier calculation and coding
- Easier implementation of hinge
- No interference from ATV components
- No interference between lasers

Cons

- Both lasers closer to ground and susceptible to environmental damage
- Additional machined components required
- Stress distributed towards the front of ATV frame

- Design Concept 3

This design includes mounting one laser in front of the ATV and the other on top of the trunk on the same centerline as shown in Figure 10. The front laser would scan the closer environment while the rear would look for objects farther ahead. This configuration will require the rear laser to be placed on an aluminum box on top of the trunk. This is to give the laser the necessary height to operate without interference. A stress analysis must be done to determine whether the trunk cover will withstand the load of the additional components. The front laser will be mounted on the frame just below the rear laser's line of sight. The front laser will also require a housing similar to the one used in Design 2 for the top laser. This will provide stability to the front while allowing for easier hinging if needed.



Figure 10: Front view, front/back configuration

Pros

- Both lasers in centerline provides easier calculation and coding
- Equal front/rear distribution reduces clutter in one area
- Front laser not inhibited by ATV components

Cons

- Rear laser requires additional components to heighten
- Trunk cover may not support the weight if the laser and additional component
- Front laser closer to ground allowing for environmental damage

- **Design Concept Selection**

The selection of a laser mount involved the use of a decision matrix with the three design concepts as shown in Table 1. This shows that the best design for our requirements is Design Concept 2, the stacked configuration. One main factor to the selection of this is its high functionality. This concept will allow the lasers to perform all the tasks we set for it. Another quality contributing to this selection is the lasers’ low interference with other components in this position. Neither laser will come in contact with the human driver, other ATV components, other sensory equipment, or the other laser. The final outlier in this concept is its ease of calculation. Since both lasers will be mounted on the centerline of the ATV, gathering and computing the data will be easier.

Table 1: SICK Laser Decision Matrix

		Design concept 1	Design concept 2	Design concept 3
	Weight			
Functionality (does it work as it should)	10	6	10	7
Simplicity (# of parts)	7.5	10	6	5
Ease of manufacture	6.5	9	6	4.5
Low cost	5	9	8	6.5
Low time to manufacture	7.5	9	7.5	7
Small amount of interfearence (parts/human)	9	4	8.5	4
Low suceptability to damage(enviroment impact or rust etc.	7	8	7	6
Ease of data calculation	4	3.5	10	9
Ease of adjustment	4	8	9	8.5
Low energy consumption	5.5	5	5	5
Lightweight	3	7	6	5
	Final score	492.5	527.25	412.25
	Max Possible	690		

- Final Concept

Our final design is illustrated in Figure 11, as shown to the right. The lasers are angled down at specific angles to scan their respective environments. This is accomplished by connecting them to plates via their bottom and back. The plates will be connected to rods that connect the left and right main bars. The main bars and connecting rods will be bolted at four points to the ATV's front chassis. The plates that balance the lasers themselves are shown in Appendix A-7. The material used for creating the mount will be Al6061. This decision was made for its low cost, strength, and ease of machinability. They will be cut using a water jet cutting tool. The components that will need additional machining will be done in one of the FAMU-FSU COE machine shops. The bolts that will be used and any other connecting equipment that may be required will be purchased through McMaster Carr.

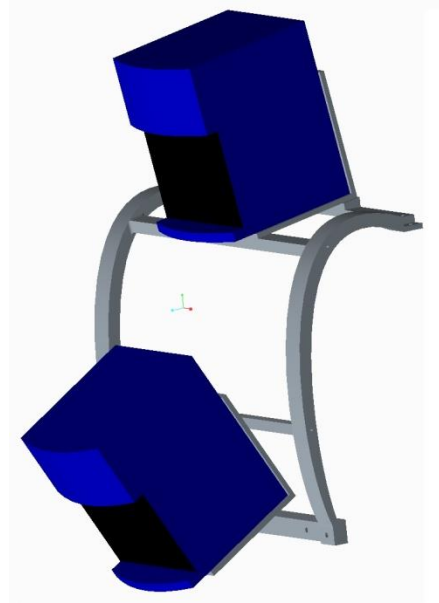

Figure 11: Finalized Stacked Configuration

The modeling for the laser mount was done in PTC Creo. A visual model along with finite element analysis was done to establish the functionality of our design. The FEA analysis was made to simulate the ATV under a slow speed collision (at 20mph). This is assumed to be a worst case scenario. The results, shown in Figure 12 below, indicate how much displacement the rods will experience and where the high stress concentration points are. It was found that the rod underneath the top laser will show the most bowing under this force. The points at which stress will be at its maximum are located at the end of the lower rod where it is connected to the main bars. This max stress was found to be 105Mpa. Al6061 has a yield strength of 241Mpa, therefore the design has a safety factor of 2.303 which is large enough to constitute its use. All of the machines drawings can be found in Appendices A-2 to A-7.

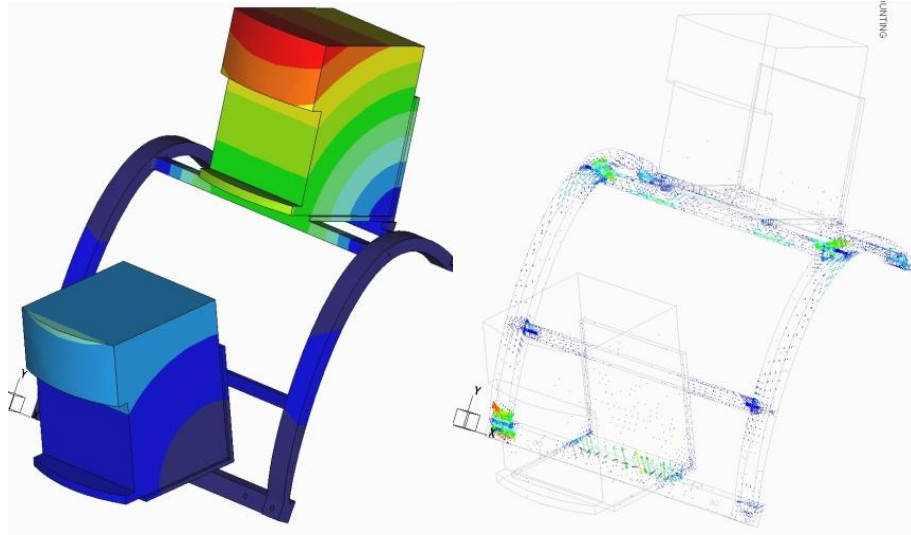

Figure 12: FEA Results indicating displacement and areas of stress concentration

- Final Design, Machining and Assembly

The final mount is illustrated in Figure 13 to the right. The design for the structural bars were modified with straight sections for simplicity. The thickness of the bars were also increased to $\frac{3}{4}$ inch for added support. The crossbar locations were changed in order to achieve the appropriate angles of scanning and fit the lasers around the front frame of the ATV.

For simplicity and time, we water jetted the structural bars instead of using the CNC machine. The crossbars were ordered in the correct cross-sectional dimensions and cut to length. The mounting plates behind the laser were modified with oblong holes to allow for axial tilting. They were redesigned to have two parts each, removing the need to bend the material. All part drawings can be found in Appendix A.



Figure 13: Final laser mount and lasers.

The structural bars were bolted to the frame using existing holes on the bottom as well as manufactured holes with M8 bolts on the upper frame. The crossbars were tapped and connected to the structural bars via M5 bolts. The plates were connected to the crossbars and lasers using M6 bolts.

- *Encoder mounting*

The encoders are an extremely important part of the sensing system of the ATV. The encoder data will be used to determine the position of the wheels and in turn the position/distance traveled by the ATV. In conjunction with a clock signal from a computer the velocity and acceleration of the ATV can be computed. The encoders were already picked out and purchased last year. The belt/pulley system to couple the encoders to the wheels was also purchased last year. Using these existing parts resulted in a limited number of possibilities for mounting locations but the belt and pulley system is clearly the best option for encoder coupling.

- **Design Concept 1**

This first design is for the left front and right front wheels. The larger pulley (green) will fit around the inner hub of the front CV axle. The encoders (yellow) will be mounted on the two upright frame tubes. The smaller pulley (red) will be mounted onto the encoder shaft. A belt will couple these two pulleys. A front and trimetric view of the subframe can be seen in Figures 13 and 14.

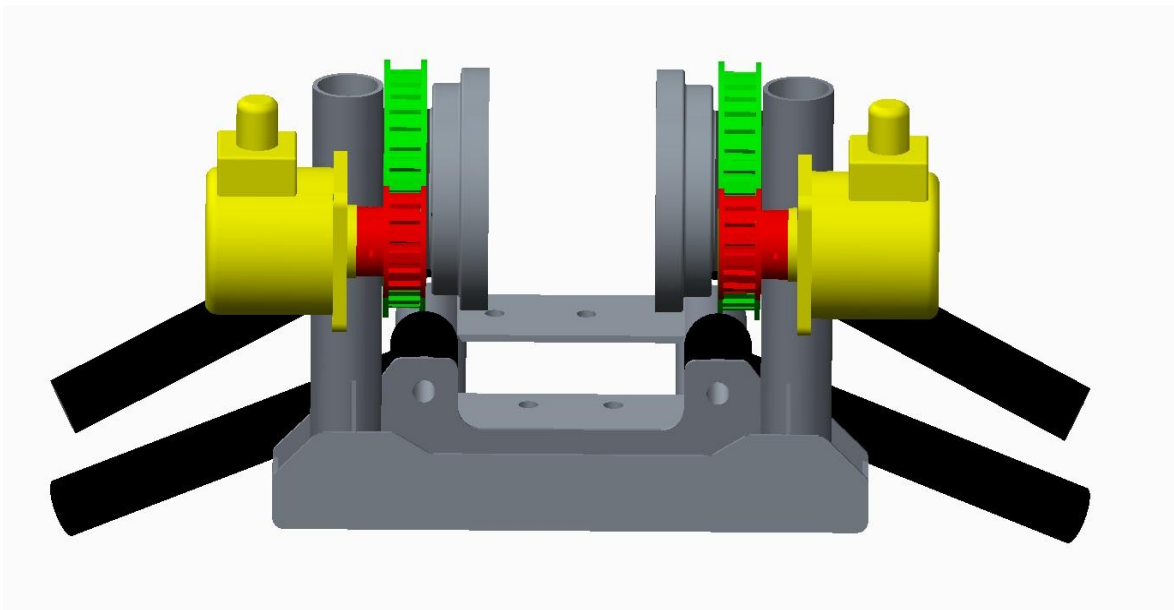

Figure 14: Front view of the front encoder mounting locations.

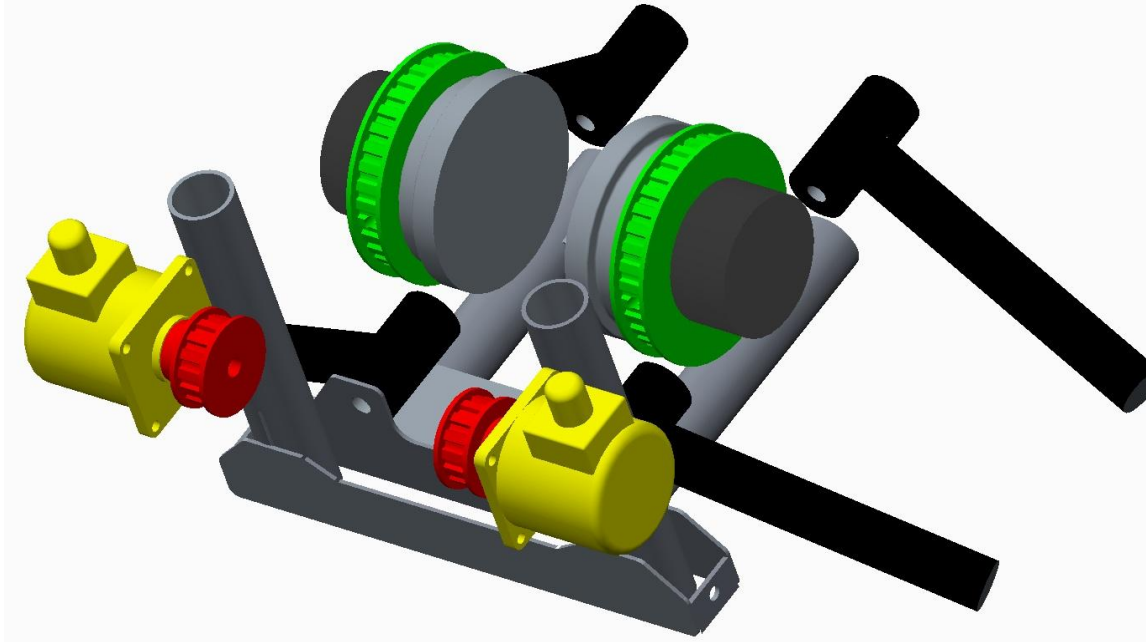

Figure 15: Trimetric view of front encoder mounting locations.

Pros

- Both encoders are in safe location
- Close proximity to tubular frame makes for simple mount manufacturing
- Location makes for easy removal / belt adjustment

Cons

- Moving belt runs very close to frame
- Moving pulleys would need to be very close to front differential, potential contact

- **Design concept 2**

This is a second option for mounting the front encoders. The larger pulley (green) will fit around the inner hub of the front CV axle furthest away from the differential. The encoders (yellow) will be mounted under the subframe. The smaller pulley (red) will be mounted onto the encoder shaft. The belt will run through the lower control arm and couple these two pulleys. A trimetric view of the encoder mounting positions can be seen in Figure 15. Since the encoders are on the underside of the ATV they are subject to damage. Figure 16 illustrates a skid plate that would protect the encoders from damage and debris.

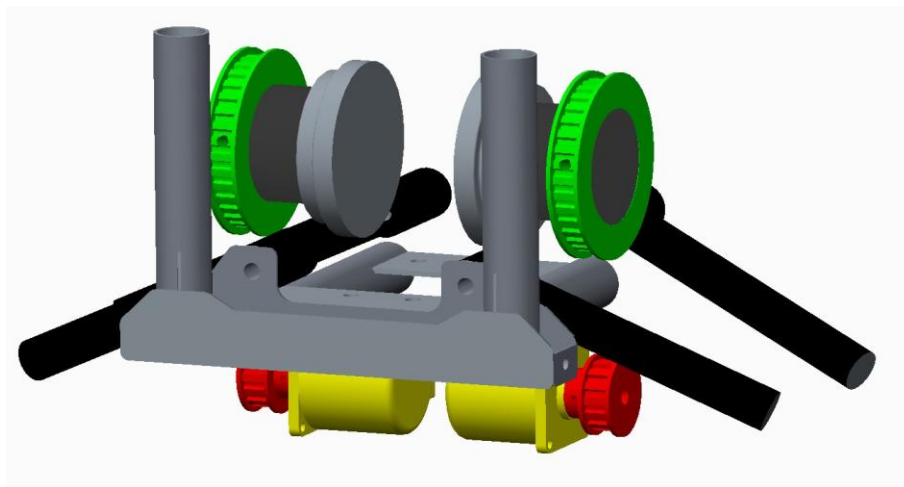

Figure 16: Trimetric view of encoders mounted under the subframe

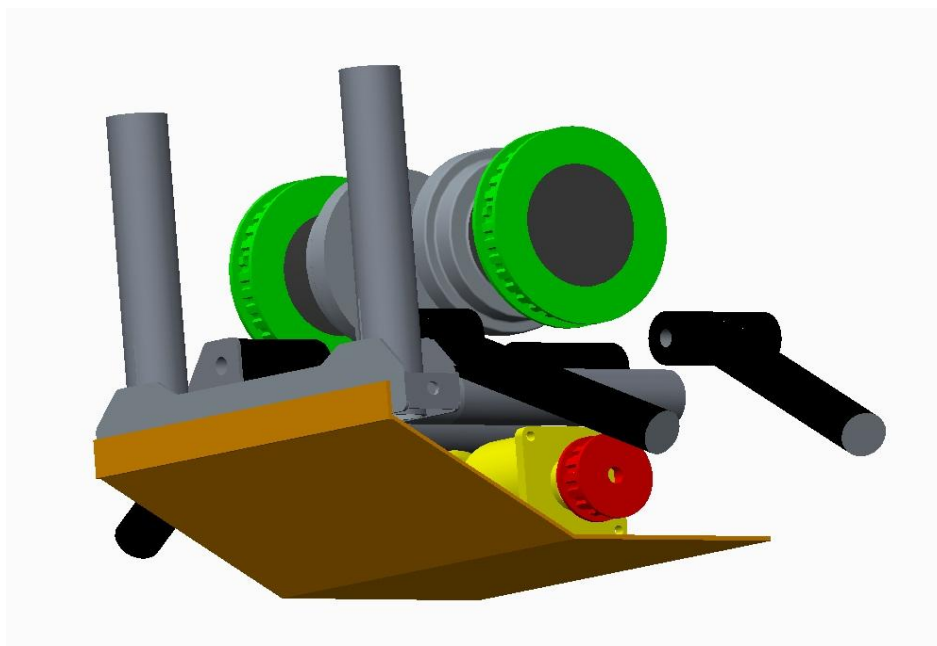

Figure 17: Added skid plate to protect encoders under the subframe

Pros

- Lower position allows for plenty of room for moving belt
- Larger pulley not close to hitting any other components
- Placement makes for simple mounting bracket manufacturing

Cons

- Must make extra part (skid plate)
- Reduces ground clearance by 2.5 inches.

- **Design Concept 3**

This Design is for the mounting orientation of the left rear and right rear encoders. With the parts supplied and the geometry of the rear subframe there was only one logical mounting solution. The larger pulley (green) will fit around the inner hub of the front CV axle furthest away from the differential. The encoders (yellow) will be mounted on top of the rear lower control arm brackets. The smaller pulley (red) will be mounted onto the encoder shaft. The belt will couple these two pulleys. Figures 17 and 18 show the rear encoder mounting solution.

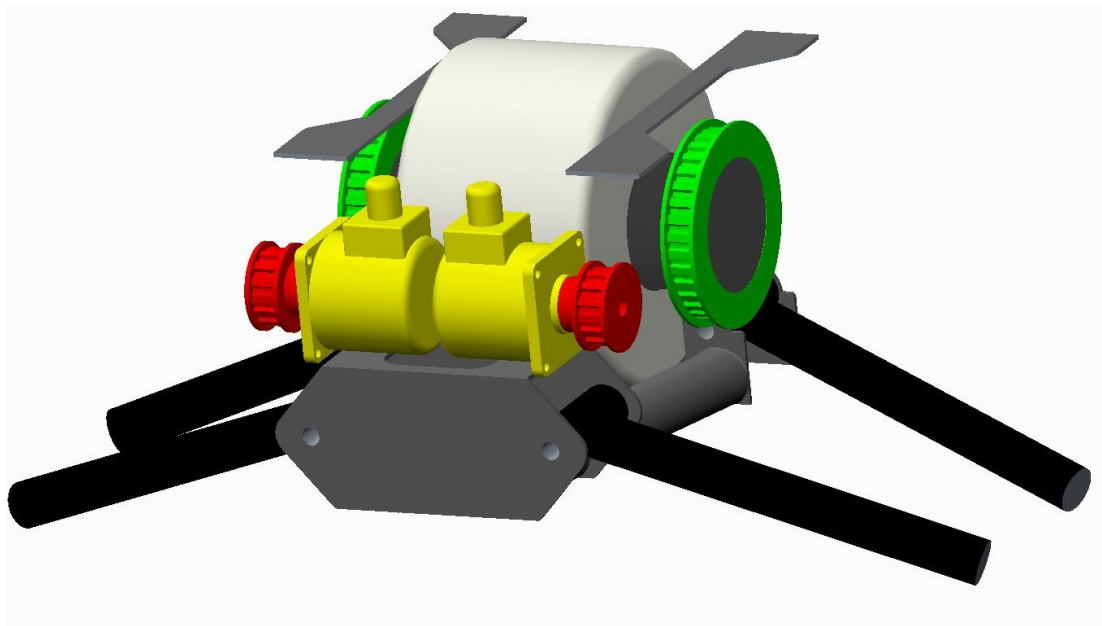

Figure 18: Trimetric view of rear encoder mounting location

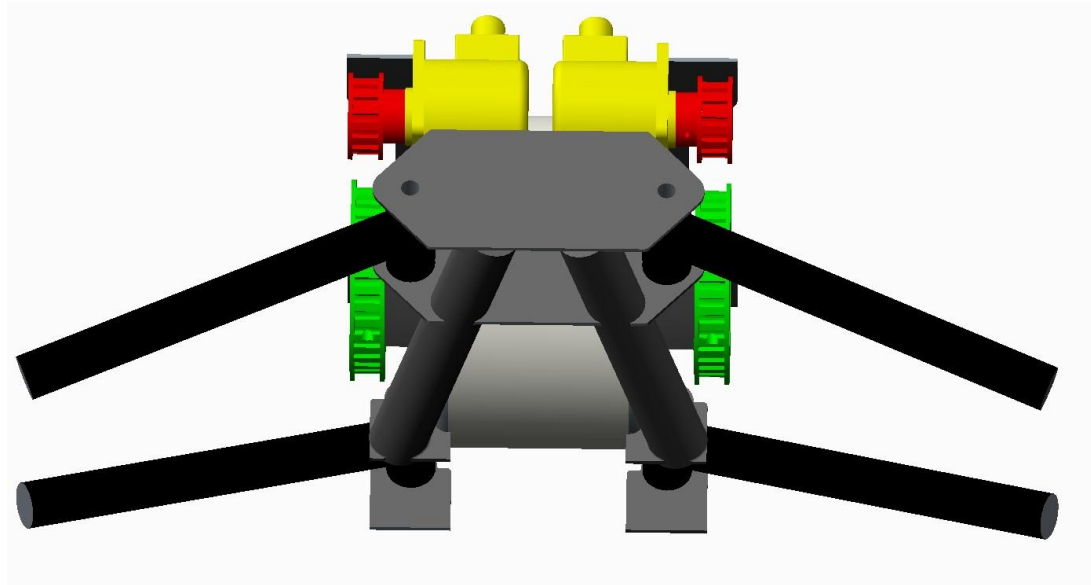

Figure 19: Bottom view of rear encoder mounting solution

Pros

- Plenty of room for belt to move without hitting any components
- Larger pulley not close to hitting any other components
- Placement makes for simple mounting bracket manufacturing
- Placement makes for easy removal / belt adjustment

Cons

- Possible debris getting kicked up into belt by tires

- **Design Concept Selection**

The final design for the front encoder mounting was done using a decision matrix as seen in Table 2 below.

Table 2: Decision Matrix for Encoders

		Design concept 1	Design concept 2
	Weight		
Functionality (does it work as it should)	10	7	9
Simplicity (# of parts)	7.5	9	8
Ease of manufacture	6.5	9.5	9
Low cost	5	10	9
Low time to manufacture	7.5	9	8.5
Small amount of interfearence (parts/human)	9	4	9
Low suceptability to damage(enviroment impact or rust etc..)	7	7	5.5
Ease of data calculation	4	10	10
Ease of adjustment	4	7.5	7.5
Low energy consumption	5.5	10	10
Lightweight	3	8	7
	Final score	550.75	582.75
	Max Possib	690	

For the rear encoder mount no decision was necessary because there was only one possible configuration that was apparent. For the front mount, design concept 2, encoders mounted under the frame, was the winning choice because it had the best functionality and least amount of interference. The belts linking the pulleys are free from any obstruction and will allow the encoders to accurately sense the position of the wheels. Both of these categories were weighted high and led to design 2 scoring the highest. For all of the concept selections functionality was usually the deciding factor because it is not practical to follow through with a design that will not function properly.

- **Final Concept**

The final concept consists of one single piece of water jet, 1/8 inch thick 6061 aluminum as seen in Figure 19. The mount will be bent along perforations made by the water jet to ensure the bend in the material is straight. Then the two encoders will be attached on the inside of the mount with M5 bolts and locknuts. To keep the mount from flexing under any load there will be two 8mm diameter Al6061 aluminum rods attaching the bottom of the mounts to each side. Clearance holes will be cut for the encoder shafts to pass through along with four mounting holes for each sensor. All of these holes will be oblong to allow tensioning and adjustment of the belt by shifting the encoders to increase the relative distance

between the encoder pulley and the driveshaft pulley. This mount will be bolted or welded to underside of the frame.

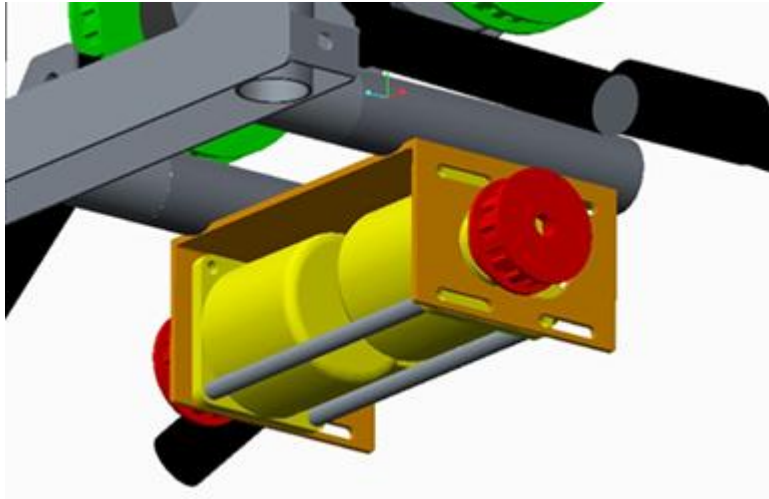

Figure 20: Final concept for front encoder mounting

To prove the structural stability of this design, FEM analysis was done in CREO Parametric. The manufacturer of the encoders has set an absolute maximum force that can be applied to the encoder shafts. This value of 80 lbf was applied to the ends of each shaft for the FEM analysis. The shaft displacement and stress distribution can be seen in Figure 20.

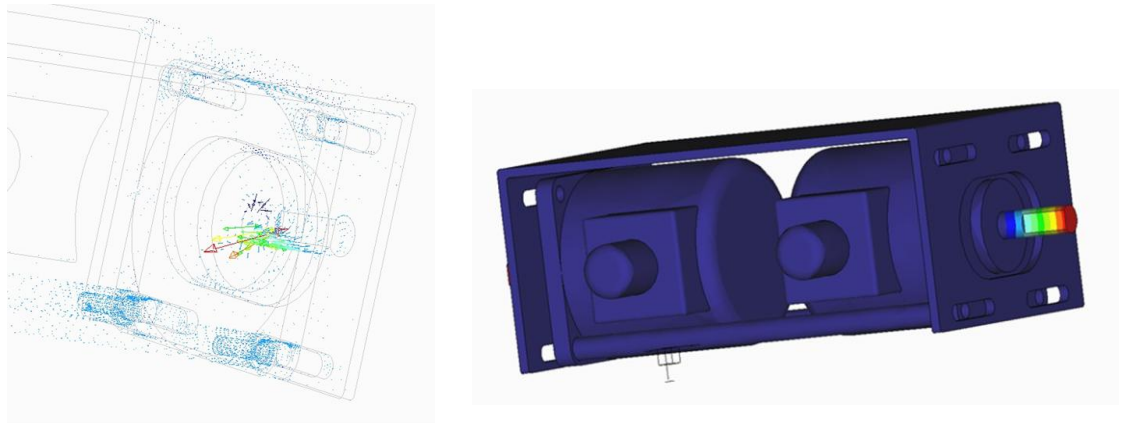

Figure 21: Left: Displacement of encoder shafts. Right: stress concentrations at base of shaft

As expected, the main stress concentrations are located at the base of the shaft. The max stress seen at the shaft base was 80 MPa. The yield strength of stainless steel is 200 MPa, resulting in a factor of safety of 2.49. Since the encoder shafts were the smallest part and took most of the load, the mount did not see very high stresses at all. The analysis also showed that there were higher levels of stress located at the bolt holes. In Figure 21, the rear mount location is shown. Conveniently the same mount for the front also fits in the rear. This will reduce manufacturing time and design time. The material used for these two mounts will be obtained from scrap 6061 aluminum at the machine shop to save on cost. All of the machine drawings with dimensions can be found in Appendix B-2 and B-3.

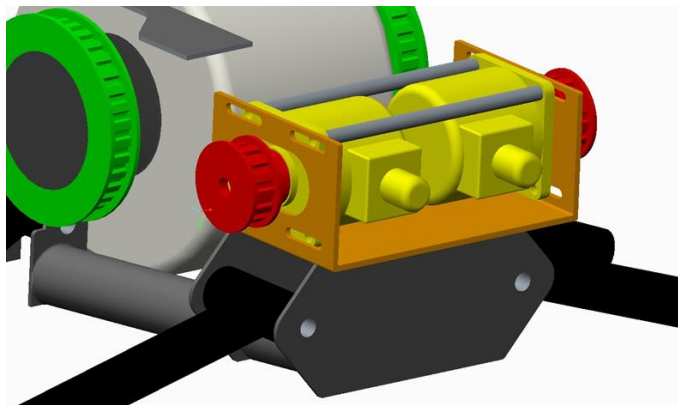

Figure 22: Final design for rear encoder mounting

- **Final Design, Machining and Assembly**

To properly space the encoders, the size of the front mount was widened and two other bars installed to provide additional support, as shown in Figure 23. Bolt holes for M5 bolts were also added in the appropriate areas to connect the mounts to the frame. All other design components were as previously stated.

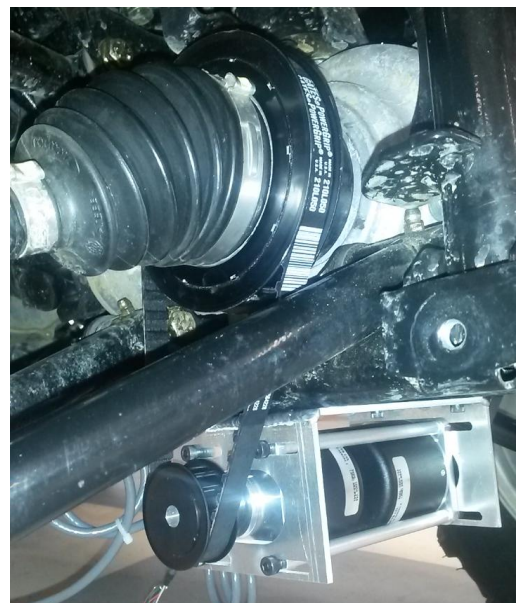

Figure 23: Final mounting for rear encoder mounting



Figure 24: Final mounting for front encoder mounting

are shown in Figures 23 and 24, respectively. All part drawings can be found in Appendix B.

The mounts were also made using the waterjet for simplicity. They were bent along the perforations to create the desired shape. Due to bending, stress cracks were formed along the length of the bend. To strengthen this area, the cracks were welded on the outer edges. Cylindrical rods were ordered to size and cut to length. The ends were then drilled and tapped. These connected to the mount plate via M5 bolts. The final mounts for the rear and front encoders

- *Steering Motor Mounting*

The steering motor that was installed last year was under powered and needs to be replaced with one that can provide more torque. The mounting design in place now is an aluminum frame bolted to the frame of the ATV just in front of the steering column. The motor and steering column are mechanically coupled by a heavy duty chain. Since the mounting design is already in place and works very well there is no need to modify the current design heavily. There is only a need to install the new motor in place of the old one.

- **Design concept 1**

This design directly places the new motor in the same location of the old motor. There only needs to be two modifications to the current mounting system. The first modification is to machine a bigger diameter hole in the motor gear to accommodate the larger output shaft of the motor. After initial measurements it was found that the current mount is wide enough to fit the new motor with only recreating one piece of the aluminum mount. This plate (red) modification can be seen in Figure 22. A larger counter-bore will be machined and the mounting holes are rotated 45 degrees to be able to fit within the width constraints of the previous mount.

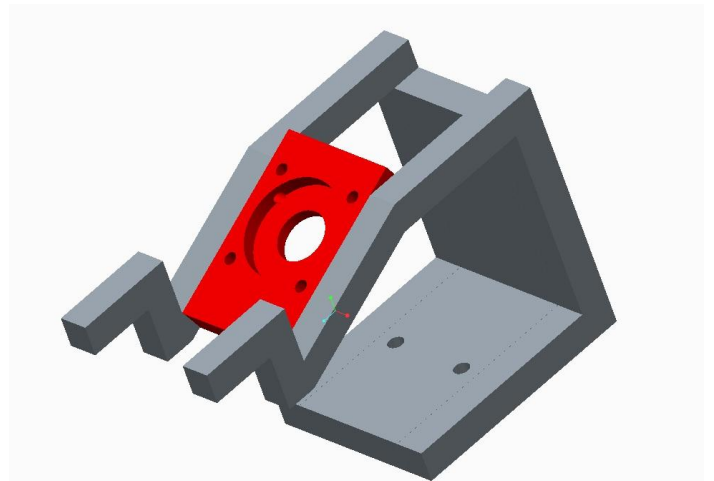

Figure 25: Modified aluminum motor mount

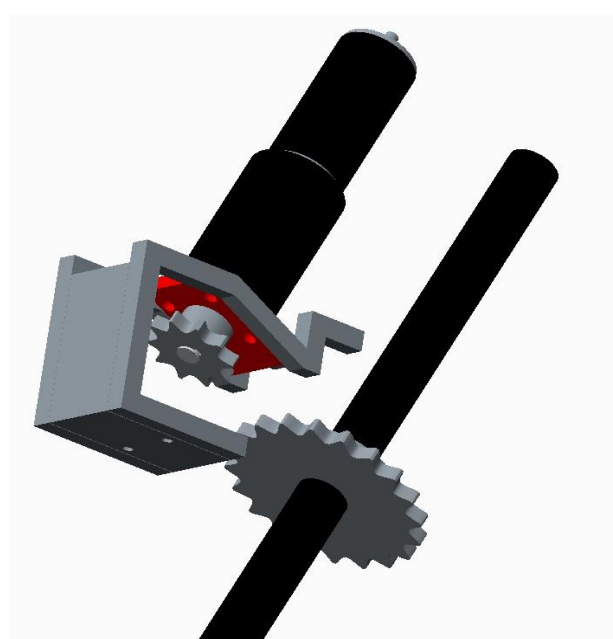

Figure 26: Full system representation with larger motor installed on new mount

Pros

- Very simple design modification
- Utilizes existing mounts
- Can be plugged directly into existing wired connections
- Minimal fabrication and material costs

Cons

- Larger motor will cause larger bending moment and stress in the mount.

- **Design Concept Selection**

For this design there was no selection process. This was due to the fact that there was already a motor mount and drive system in place for the steering. Since the current design worked well but only needed a stronger motor it was clear that only a slight modification should be made to the motor plate to accommodate the larger motor.

- Final Concept

The new motor mount has all of the same dimensions and bolt holes as the old one with exceptions for the depth and diameter of the motor recess and the bolt spacing to the motor face. Also, the edges of the mount was rounded to reduce stress concentrations and overall weight. The mount will be bolted directly in place of the old mount using the existing holes and bolts in the mount. The machine drawing for this part can be found in Appendix E-3. To prove the structural stability of the new mount, it was rendered in CREO Parametric and an FEM analysis was performed. To perform a correct analysis of this part the worst case scenario was used. The worst case scenario for maximum force applied to the mount would be if the motor was given max voltage and current when the motor is not moving due to external forces such as the steering reaching the end of its travel. The torque applied by the motor at this condition is called stall torque. With a gear ratio of 100:1 this stall torque value is 892 Nm. This torque was then applied to the bolt holes to the motor and the results can be seen below in Figure 24.

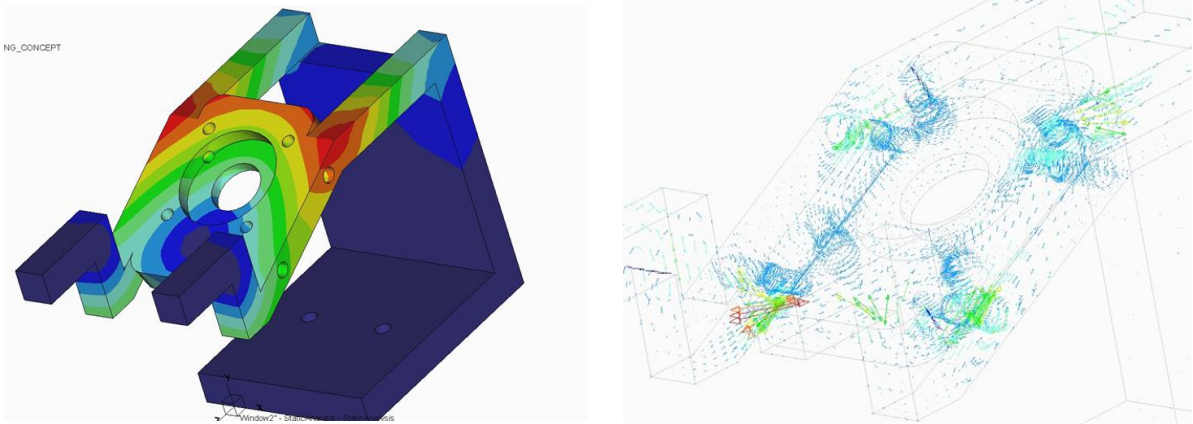

Figure 27: Left: Displacement of motor mount under load. Right: Stress concentrations of motor mount under load

The mount is made from 6061 aluminum with a yield strength of 240 MPa. The max stress seen in the simulation was 95 MPa, resulting in a factor of safety of 2.55. A closer look at the mount in Figure 25 shows that the stress concentrations are located at the bolt holes where the torque was applied. The motor mount is one of the few parts that will need to be water jet and machined using a CNC.

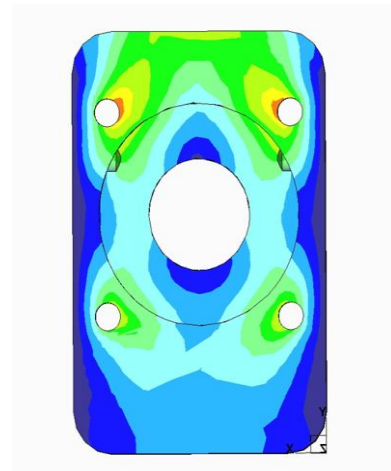

Figure 28: Stress concentrations near the bolt holes in the motor mount

- Final Design, Machining and Assembly

The steering motor mount was altered by removing the counter sinks for simplicity. The edges were also rounded for safety and to decrease stress concentrations. All other specifications were the same as stated above. The old gear was also cut to fit the diameter of the new motor and the key was increased to 5mm. The holes that mounted to the preexisting frame are 3/8 inch. The machine drawings for the Motor mount and the new sprocket can be found in Appendix E.

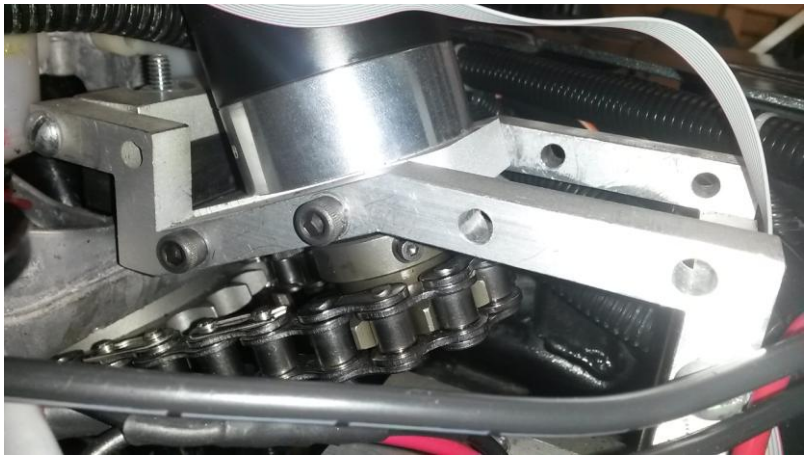

Figure 29: Final mounting of Steering motor and gear

- *GPS Mounting*

The ProPak-G2 plus GPS will serve as an ad-hoc network between the Toughbook running ROS and the single board computer running QNX while also receiving and transmitting location data for waypoint navigation. This requires the GPS and receiver to be mounted in a place where the data will not interfere with other sensors and the environmental danger is a minimum. The three designs that were generated all accomplish these tasks. Both items have low enough weight to allow mounting on the body as compared to the frame. This gives us many location points to mount including the hood and trunk. Another consideration is that the wire between the GPS and the receiver is short (about 12 inches). The GPS and receiver cannot be mounted farther apart than this distance on the ATV. The receiver will also be connected to a 12 inch pipe which allows us for easier mounting. This pipe has no effect on the transmittance of data.

- **Design Concept 1**

The first design includes mounting the GPS and receiver on the front hood of the ATV as shown in Figures 26 and 27. The GPS will be mounted on the left or right side where there are fewer indentations. This provides a flat, easily-accessible surface for mounting. The pipe the receiver is connected to will be mounted in one of the holes on the hood. These holes are close to the diameter size of the pipe but will need further stabilization through an aluminum pipe at its ground. This position is open to the environment and should be taken to account in the decision making process.

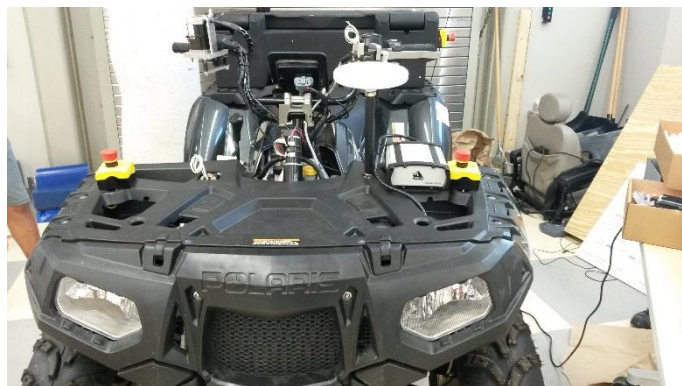

Figure 30: Left side configuration



Figure 31: Right side configuration

The receiver or GPS (depending on the orientation) will also be in close proximity to the emergency cut off switch which can be hazardous.

Pros

- Easily accessible
- Simple to install

Cons

- Receiver stability is low due to one ground point
- GPS open to environment
- Items close to emergency cut-off switch

- Design Concept 2

The next design includes mounting the GPS on the cover of the trunk as shown in Figure 28. The cover of the trunk has a box-like shape with a hollow inside. Its thickness at most points is about 4 inches. At some points, however, the thickness decreases to about 1 inch. Such a location is where the GPS will be mounted. This position prevents the GPS from coming in contact with other items inside the trunk. The receiver can be mounted to the left of the GPS, above the trunk cover. The pipe the receiver is connected to will be placed inside the cover. A hole will be drilled where the lower end of the pipe is located in Figure 29. This is in-line with the hole located to the left of the GPS in Figure 28. The pipe will then sit inside the cover of the trunk and have two ground points to provide stability. An aluminum plate will also be positioned on the lower end on the inside of the truck cover. This will ground the pipe and provide a more stable environment for the receiver.

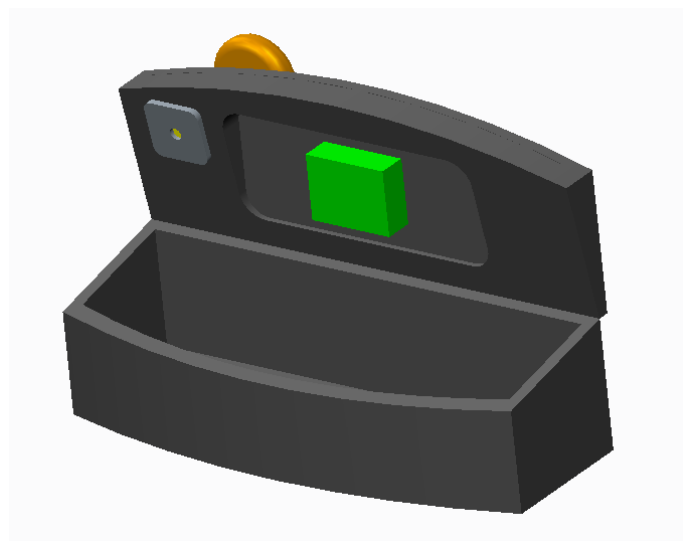

Figure 32: Trimetric view of trunk and GPS receiver



Figure 33: Top View of GPS antenna

Pros

- Mounted inside trunk provides protection
- Receiver is more stable than front configuration
- Easily accessible
- Reduces crowding in front of ATV

Cons

- Aluminum plate required for receiver stability
- GPS location adds another heat source for the trunk

- Design Concept Selection

Our GPS selection involved the same decision matrix previously used, as shown in Table 3. The two design concepts were analyzed and we found that Design Concept 2, the trunk mount, was the most suitable for our requirements. A few main components of this design that led to this decision are its small interference and low susceptibility to damage. The GPS will be encased in a truck so interference with sensory equipment or the person riding the ATV will be zero. The Antenna will also be located in a place where there are no other sensors or people. The GPS will also be heavily protected from the environment since it is enclosed in the trunk. The antenna will be more susceptible to very low hanging trees since it will be located at the highest part of the ATV. We found that this will be acceptable though because the antenna will only protrude 6 inches from the trunk lid.

Table 3: GPS Decision Matrix

	Weight	Design concept 1	Design concept 2
Functionality (does it work as it should)	10	10	10
Simplicity (# of parts)	7.5	9	8
Ease of manufacture	6.5	8.5	8
Low cost	5	9	8.5
Low time to manufacture	7.5	9	8.5
Small amount of interfearence (parts/human)	9	6.5	8.5
Low suceptability to damage(enviroment impact or rust etc.	7	7	8
Ease of data calculation	4	10	10
Ease of adjustment	4	9	8
Low energy consumption	5.5	10	10
Lightweight	3	9	8.5
	Final score	600.75	603.25
	Max Possible	690	

- Final Concept

Our final concept is illustrated to the right in Figure 30. No major changes were made to the design in Concept 2. The GPS will be mounted using four nuts and bolts on the outer corners. The mounting points are already located on the GPS itself. The antenna will still be mounted through the trunk lid and have the aluminum plate at the base of the lid for added stability. This plate, shown in Appendix D-2, will also be mounted using four nuts and bolts on the outer corners. The antenna itself will screw into the plate at the base. The plate will be made of Al6061 for its low cost and ease of manufacturability and it will be cut either using a water jet or in one of the FAMU-FSU COE Machine Shops. The nuts and bolts required will be ordered through McMaster-Carr.

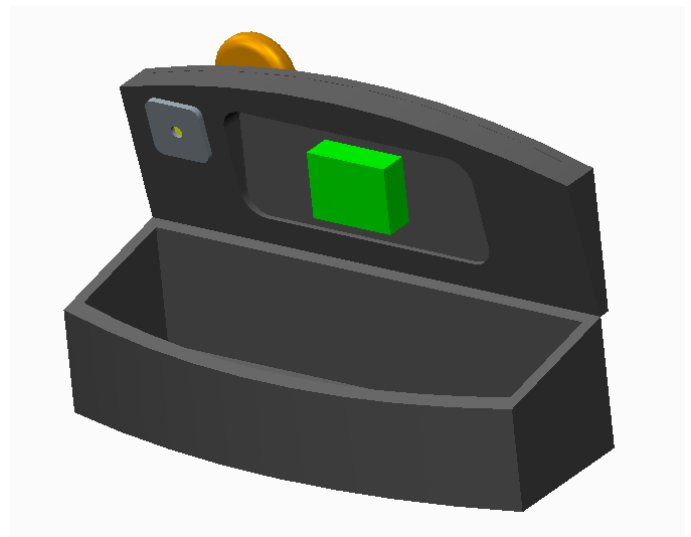

Figure 34: Finalized GPS Mounting

The modeling done for the GPS and antenna placement was done in PTC Creo. We did not perform stress analysis on the components because we assume the light weight of both the GPS and antenna will not cause any structural failure of the trunk lid.

- Final Design, Machining and Assembly

The final design for the mounting of the GPS has not changed much other than the fact that the GPS, IMU, antenna, and Router were all mounted on the trunk lid using one single mount that spans the entire underside of the lid as seen in Figure 35. This has drastically simplified the design and has changed the location of the IMU. The mounting holes for both the GPS and IMU were cut to allow for adjustment for the best possible fit in the curved surface of the lid.

The mounting plate was waterjet from 1/8 inch aluminum sheet. The GPS and IMU mounting holes were cut to accommodate M3 bolts, and the trunk mounting holes were cut for M5 bolts. The trunk lid was then drilled and cut to fit all of the components. The support rods for the antenna and router both protrude out of the top of the trunk lid. The trunk needs to still be water tight, so the gaps between the holes and the support rods were filled with waterproof RTV silicon. The power and data wires to the components are routed through the structural holes cut into the mount as seen in Figure 35. The machine drawings for the GPS/IMU mount can be found in Appendix D.



Figure 35: Final mounting of lid plate for GPS, IMU, Router and Antenna

- *Heat Dissipation*

One problem that arose with last year's project was that all of the added electrical components that were installed in the rear trunk were producing excessive heat. This caused concern of overheating and possible damage to these expensive components. The trunk also serves as protection of these components from water. The excess heat must be removed from the system without compromising the components protection from water damage. The estimated amount of heat energy added from all of the components is ~64 W. As for the level of protection from water that should be maintained, the trunk should remain protected from rain and splashes of water but it is not expected that the ATV would be submerged since it is not operable under water as well.

- **Design Concept 1**

A simple but effective way of removing heat from a system is by natural convection. This entails perforating ventilation slits into the trunk while keeping the electrical components protected from water. The design in Figure 31 shows how this could be done. The best placement for these slits would be on the front and rear of trunk and not on the bottom or top. Slits on the top or bottom would leave the electrical components susceptible to water. To help protect the contents from water, panels will be placed around the slits. The slits would also allow cooler air from the environment to flow into the trunk and assist with cooling the components.

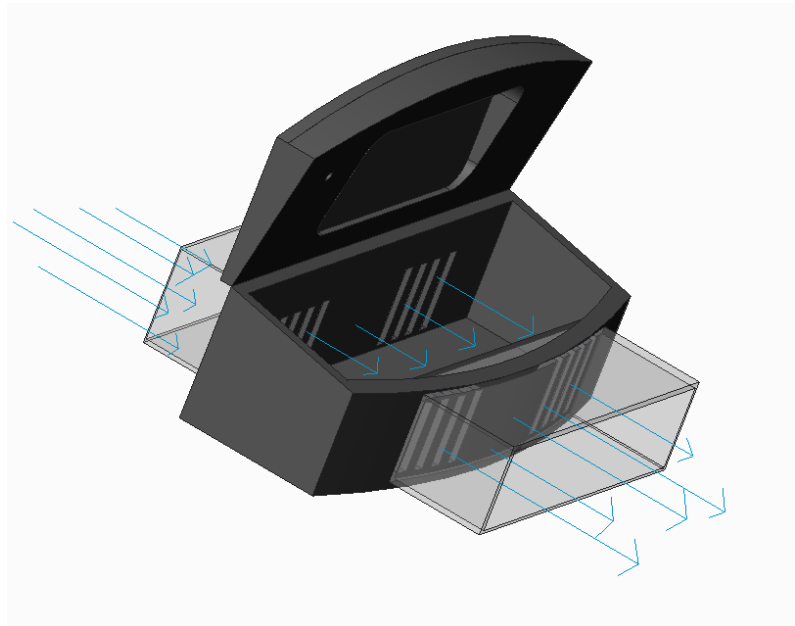

Figure 36: Trimetric view of trunk with natural convection cooling slits and protective water barrier

Pros

- Inexpensive
- Simple
- Consumes no extra power

Cons

- May not remove enough heat
- May allow entry of debris

- Design Concept 2

This design utilizes forced convection from fans that will be mounted into the walls of the trunk. This design has two fans, one located on the front left and one fan on the rear right.

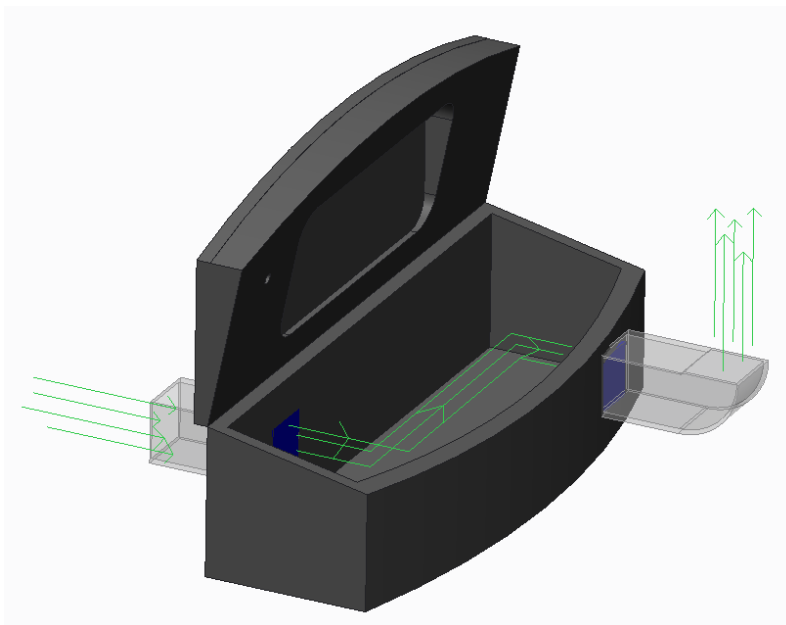

The fan in the front sucks in outside air and the fan in the back pushes air out of the trunk. This would create a good flow of air through the trunk and across the electrical components. Also to help block water from entering, panels or tubing would be placed around the fans. This is the best placement for the fans as well.

Figure 37: Trimetric view of forced convection with fans (blue)

Pros

- Relatively inexpensive
- Large heat removing capability
- Fans easily wired to power source in trunk

Cons

- Uses extra electrical power to run
- May be damaged by debris

- Design Concept 3

This design involves liquid cooling. This requires the installation of two heat exchangers, pump, expansion and storage tank, and tubing for the liquid. The first heat exchanger would be mounted outside of trunk with a fan attached to it. A pump would also be mounted onto the trunk with tubing connecting the two in a cyclic formation. The second heat exchanger would be in contact with either the air inside the trunk or in direct contact with the hot surfaces of the electronic components.

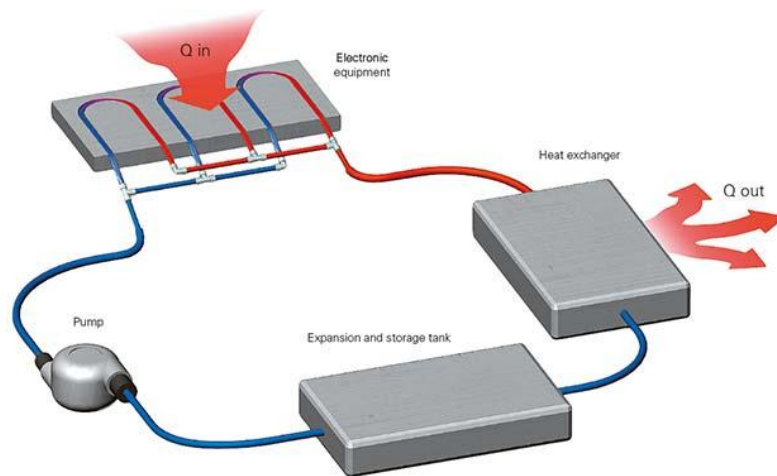

Figure 38: Liquid cooling concept diagram

Pros

- Waterproof
- Excellent heat removing capability

Cons

- Very expensive
- Uses extra electrical power to drive pump
- Very complex, lots of manufacturing

- **Design Concept Selection**

Through use of a decision matrix in Table 4, Concept 2 was the best choice for dissipating the necessary heat from the trunk of the ATV. The biggest advantage over Concept 1 was its functionality. Concept 1 would not have provided the necessary heat dissipating ability required to keep the electronics in the ATV at a safe operating temperature. Concept 3’s biggest disadvantages was the high amount of energy consumption through the use of a heat exchanger and pump, high cost, and complexity of design. Concept 2 is fairly simple and has a somewhat low cost.

Table 4: Decision matrix of heat dissipation concepts

		Design concept 1	Design concept 2	Design concept 3
	Weight			
Functionality (does it work as it should)	10	6	8	10
Simplicity (# of parts)	7.5	7	6	2
Ease of manufacture	6.5	7.5	7	3
Low cost	5	9	8	3
Low time to manufacture	7.5	8	7.5	3
Small amount of interference (parts/human)	9	6	8.5	7
Low suceptability to damage(enviroment impact or rust etc..)	7	6.5	8	9
Ease of data calculation	4	10	10	10
Ease of adjustment	4	3	5.5	6
Low energy consumption	5.5	10	8.5	4
Lightweight	3	8	9	4.5
	Final score	496.75	535	397.5
	Max Possible Score	690		

- **Final Concept**

In our analysis of the amount of heat that needed to be dissipated we made a few assumptions to simplify the problem yet keep it accurate. We first assumed a worst case scenario that the outside air temperature would be 90°F and that the internal surfaces of the ATV trunk components would be isothermal at 130°F max. Then after taking the Prandtl number, thermal conductivity, viscosity, and density at film temperature we modeled it as forced convection over a flat plate. This gave us the amount of heat that will need to be dissipated as 64.49 W. After finding the volumetric flow rate we would need to remove this much heat we were able select the proper fans. The proper fans have a 250 CFM rating. This is just enough heat removal to cover the 64W of heat generated by the internal electronics.

There are also two snorkels that need to be manufactured and added to the trunk that will allow air to flow through the trunk and still protect the inside electronics from water and debris. These snorkels will be laser cut out of abs plastic and will utilize baffles inside the tubes to reject and block water and debris.

- **Final Design, Machining and Assembly**

After realizing how difficult assembly of the snorkels with internal baffles would be, a better solution was found using a 3D printer. One snorkel was designed for both the right (air inlet) and left (air outlet) with the desired tubular shape and internal baffles. They were printed by the COE machine shop. The printing process for both snorkels took 5 days of total printing time due to the large size. The 3D printing allowed for any degree of complexity in our design. The printed snorkels can be seen in Figure 39.



Figure 39: Snorkel for weatherproofing after 3D printing



Figure 40: Final snorkel mounting and heat transfer process



3D printed parts from the COE printer are not waterproof. They are porous and will allow water to seep through them. This was fixed by painting the inner and outer surfaces of both snorkels with a rubberized waterproof coating. Once this was done, the snorkels were modified to fit the curved surface of the trunk. Due to the geometry of the trunk, the bolt holes for the fans did not line up with the ones on the snorkel. An adapter plate was then laser cut out of $\frac{1}{4}$ inch ABS plastic. M5 bolts were used to attach the assembly onto the trunk after drilling and cutting the air vent holes. To maintain the waterproof nature of the trunk, once again, RTV silicon was used as a gasket material between the snorkels and the outside of the trunk. The machine drawings for the adapter plate can be found in Appendix F.

Figure 41: Final snorkel and fan installation

- *IMU Mounting*

The Inertial Measurement Unit (IMU) is a crucial tool for autonomous vehicles. The IMU in use for this project is a 6 degree of freedom inertial system which uses 6 elements to measure linear acceleration and angular velocity. This is used to help the computer track the ATV's position. When choosing a placement for this unit on the ATV it is best to mount the IMU centrally on the vehicle for ease of data calculation and where it will encounter the least amount of vibration or damage.

- **Design Concept 1**

The first possible location to mount the IMU is inside the trunk. The benefits of this location is that it will be protected from weather elements, receive cooling if needed, will receive small amounts of vibration, and be easily connected to the computer. The drawback with this location is that it will not be centrally located on the vehicle.

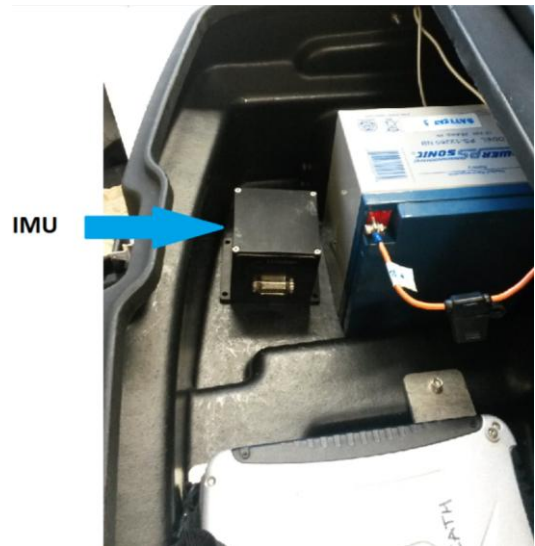

Figure 42: IMU mounting location inside trunk

- **Design Concept 2**

The second possible location for the IMU to be mounted is between the ATV's seat and handlebars. This location is beneficial in that it is located close to the center of the ATV and it will receive minimal vibrations from the ground. The drawbacks to this location is that the IMU will not be protected from weather elements and that the unit will have to be directly connected to the computer inside the trunk about three feet away. A cover will have to be put over the IMU to protect it from weather elements and also possible damage from a human driver.

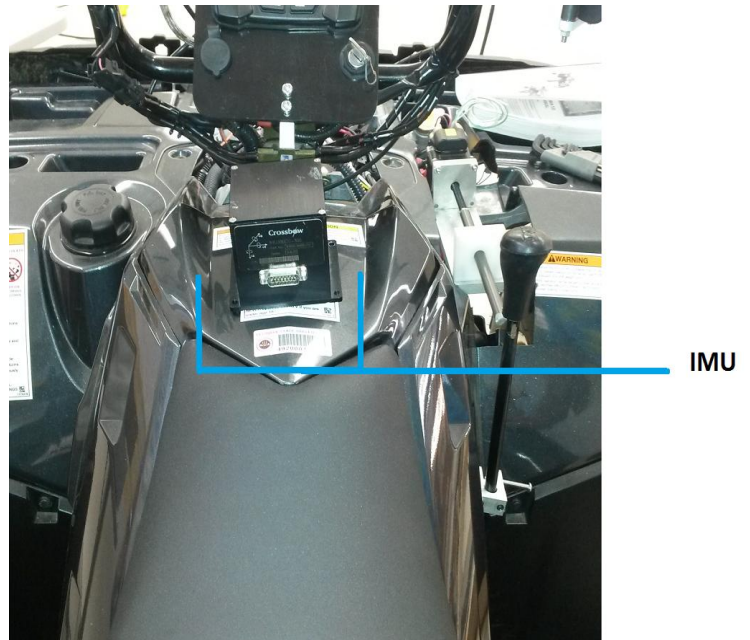

Figure 43: IMU mounting location between handlebars on the ATV's centerline

- **Design Concept 3**

The third possible location for the IMU to be mounted is on the front hood of the ATV. This is beneficial in that the IMU will be in a location easy to install and the top plastic cover serves as a protective barrier around the edges. The drawbacks to this location is that it will not be protected from weather elements, have to be directly connected about five feet back to the computer inside the trunk, will receive moderate vibration from the front wheels, and is not centrally located.

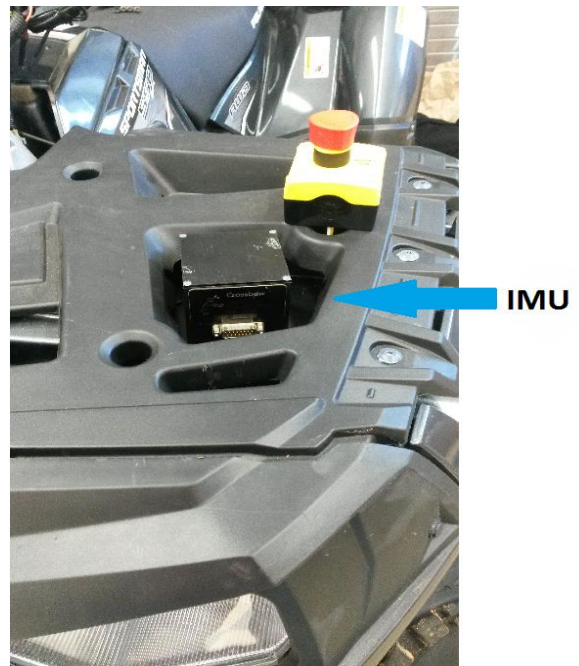

Figure 44: IMU mounting location on the hood of the ATV

- **Concept Selection**

Out of the three concepts for placement and mounting of the IMU, concept 1 received the best score from our decision matrix. In Table 5 it is clear that concept 1 had more advantages than the other two concepts. Concept 1’s biggest advantage over the other concepts was its low susceptibility to damage being located in the ATV trunk. Also concept 1 has a low cost to manufacture the mounting bracket as well as good simplicity of design.

Table 5: Decision matrix for the IMU mounting

		Design concept 1	Design concept 2	Design concept 3
	Weight			
Functionality (does it work as it should)	10	10	10	10
Simplicity (# of parts)	7.5	9.5	8.5	8.5
Ease of manufacture	6.5	10	9	9.5
Low cost	5	10	9	10
Low time to manufacture	7.5	10	8.5	9
Small amount of interfearence (parts/human)	9	7	6	8
Low suceptability to damage(enviroment impact or rust etc..)	7	10	6	8
Ease of data calculation	4	7	10	7
Ease of adjustment	4	8.5	9	8
Low energy consumption	5.5	10	10	10
Lightweight	3	10	9.5	10
	Final score	641.25	586.5	616
	Max Possib	690		

- **Final Concept**

This concept will have the IMU bolted inside of the ATV trunk where it will receive protection from water and debris. The IMU will also be in a prime location where the cable can be connected to it from the computer.

- **Final Design, Machining and Assembly**

The final design for the IMU mounting can be seen in Figure 35, under the same section as the GPS mounting. This was done because both sensors were installed using the same mount.

Programming Needs and Control

Once all of the sensors are mounted there needs to be a way of processing the sensory data and sending outputs to the actuators. This is where the 2 laptops and wireless router will help achieve this task. Below in Figure 37 is the complete system block diagram.

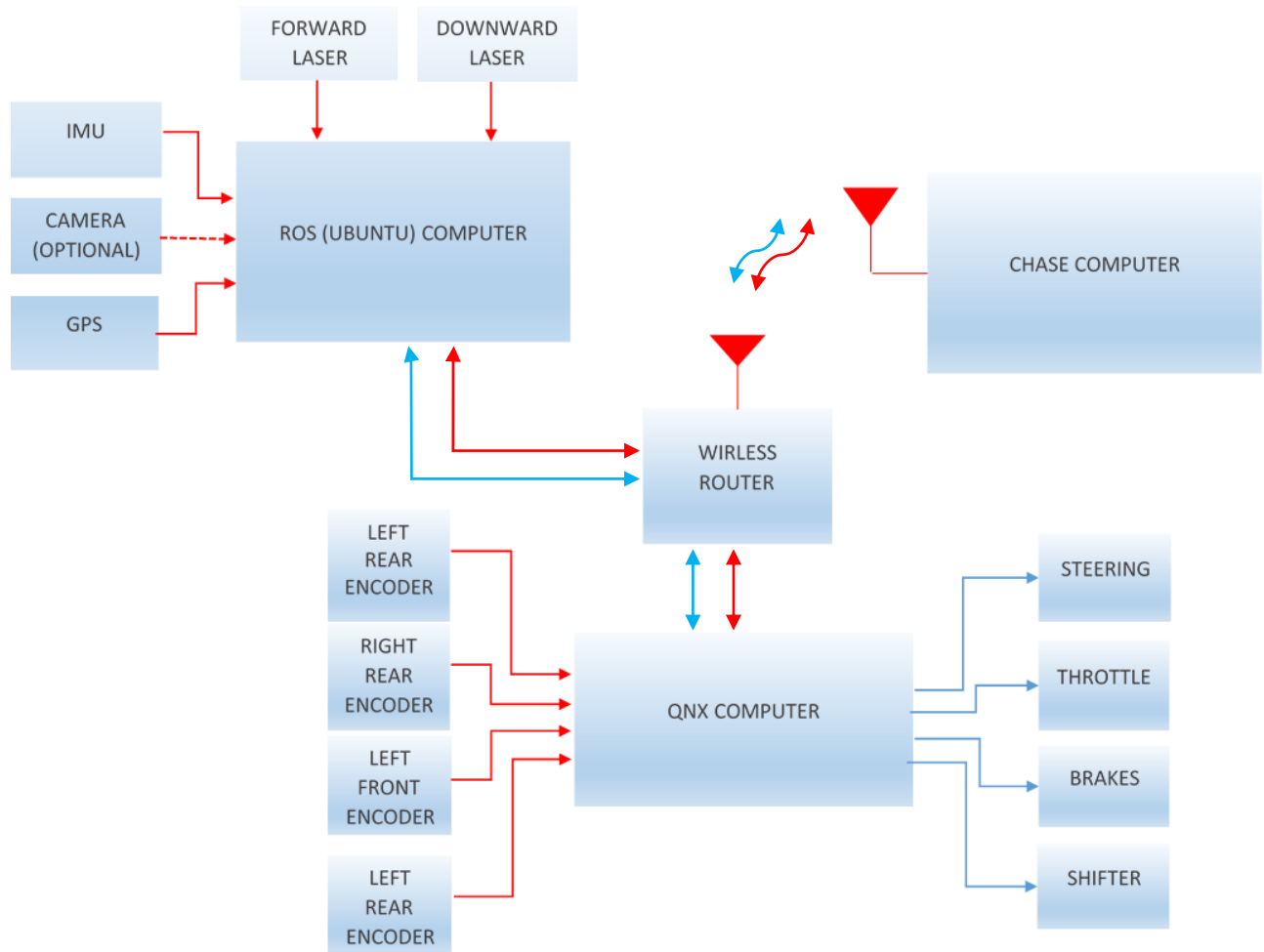

Figure 45: Full system block diagram

- Computer Coding Concept

The computer system on the ATV consists of two computers, one running Robot Operating System (ROS) and the other QNX. ROS is an open source software that helps manage hardware and contains reusable packages. ROS will be running on a laptop with Ubuntu operating system (OS), which is a Linux based OS. The C++ programming that will control the autonomous function will be running on ROS, this consists of the main program, and several functions. QNX is a real-time operating system that will be running on the other

computer on the ATV. This will receive the trajectory data from the ROS computer to control the encoders and motors.

The main program will be started by the user on the ROS system. When started it will first actuate the steering to calibrate the steering motor encoder. It will accomplish this by first turning the wheels all the way to one side until it mechanically cannot turn anymore, then turn the wheels all the way to the other side. Counting the encoder ticks will calibrate the system to identify the straight ahead position. After this the system will establish communication with all of its sensors, including the SICK laser, GPS, IMU, and camera. It will setup the protocols and keep track of the memory address of the ports for later use. The main program will then continue to run in a continuous loop awaiting instruction from the user chase computer. The user can either pick waypoint following or road following, in which the program will jump into its appropriate function. From either the waypoint or road following functions the system will output the direction and speed data which will be sent to the QNX computers to be execute. The Pseudo code for the main function is shown below.

- **Main Function Pseudo Code**

```
Main()
  Calibrate steering();

  Initialize communications to sensors();
  While(1){
    //Wait for user selection (waypoint or road following)

    IF (waypoint)
      Waypoint(s,d) - pseudo code below
    ELSE IF (road following)
      Road_following(s,d) - pseudo code below
    ELSE
      //Set stop flag
      Brake = 1;
    END IF
    Speed = s;
    Direction = d;
    Brake = stop flag;
    Shifter = forward;
  }
```

- Road Following Function Pseudo Code

```
//First sensors scans 3-5feet in front of the ATV
//Second sensors scans 15-20ft in front of the ATV
//x1 is the distance from road edge at 0 degrees(right side)
//x2 is the distance from road edge at 180 degrees (left side)
//d is the distance from an obstacle immediately in front of atv (ranged 55-125
degrees)
//y1 is the distance from the road at 60 degrees (right side)
//y2 is the distance from the road at 120 degrees (left side)
```

```
function firstsensor(s,d){
  int x1,x2,d,s,b
  IF (b<4.5feet) THEN
    Full brake to stop immediately
    Spin
  ELSE
    Do nothing
  END IF
  IF (x1=x2) THEN
    IF (s>5) THEN
      s = s
    ELSE
      s = s + 1 //increment speed
    END IF
  ELSE IF (x1<x2) THEN
    d = -2 //turn left
  ELSE IF (x1>x2) THEN
    d = 2 //turn right
  ELSE IF (x1<<x2) THEN
    d = -4
    IF (s >1) THEN
      s = s - 1
    ELSE
      s=s
    END IF
  ELSE IF (x1>>x2) THEN
    d = 4
    IF (s >1) THEN
      s = s - 1
```

```
        ELSE
            s=s
        END IF
    ELSE
    END IF
}
```

```
function secondsensor(s,d){
    int y1,y2
    IF (y1=y2) THEN
        s = s
    ELSE
        IF s < 3 THEN
            s = s
        ELSE
            s = s-1
        END IF
    END IF
}
```

```
Road_Following(s,d){
    function firstsensor(s,d);
    function secondsensor(s);
}
```

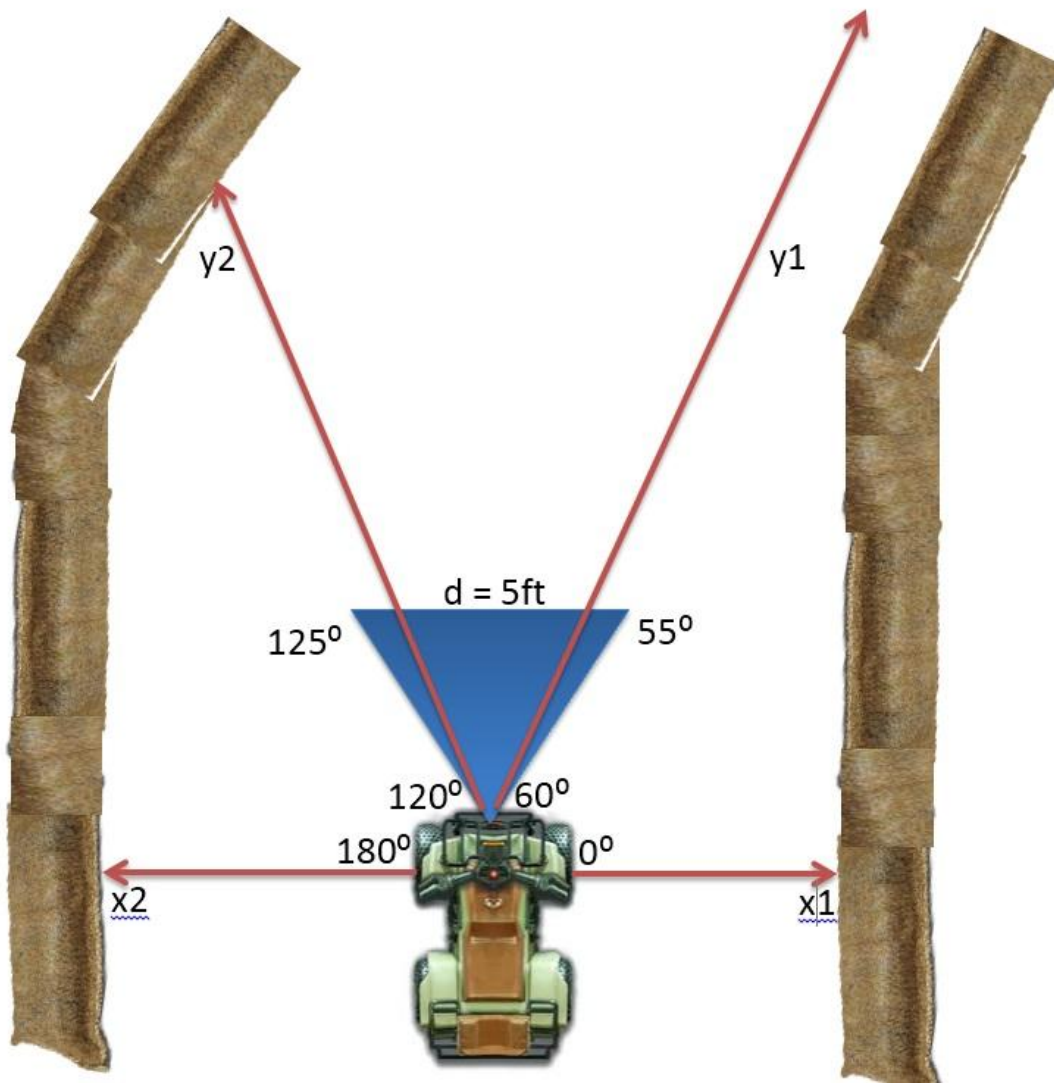

Figure 46: Logic behind sensory road following

Using ROS, the information from the SICK laser sensors are easily obtained and given by the angle and distance the object is from the sensor. This information will continuously and rapidly give the code information about three things, the distance and angle the ATV is from the sides of the road, the direction the road is heading (going straight, turning), and if there are any foreign objects in the direct route of the ATV. There have been two concepts generated in order to make the ATV autonomous with road following. Both of which involve the same pseudo code as stated above. These two concepts will be discussed below using Figure 38.

There are three continuous checks created by using IF statements that keep the ATV operating safely. These include if there are any objects directly in front of the ATV, if the

ATV is in safe operating range from the road edges, and if there are any changes of directions in the road route. The first sensor will cover the first two checks. Those two checks are if x_1 and x_2 are equal with x_1 being the distance directly to the right of the ATV and x_2 being the distance directly to the left of the ATV as well as the other check being if d has not picked up an object closer than 5 feet with d checking for an object directly in front and in the way of the ATV. The second sensor will cover the third check. This third check is to see if y_1 and y_2 are equal thus signifying that there is no turn ahead. If these checks are passed meaning that x_1 and x_2 are equal, y_1 and y_2 are equal, and there are no objects within five feet from the ATV then the ATV will start to move forward slowly. If the checks continue to be passed at true then the speed of the ATV will increase. However, if any of the checks fail, then there must be action taken by the ATV. If the sensors detect an object stationed in front of the ATV, then the ATV will immediately stop and not move until the object has been cleared. If the second check fails then the ATV will turn in order to get back in the safe zone and stay in it. Last, if the second sensor changes do to a turn in the path, then the ATV will slow its speed in order to prepare for the upcoming change in road direction.

The two different concepts involve the second and third check. The first concept will have a somewhat larger safe zone (hysteresis) for road following and allow the ATV not to slow down in a turn until the turn is immediately reached. This will allow the ATV to not have to make as many small adjustments in steering and will allow it to travel at a faster speed. This however will give more room for error in maybe hitting the sides of the road during straightaways and turns as well as have more possible obstacles in its path since the route of the ATV is wider.

The second concept will have a smaller, more precise safe zone (hysteresis) for travel in the road following, allowing it to be more controlled and have a more precise premeditated path. Also the ATV will start slowing its speed earlier when a turn in the road is indicated. Executing this concept will keep safety at the top of the line but may make the ATV run not as smoothly and will cause it to travel unnecessarily slower.

An algorithm was developed to use the data from the lower laser to find the curbs on either side of the road to locate the ATV on the road. As seen in figure X, The algorithm takes the second derivative of the data, usually called curvature, and finds the first points above the hysteresis band to the left and right of the center scan value. This technique reliably finds the start of the curbs. To account for any erroneous data, five consecutive data points for curb location will be averaged together.

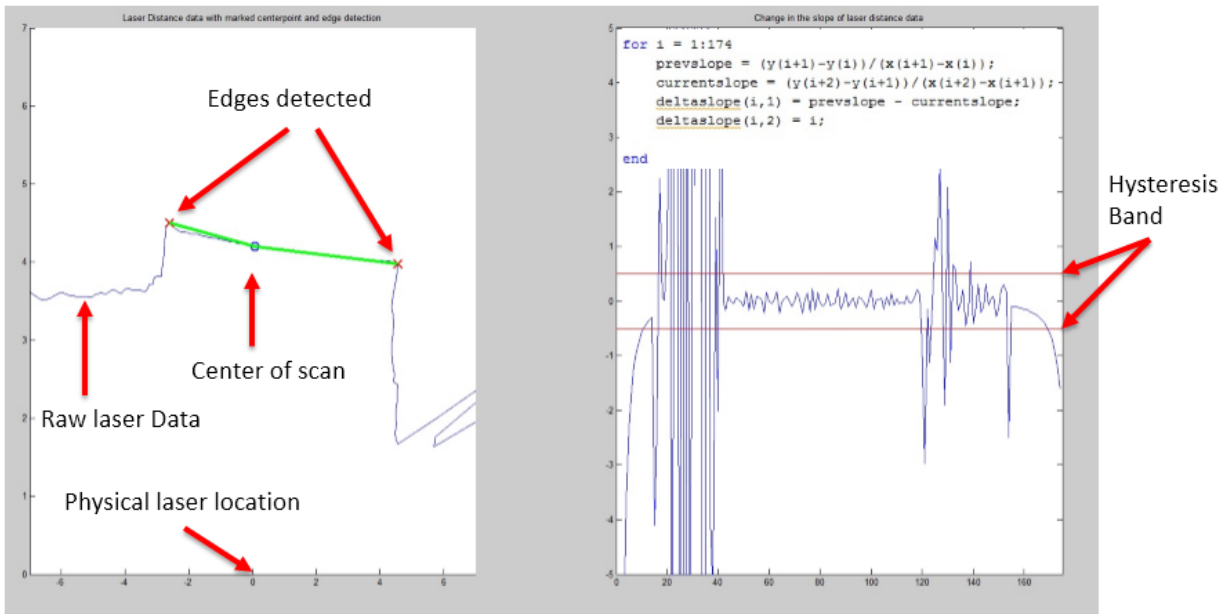

Figure 47: Laser data and second derivative graph showing edges

- Waypoint Navigation Function Pseudo Code

Basic Path Finding Algorithm:

Given a destination (x2,y2)

Record current position (x1,y1)

While (current position != destination)

 If $x_1 < x_2$

$x_1 \leftarrow x_1++$; using the encoders to determine the necessary trajectory

 else if $x_1 > x_2$

$x_1 \leftarrow x_1--$

 If $y_1 < y_2$

$y_1 \leftarrow y_1++$

 else if $y_1 > y_2$

$y_1 \leftarrow y_1--$

As an introductory project objective, this basic algorithm would be advantageous in determining the functionality of the GPS system and its integration with the network of the ATV. The user will give the ATV a destination and the ATV will incrementally alter its position to match the coordinates of its destination. The program can also be integrated with the simple object detection function that will be implemented so that the ATV will know to stop whenever it detects an insurmountable object.

The advantage of the design is its simplicity in finding a path to the objects destination. However, the design only prepares for one destination and does not determine the most efficient path of arrival. For instance, if the distance needed to travel in the X direction is larger than the distance in the Y, the ATV will travel in a diagonal direction until its Y distance is met. Afterwards, the ATV will then move in a horizontal direction until it arrives to its destination. The disadvantage lies in that instead of traveling directly to the destination, the ATV could take a two path motion as shown in the figure below where the circle indicates the destination.

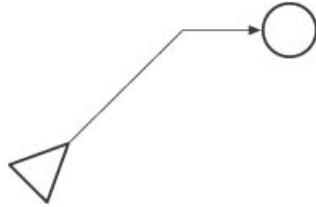

Figure 48: Basic path finding

One solution that is being explored is the Bresenham line algorithm which is used in computer science to draw a straight line on a square grid. It would be helpful due to the fact that GPS locations are based on a high resolution coordinate system similar to that of a computer. The left figure is an illustration of Bresenham's line algorithm and the figure on the right is an illustration of how it can correct the flaw of the basic path finding algorithm.

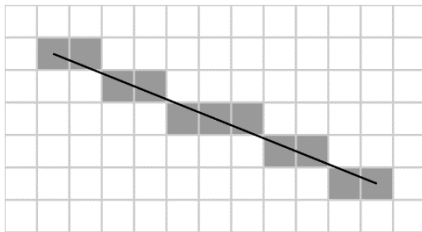

Figure 49: Bresenham's line algorithm

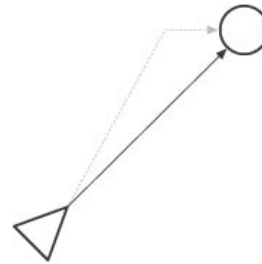

Figure 50: Application of Bresenham's line algorithm

For testing purposes, it would be ideal to test this design in an open field that is void of any major obstacles, yet large enough for the system to detect a distinct starting position and destination, relative to the precision of the GPS system.

The next plan of action will be to explore a way to help the ATV determine a path to its destination more efficiently. Ideally, the ATV should be able to determine where it is starting from and where it is going, without any input from the user at any time during the program's execution.

Waypoint Navigation Design

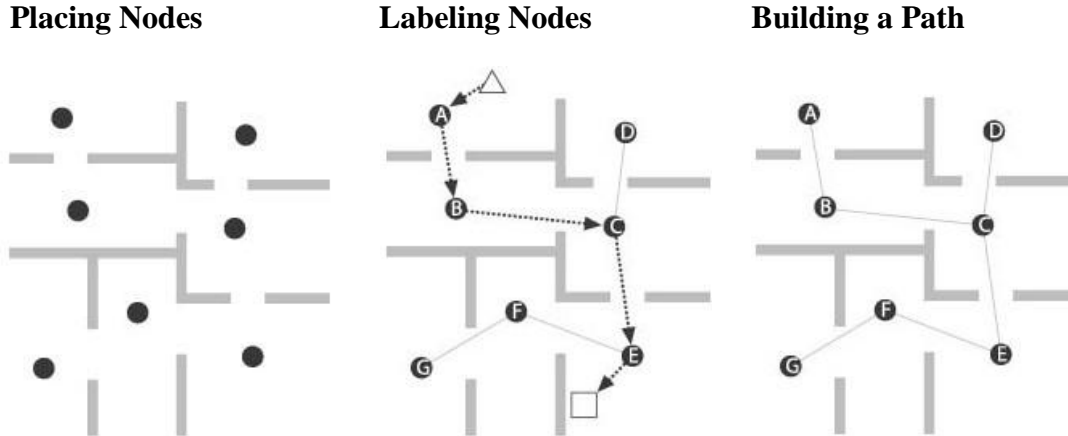

Figure 51: Placing, labeling nodes and building a path

		<i>End</i>						
		A	B	C	D	E	F	G
<i>Start</i>	A	—	B	B	B	B	B	B
	B	A	—	C	C	C	C	C
	C	B	B	—	D	E	E	E
	D	C	C	C	—	C	C	C
	E	C	C	C	C	—	F	F
	F	E	E	E	E	E	—	G
	G	F	F	F	F	F	F	—

b. From F to D: $F \rightarrow E \rightarrow D$

Figure 52: Completed node table

Functionality

1. Given GPS mapping of the terrain, the user will strategically place nodes on map such that one will always be in the “line of sight” of at least one other node
2. The nodes will be labeled in order of nodes that are most accessible (or closest to each other)
3. Depending on the beginning node, a node table will be completed to help determine the best path to the destination. Examples:
 - a. From A to G: $A \rightarrow B \rightarrow C \rightarrow E \rightarrow G$

This design will serve as a step up from the basic path finding algorithm described above. Instead of the user sending a single destination coordinate to the system for each, we can use the waypoint navigation design to set up nodes around a map, with one node being the “home” node. Using the basic path finding algorithm as a basis function, we can create a program that causes the ATV to first find the nearest node, regardless of its current position, and use the node table to find its way “home” from the node that it started from. The advantage of this waypoint navigation is that the ATV will not need step by step coordinate input from the user in order to find out how to get home.

The GPS was tested by wiring it into a car and driving around the FSU COE campus while logging data points. These GPS locations were then plotted over a satellite image to verify that the data was correct and accurate as seen in Figure X.



Figure 53: GPS commercial vehicle testing

Design for Manufacturing, Reliability, and Cost

This project involves a prototype that will be used for personal research and not undergo mass production. However, it is important to determine the manufacturability, reliability and economics of the mounts as these concepts can be industrialized.

Many of our sensor mounting designs were changed for simplicity and easy of manufacture. It was decided to use metric sized holes and bolts where possible. Most of the mounts were cut using the water jet in the machine shop of the FAMU-FSU College of Engineering. This decreased machine time and allowed for the possibility of automation in an industrial setting. The bends, taps, welds, sanding and some drilled holes were done manually but can also be automated with the proper equipment. This also removes the need for physical part drawings since the water jet uses the data from a .dxf file. Dimensions of plates, rods and bars were also ordered to size when possible. All mounts were made from Al6061 and the reasons for these selections are listed under the respective design concept selection. The cost of material can be found under “Procurement, Budget and Resources” found below and there are no additional costs to testing. The following sections describe the manufacturability, reliability and economics of each mount.

- *Lasers*

The manufacturing process for the lasers would begin by water jetting the structural bars from a plate of material at the appropriate thickness. The holes drilled into the sides of the bars were done manually but can also be included in the .dxf file for water jetting. Holes are then drilled through the top and bottom mounting surfaces, perpendicular to the cut surface. The tolerance for interior angles of the bars must be high to fit well on the frame of the ATV. However, the dimensions outside this can have a lower tolerance. The crossbars are ordered at the appropriate cross sectional dimensions. Cutting these bars were done in the machine shop but can be automated. These bars needs to be drilled and tapped on the cut surfaces, which was done manually The tolerance of the cuts can also be lower since the structural bars are able to tilt along the mount points. Finally, the mount plates are cut using the water jet and require no further machining. The manufacture process for the full mount took about 2 weeks due to shop traffic but can be decreased dramatically.

Installation of the time took very little time since half the mounting point were taken from previously tapped holes on the ATV. The other half needed to be drilled on the upper frame.

- *Encoders*

The encoder mounts were also made primarily using the water jet. The different sized plates required two .dxf files and different locations for the various holes. The tolerance for these

mounts must be higher to properly fit the encoders. The bends and welds were done manually in the machine shop. The bars were also ordered with the appropriate diameter and needed to be cut, drilled and tapped. This was all done in the machine shop but, similar to the laser mounts, can be automated with the proper equipment. Manufacture and assembly took 1 week but can also be greatly decreased.

The holes that needed to be made in the ATV sub frame were drilled. The wheels and axels were removed from the ATV to install the pulleys. This took more time but can be made to fit before ATV assembly to reduce this.

- *Steering Motor*

The steering motor mount was water jet from a plate of appropriate thickness. The holes perpendicular to the cut surface were manually drilled and tapped but can be automated as well. The tolerance of this part must be high to ensure a proper fitting with the previous year's design.

Manufacture and instillation time was under 1 week. The part was fit to the previous year's mount and screwed in without additional holes or cuts needing to be made.

- *Heat Dissipation*

The snorkels used for dissipating heat from the truck of the ATV were made using a 3D printer. The printing process took 60 hours for each snorkel with additional time for painting. The tolerance for this part does not need to be high and can be printed at a lower resolution, which will also decrease printing time. The snorkels then needed to be sanded to fit the curve of the trunk. This was done manually but can be automated. The appropriate holes were then cut in the trunk and the snorkels as well as the fans were mounted. The snorkels also required a filler material to ensure a waterproof seal.

Manufacture took close to a week and cannot be cut down unless a different printer is used, Instillation also took time considering the filler material needed time to dry and holes needed to be drilled in the trunk.

- *GPS/IMU/Router/Antenna*

The GPS, its components and the IMU were all mounted in the trunk using a plate of aluminum. This plate was water jet using the larger machine in the High-Performance Materials Institute. No further machining was required but holes needed to be drilled in the trunk lid to fit the mount, antenna and router. Filler material was also added in the hole above the trunk to ensure waterproofing.

Manufacture and installation was done in one day and can be shortened by automation.

Risk and Reliability Assessment

There are many risks involved any time a large vehicle is moving around people. This risk is greatly increased when a human is not controlling the vehicle. Any small error in code, wiring error, sensor malfunction, or miscalculation can cause the vehicle to behave erratically and harm people or the surrounding environment.

To reduce these risks to humans or the environment, many safety protocols will be implemented into the computer code and mechanical system. If any sensory information is lost the code will automatically release the throttle, straighten the steering, and apply the brake. This same protocol will execute if there are any obstacles sensed in the path of the ATV or if it is oriented at an angle too extreme to correct its path without running off of the road. This protocol will also be implemented if there is any loss of connection between any of the three computers. All of the previous safety protocols will be the primary method of accident prevention. If any of these fail there must be a physical safety protocol that can be activated. The physical safety protocol will be a kill button activated by an operator watching the ATV. If the ATV starts to do anything that could potentially harm humans or the environment that is not protected against by the primary safety protocol, the emergency cutoff switch will be activated by the operator viewing the test. When the cutoff switch is pressed, it will activate a RF relay that activates the same cutoff switch circuit that is already installed on the ATV. If any communication is lost between the RF relay and the button, the cutoff will automatically activate.

One of the requirements of this project was that a human should also be able to operate the ATV when it is not in autonomous mode. Last year all of the actuators were installed such that a human could still drive the vehicle. All of the sensors that will be mounted this year will also not interfere with the human operation of the vehicle. Since there is not much change from a human driving a non-modified ATV compared to the modified one, all of the normal safety precautions associated with driving an ATV will be implemented by the human operator.

Environmental Safety

This project will not pose any major harm to the environment. No large scale chemical or mechanical processes occur that can damage local inhabitants, surroundings or wildlife. However, the vehicle involved is large and heavy enough to damage trees or humans if traveling at a high enough speed. The ATV is also gas powered, so this may pose a threat if the tank were to rupture. The safety protocol for this is discussed under Risk and Reliability Assessment. These precautions will ensure the safety of the people and environment around the ATV.

The mounts were designed to be as ergonomic as possible with respect to the driver. No sensors will be in direct contact or interference with the driver of the ATV.

Communications

Communicating between team members, advisors, sponsors, and the general public about a project this large can be a difficult task. To have maximum clarity in communication between team members, group texting was set up on day one as well as the sharing of emails. Also due to the large number of files that everyone needed to share on a daily basis, a Dropbox account was set up so all team members could access all files at any time from any computer connected to the internet. These steps helped immensely with team organization and communication. To ensure the group could communicate together as a whole, weekly team meetings were set up so the team could express concerns, share and debate ideas, and prepare for presentations.

Communication with the team sponsor, Dr. Chuy, was fairly straightforward because the lab in which the team worked on the ATV was the same lab in which Dr. Chuy works. This resulted in very regular meetings with Dr. Chuy.

In order to communicate to the public, all team members sharpened their technical presentation skills. This was imperative to our success in explaining our project effectively. Also an easy to follow poster was created for the public to get a good idea of the project quickly and efficiently.

Conclusion

The scope of this project is very large. Many considerations have been taken in the final design of each component and the proper analysis has been applied to prove the functionality of each design. Each design has been selected, analyzed, manufactured, installed, wired, and most of them have been tested. All of the sensors, except for the encoders, have drivers written to obtain data. The utilization of ROS for sensor communication and communication between on board computers has been developed but was not tested fully due to time constraints. The first versions of both autonomous algorithms were also developed, but the testing of these algorithms fell victim to the same time constraint.

Mechanically, the ATV is very near ready. The goal of the project was to provide a proof of concept that the ATV can function autonomously. The fact that we have obtained good sensory data, are able to move the actuators proves that reaching the goal of the project was a partial success. More time is needed to develop and test code. Continuation of this project for next year with a team of computer and electrical engineers would be advantageous, or the project can now be handed over to the CISCOR researchers, with their superior coding skills, to finish developing and testing the communication.

Recommendations for Future Work

There is a small list of items that need to be finished and a small list of recommendations for next year.

To be finished:

- Wiring of encoders for power and data
- OS set up of single board computer
- Purchase and install RF cutoff switch for increased safety
- Create ROS packages for IMU, GPS, and encoders

Recommendations:

- Installation of skid plate to protect encoders
- Replace both lasers with one, vertically scanning laser
- Install stereoscopic camera
- Revise autonomous algorithms

Procurement/Budget/Resources

For this project, CISCOR has already supplied the sensors, ATV, workspace, and a budget of 1500.00 USD. This budget is set aside mainly for wiring, connectors and building materials for sensor mounts. Some of the materials that will be used will be acquired from scrap pieces from the FSU/COE machine shop. This is done to reduce the cost of buying large sheets of new material for small parts that need to be made when there are plenty of sufficiently sized pieces of material available for free.

A large amount of the raw materials will be purchased from McMaster-Carr which is a widely used source of parts that FSU/COE uses. This decision was made due to the fact that parts from McMaster-Carr usually arrive within 2 days of the order. A simple breakdown of costs are as follows:

- Budget: 1500.00 USD
- Raw materials: 617.99
- Fasteners: 62.22
- Misc. Electrical: 146.69
- 3D printing: 300.00
- Total: 1126.90
- Remaining: 373.10

The FAMU/FSU College of Engineering has many resources available for the team to use. At the main workspace in the CISCOR lab there are all of the necessary tools needed to disassemble and reassemble the necessary parts of the ATV. The CISCOR lab also supplies all of the electrical equipment necessary for assembling and testing the electrical systems including DMM's, computers, oscilloscopes, soldering irons, wires, and connectors. CISCOR and the College of Engineering also supply all of the manufacturing tools needed to create all of the parts needed for mounting the sensors. In the lab there is a small machine shop with a 2D laser cutter used for rapid prototyping using ABS plastic and a drill press along with other necessary manufacturing tools. Knowing that the machine shop will be very busy during the next semester, most of the parts we were designed in such a way that they can be cut out in 2D on a water jet and assembled later. This was done because a student on the team is authorized to operate the water jet and does not need to submit work orders and wait a long time for parts to be made. This will cut down drastically on manufacturing time and brings simplicity to the designs. In any of the parts that need excess machining, the machine shop at the College of Engineering also has a CNC, lathe, and an end mill.

Gantt Chart

Team 10 Autonomous ATV (GOLIATH)

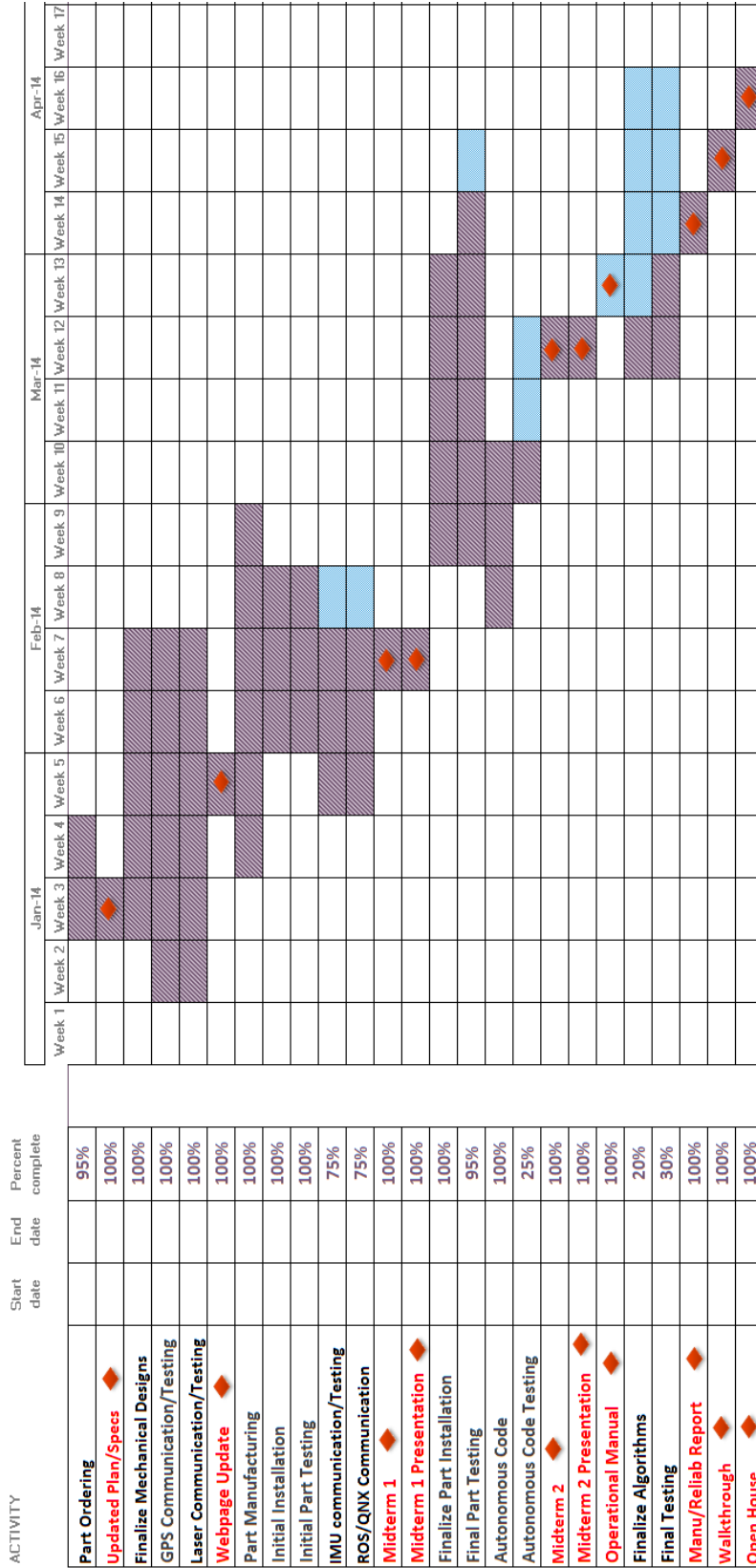

References

- 1) <http://sicktoolbox.sourceforge.net/docs/sick-lms-technical-description.pdf>
- 2) <http://www.novatel.com/assets/Documents/Papers/ProPakG2plus.pdf>
- 3) http://saba.kntu.ac.ir/eecd/ecourses/instrumentation/projects/reports/Poly%20Gyroscope/Producers/Crossbow/IMU/6020-0019-01_B_IMU300CC.pdf
- 4) <http://www.ctiautomation.net/PDF/Accu-Coder/Accu-Coder-725-Shaft-Encoders.pdf>
- 5) http://www.maxonmotorusa.com/medias/sys_master/8807014760478/13_106_EN.pdf
- 6) http://www.rvok.net/tmp/Reilly.AI.for.Game.Developers/ch06_sect1_005.html
- 7) http://www.rvok.net/tmp/Reilly.AI.for.Game.Developers/ch06_sect1_001.html
- 8) <http://www.padaengineering.com/superplate-heat-sinks.html>
- 9) Sengal, Yunus. Fundamentals of Thermal-Fluid Science. 4th ed : McGraww-Hill, 2012.

Appendix

A-1

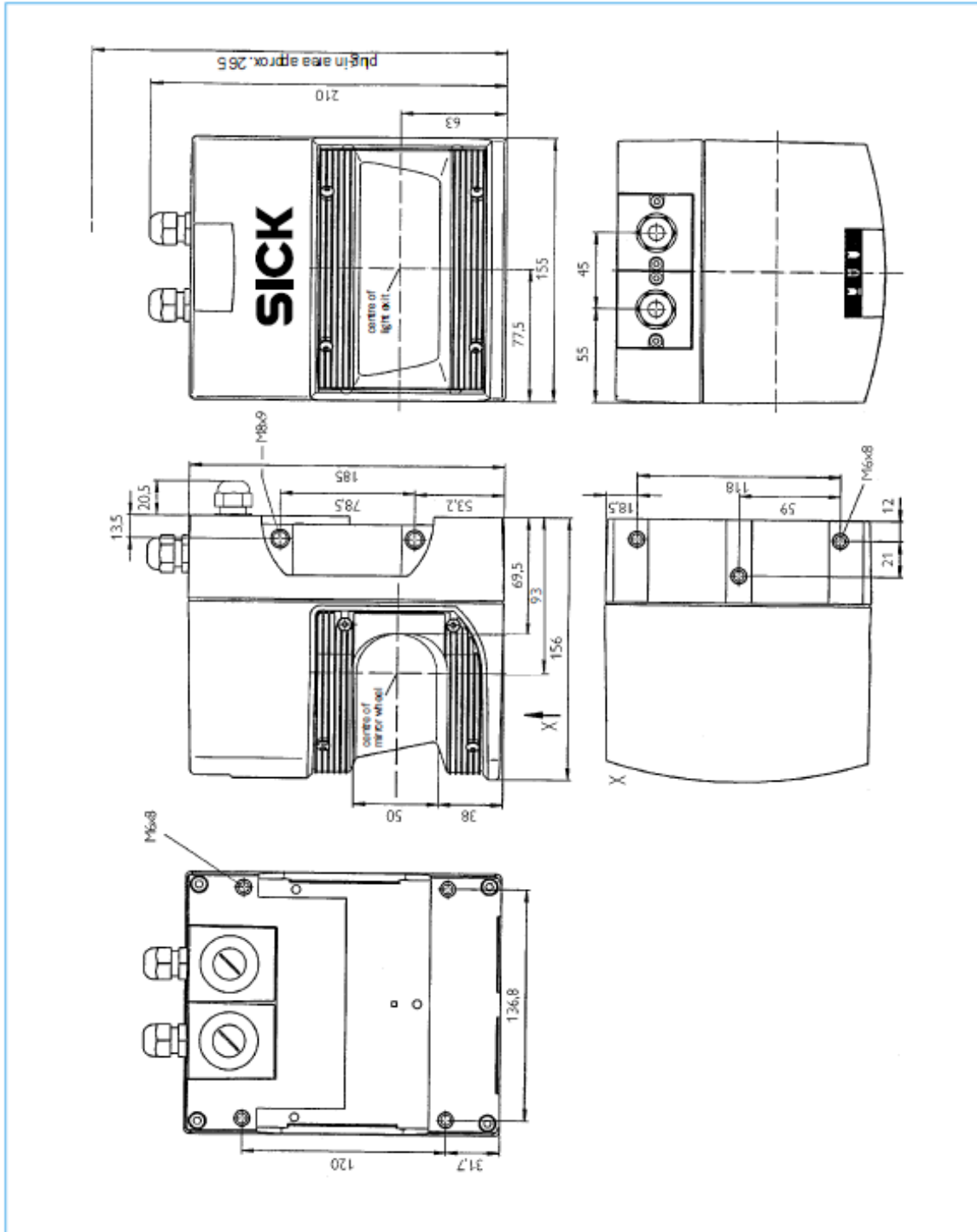

A-2

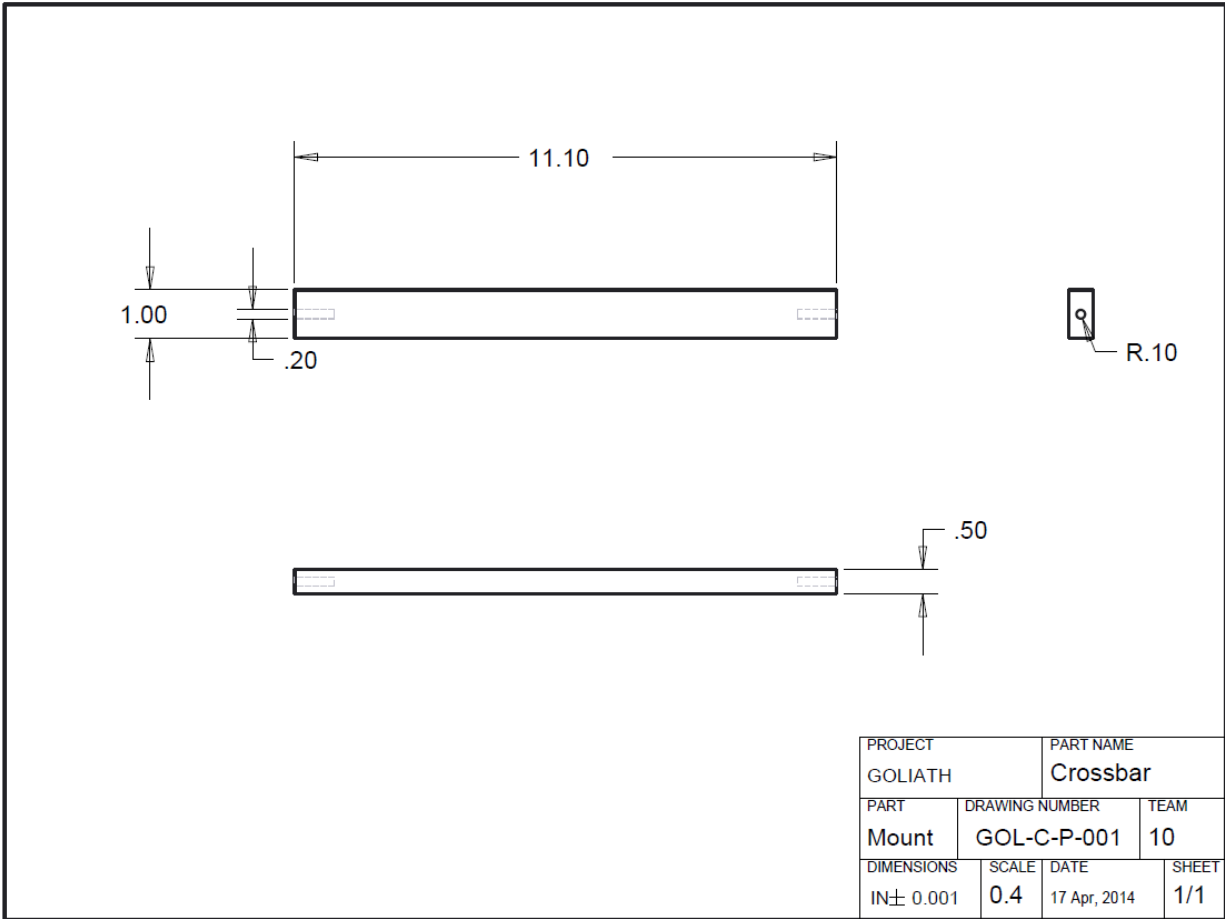

PROJECT		PART NAME	
GOLIATH		Crossbar	
PART	DRAWING NUMBER	TEAM	
Mount	GOL-C-P-001	10	
DIMENSIONS	SCALE	DATE	SHEET
IN ± 0.001	0.4	17 Apr, 2014	1/1

A-3

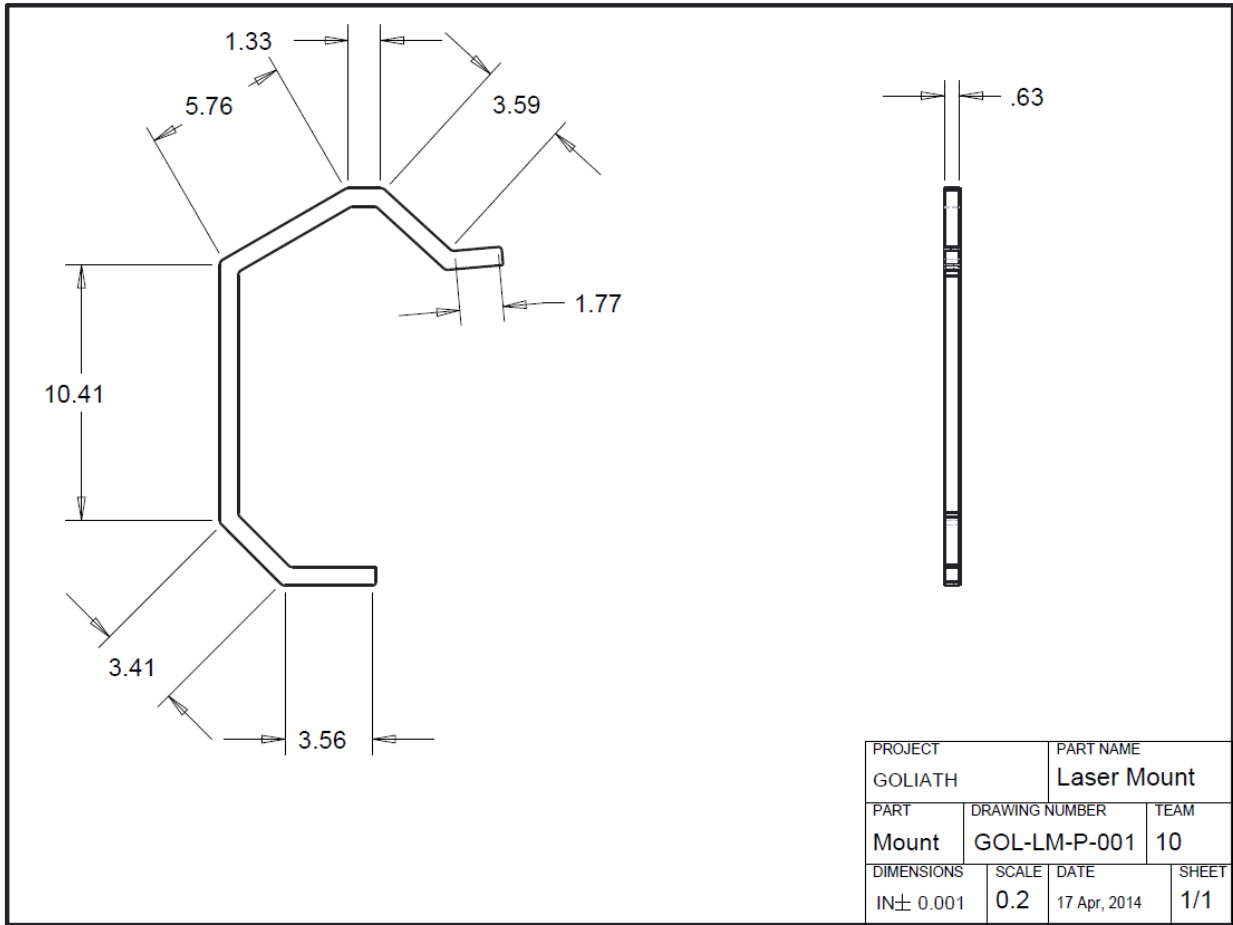

A-4

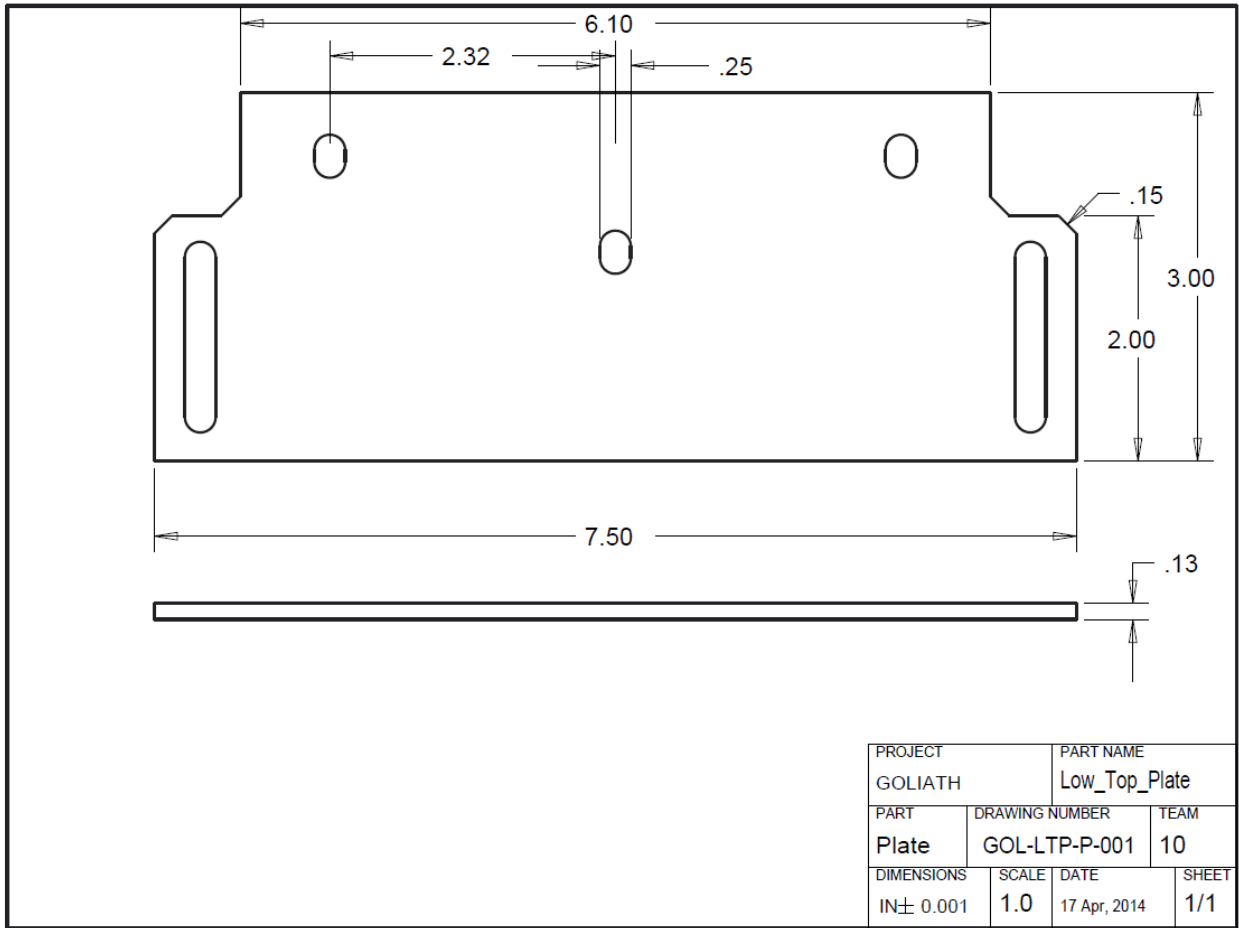

A-5

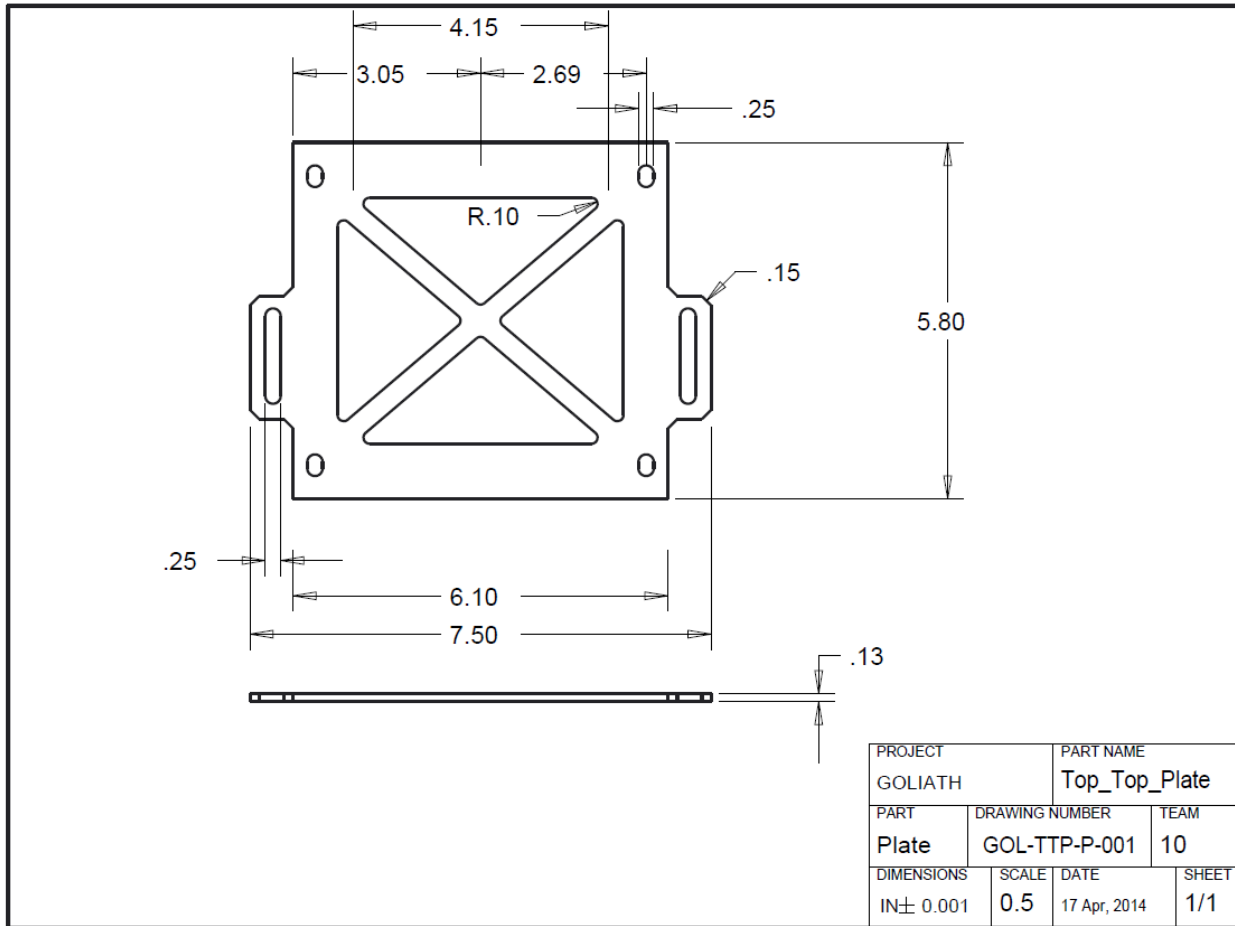

Model 725 Flange Mount (F)

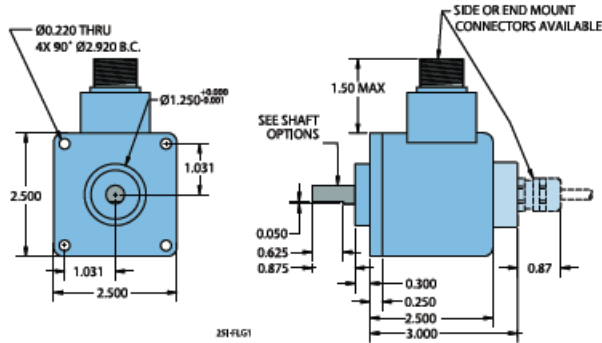

Model 725 Specifications

Electrical	
Input Voltage.....	4.75 to 28 VDC max for temperatures up to 70° C 4.75 to 24 VDC for temperatures between 70° C to 100° C
Input Current.....	100 mA max with no output load
Input Ripple.....	100 mV peak-to-peak at 0 to 100 kHz
Output Format.....	Incremental- Two square waves in quadrature with channel A leading B for clockwise shaft rotation, as viewed from the encoder mounting face. See <i>Waveform Diagrams</i> below.
Output Types.....	Open Collector- 100 mA max per channel Pull-Up- 100 mA max per channel Push-Pull- 20 mA max per channel Line Driver- 20 mA max per channel (Meets RS 422 at 5 VDC supply)
Index.....	Occurs once per revolution. The index for units >3000 CPR is 90° gated to Outputs A and B. See <i>Waveform Diagrams</i> below.
Max Frequency.....	Up to 1 MHz
Noise Immunity.....	Tested to BS EN61000-4-2; IEC801-3; BS EN61000-4; DENV 50141; DENV 50204; BS EN55022 (with European compliance option); BS EN61000-6-2; BS EN50081-2
Symmetry.....	1 to 6000 CPR: 180° (±18°) electrical at 100 kHz output 6001 to 20,480 CPR: 180° (±36°) electrical
Quad Phasing.....	1 to 6000 CPR: 90° (±22.5°) electrical at 100 kHz output 6001 to 20,480 CPR: 90° (±36°) electrical
Min Edge Sep.....	1 to 6000 CPR: 67.5° electrical at 100 kHz output 6001 to 20,480 CPR: 54° electrical >20,480 CPR: 50° electrical
Rise Time.....	Less than 1 microsecond
Accuracy.....	Instrument and Quadrature Error: For 200 to 1999 CPR, 0.017° mechanical (1.0 arc minutes) from one cycle to any other cycle. For 2000 to 3000 CPR, 0.01° mechanical (0.6 arc minutes) from one cycle to any other cycle. Interpolation error (units > 3000 CPR only) within 0.005° mechanical. (Total Optical Encoder Error = Instrument + Quadrature + Interpolation)
Mechanical	
Max Shaft Speed.....	8000 RPM. Higher shaft speeds may be achievable, contact Customer Service.
Shaft Size.....	0.375" (standard), 0.250", 0.3125", 6 mm, 8 mm, 10 mm
Shaft Material.....	303 stainless steel
Shaft Rotation.....	Bi-directional
Radial Shaft Load.....	80 lb max (standard housing) 80 lb max (industrial housing)
Axial Shaft Load.....	80 lb max (standard housing) 80 lb max (industrial housing)
Starting Torque.....	1.0 oz-in typical with IP64 seal or no seal 3.0 oz-in typical with shaft seals
Moment of Inertia.....	5.2 x 10 ⁻⁴ oz-in-sec ²
Max Acceleration.....	1 x 10 ⁵ rad/sec ²
Electrical Conn.....	6-, 7-, or 10-pin MS Style, 5- or 8-pin M12 (12 mm), 9-pin D-subminiature, or gland with 24 inches of cable (foil and braid shield, 24 AWG conductors)
Housing.....	Black non-corrosive finish
Bearings.....	Precision ABEC ball bearings
Mounting.....	Flange, servo, or 5PY
Weight.....	20 oz typical
Environmental	
Operating Temp.....	0° to 70° C for standard models 0° to 100° C for high temperature option (0° to 85° C for certain resolutions, see CPR Options.) -40° to 70° C
Storage Temp.....	-25° to +85° C
Humidity.....	95% RH non-condensing
Vibration.....	725N: 10 g @ 58 to 500 Hz 725I: 20 g @ 58 to 500 Hz
Shock.....	725N: 50 g @ 11 ms duration 725I: 75 g @ 11 ms duration
Sealing.....	IP50 standard, IP64, IP66 and IP67 optional

B-2

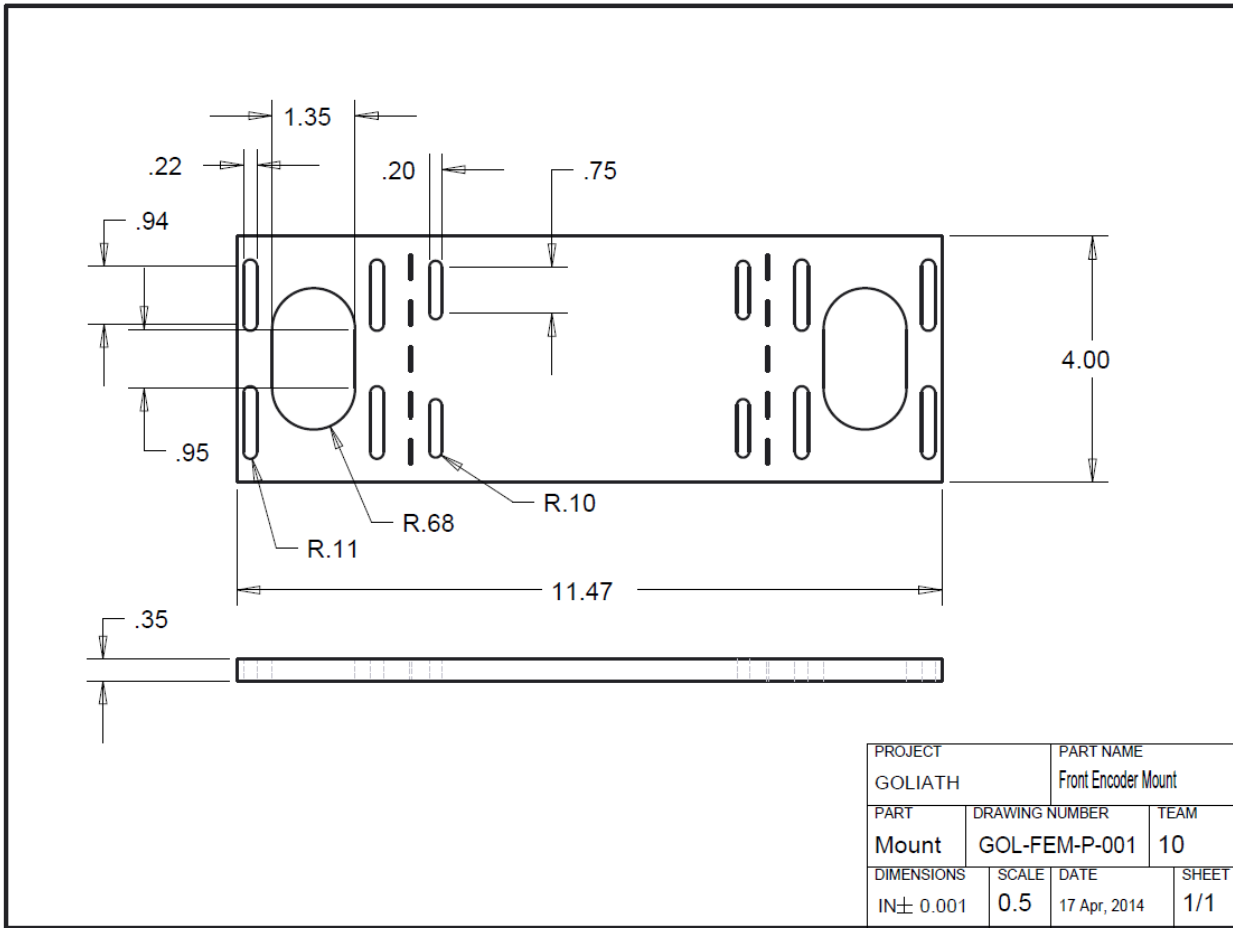

B-3

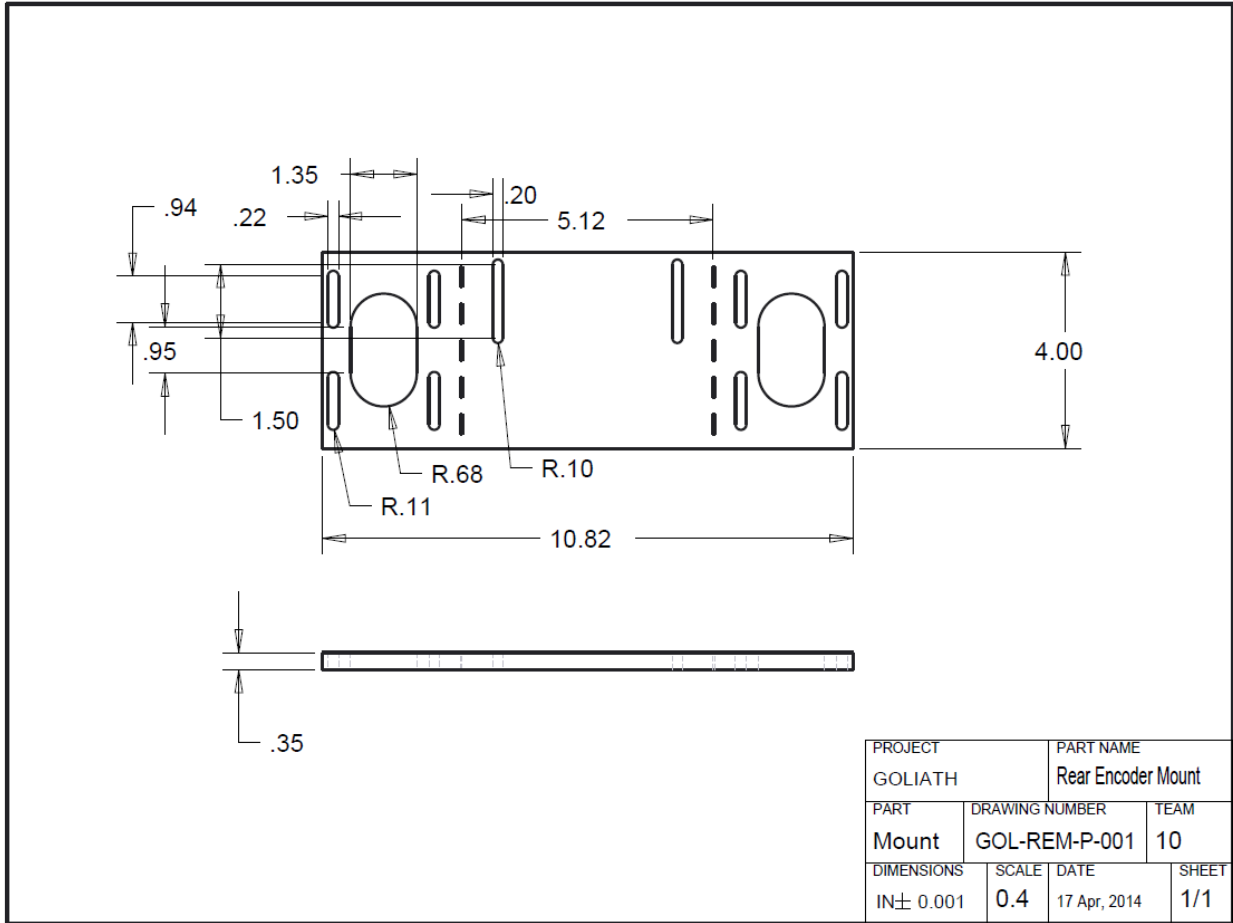

B-4

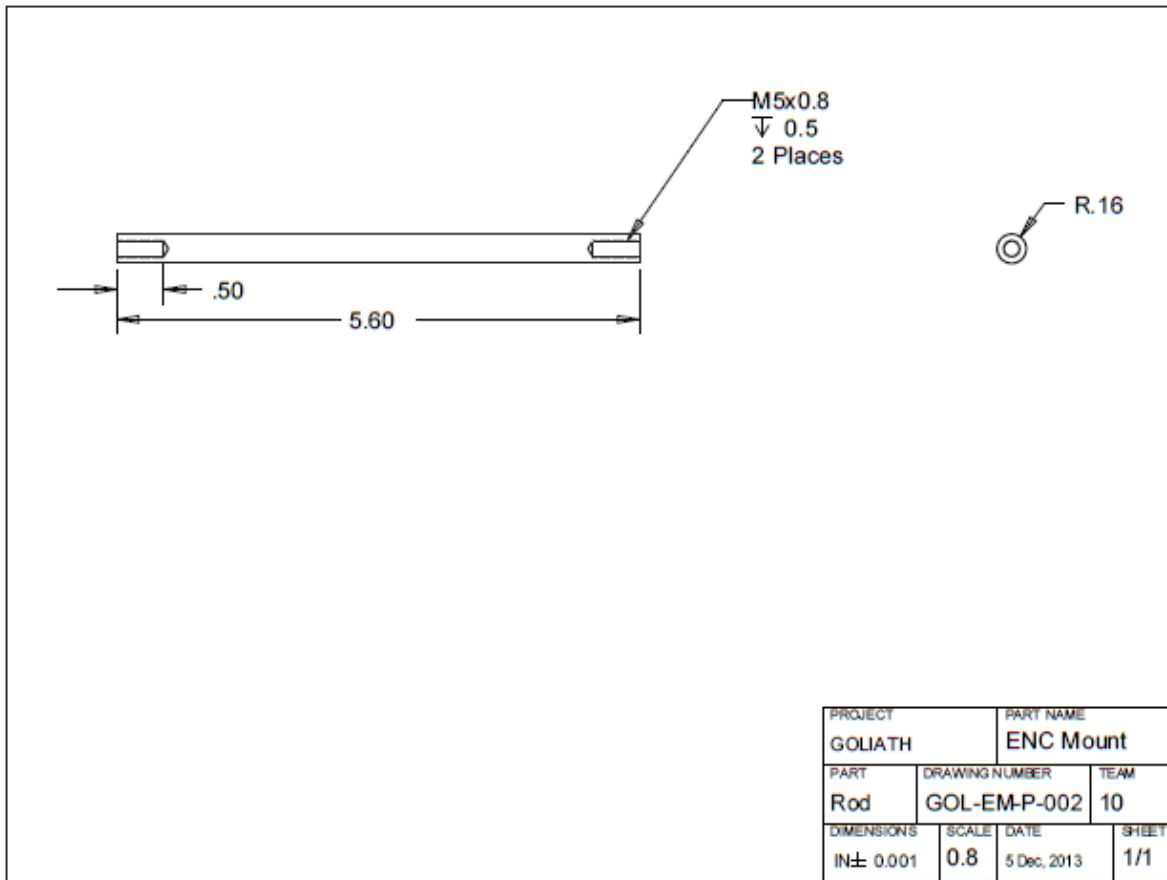

PROJECT		PART NAME	
GOLIATH		ENC Mount	
PART	DRAWING NUMBER	TEAM	
Rod	GOL-EM-P-002	10	
DIMENSIONS	SCALE	DATE	SHEET
IN± 0.001	0.8	5 Dec, 2013	1/1

C-1

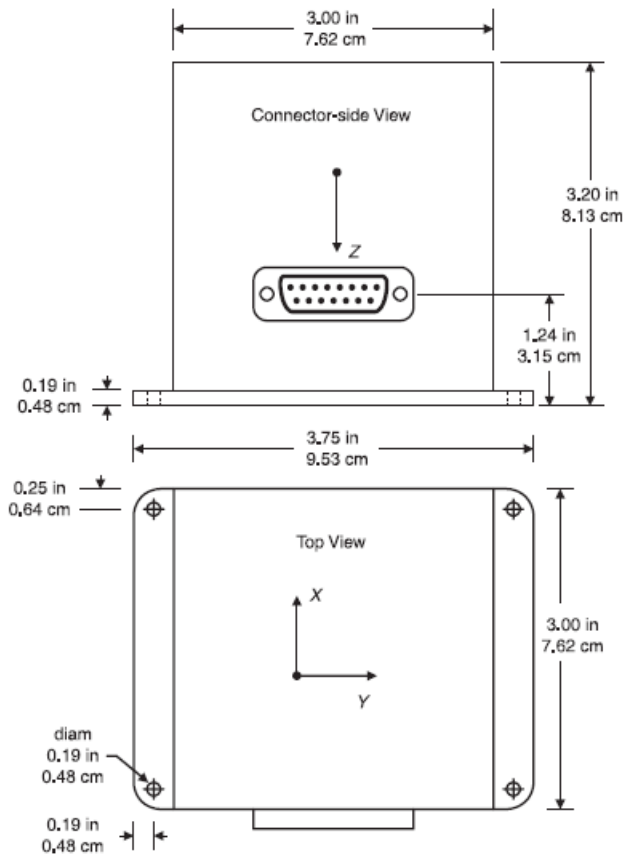

Specifications		IMU300CC-100
Performance		
Update Rate (Hz)		> 100
Start-up Time Valid Data (sec)		< 1
Angular Rate		
Range: Roll, Pitch, Yaw (°/sec)		± 100
Bias: Roll, Pitch, Yaw (°/sec)		< ± 2.0
Scale Factor Accuracy (%)		< 1
Non-Linearity (% FS)		< 0.3
Resolution (°/sec)		< 0.025
Bandwidth (Hz)		> 25
Random Walk (°/hr ^{1/2})		< 2.25
Acceleration		
Range: X/Y/Z (g)		± 2
Bias: X/Y/Z (mg)		< ± 30
Scale Factor Accuracy (%)		< 1
Non-Linearity (% FS)		< 1
Resolution (mg)		< 1.0
Bandwidth (Hz)		> 75
Random Walk (m/s/hr ^{1/2})		< 0.15
Environment		
Operating Temperature (°C)		-40 to +85
Non-Operating Temperature (°C)		-55 to +85
Non-Operating Vibration (g rms)		6
Non-Operating Shock (g)		1000
Electrical		
Input Voltage (VDC)		9 to 30
Input Current (A)		< 250
Power Consumption (W)		< 3
Digital Output Format		RS-232
Analog ¹ Range (VDC)		± 4.096
		0 to 5.0
Physical		
Size	(in)	3.0 x 3.75 x 3.20
	(cm)	7.62 x 9.53 x 8.13
Weight	(lbs)	< 1.3
	(kg)	< 0.59
Connector		15 pin sub-miniature "D"

ProPak-G2plus

Performance¹

Position Accuracy	
Single Point L1	1.8 m CEP
Single Point L1/L2	1.5 m CEP
WAAS L1	1.2 m CEP
WAAS L1/L2	0.8 m CEP
DGPS (L1, C/A)	0.45 m CEP
RT-20 ²	< 20 cm CEP
RT-2	1 cm + 1 ppm

Measurement Precision

L1 C/A Code	6 cm RMS
L2 P(Y) Code	25 cm RMS (AS on)
L1 Carrier Phase	0.75 mm RMS (differential channel)
L2 Carrier Phase	2 mm RMS (differential channel)

Data Rate

Measurements	20 Hz
Position	20 Hz

Time to First Fix

Cold Start ³	50 s
Warm Start ⁴	40 s
Hot Start ⁵	30 s

Signal Reacquisition

L1	0.5 s (typical)
L2	1.0 s (typical)

Time Accuracy⁶	20 ns RMS
----------------------------------	------------------

Velocity Accuracy	0.03 m/s RMS
--------------------------	---------------------

Dynamics

Velocity ⁷	514 m/s
Vibration	4 G (sustained tracking)

Altitude⁷	18,288 m
-----------------------------	-----------------

Physical & Electrical

Size	185 x 154 x 71 mm
-------------	--------------------------

Weight	1.0 kg
---------------	---------------

Power

Input Voltage ⁸	+9 to +18 VDC
Power Consumption	2.5 W (typical)

Antenna LNA Power Output

Output Voltage	+5 VDC
Maximum Current	100 mA

Communication Ports

- 2 RS-232 or RS-422 serial ports capable of 230,400 bps
- 1 RS-232 serial port capable of 230,400 bps
- 1 USB port capable of 5 Mbps

Input/Output Connectors

Power	4-pin LEMO
Antenna Input	TNC female
External Oscillator	BNC female
COM1	DB-9 male
COM2	DB-9 male
AUX (COM3)	DB-9 male
I/O	DB-9 female

Environmental

Temperature	
Operating	-40°C to +75°C
Storage	-45°C to +95°C
Humidity	95% non-condensing
Waterproof	IEC 60529 IPX7
Vibration (operating)	
Random	MIL-STD-202F 214A
Sinusoidal	SAE J1211 4.7
Shock (non-operating)	IEC 68-2-27 Ea

Regulatory	FCC Class B, CE
-------------------	------------------------

D-2

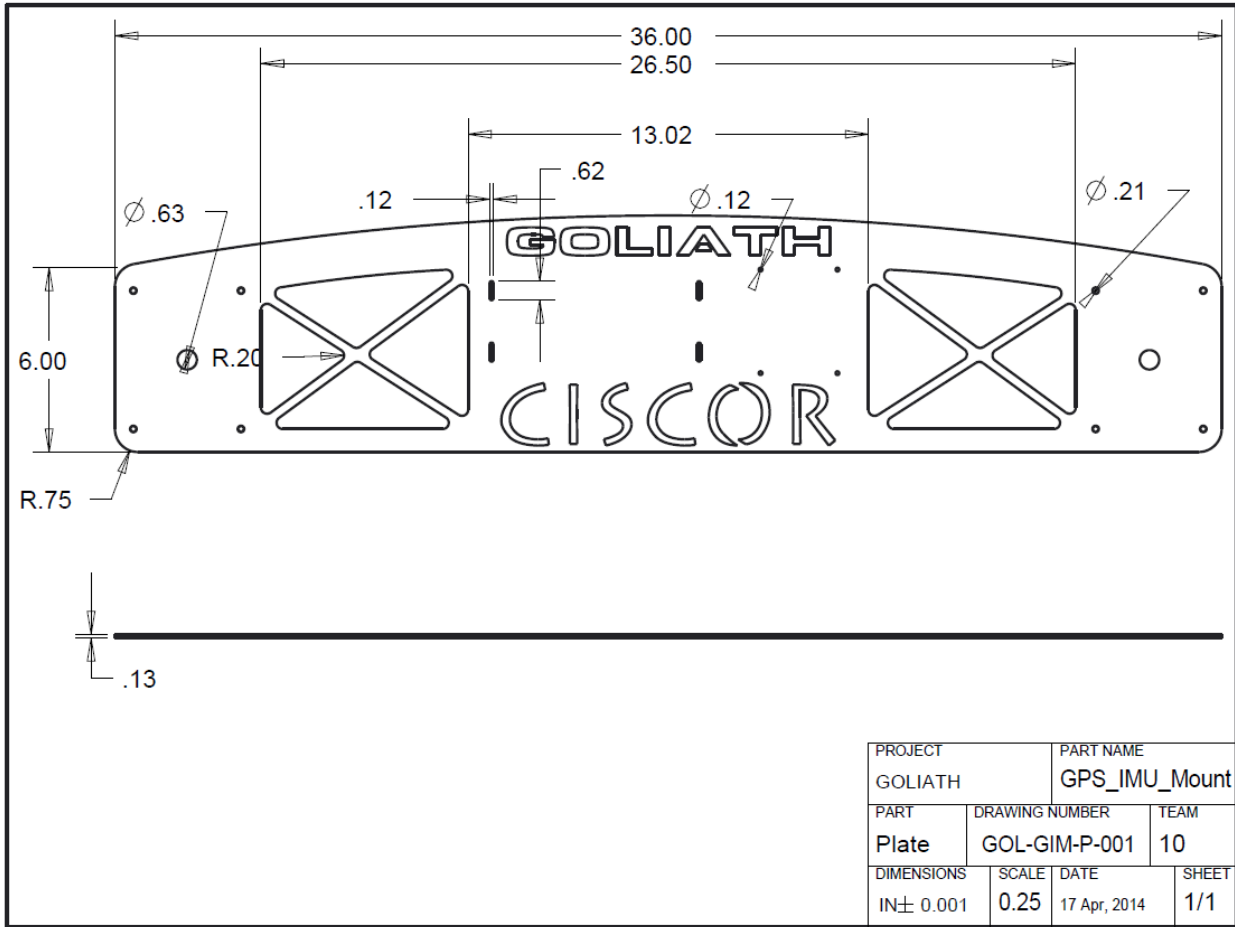

RE 50 Ø50 mm, Graphite Brushes, 200 Watt

maxon DC motor

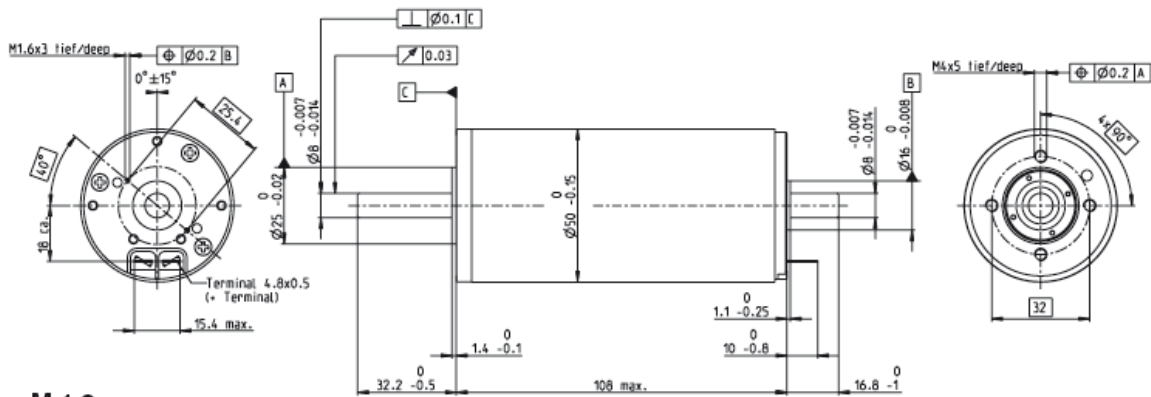

M 1:2

- Stock program
- Standard program
- Special program (on request)

Part Numbers

370354	370355	370356	370357
--------	--------	--------	--------

Motor Data		370354	370355	370356	370357
Values at nominal voltage					
1 Nominal voltage	V	24	36	48	70
2 No load speed	rpm	5950	5680	4900	2760
3 No load current	mA	236	147	88.4	27.4
4 Nominal speed	rpm	5680	5420	4620	2470
5 Nominal torque (max. continuous torque)	mNm	405	418	420	452
6 Nominal current (max. continuous current)	A	10.8	7.07	4.58	1.89
7 Stall torque	mNm	8920	8920	7370	4340
8 Starting current	A	232	148	78.9	17.9
9 Max. efficiency	%	94	94	94	92
Characteristics					
10 Terminal resistance	Ω	0.103	0.244	0.608	3.9
11 Terminal inductance	mH	0.0717	0.177	0.423	2.83
12 Torque constant	mNm/A	38.5	60.4	93.4	242
13 Speed constant	rpm/V	248	158	102	39.5
14 Speed / torque gradient	rpm/mNm	0.668	0.638	0.666	0.638
15 Mechanical time constant	ms	3.75	3.74	3.78	3.74
16 Rotor inertia	gcm ²	536	560	542	560

Specifications	
Thermal data	
17 Thermal resistance housing-ambient	3.8 K/W
18 Thermal resistance winding-housing	1.2 K/W
19 Thermal time constant winding	71.7 s
20 Thermal time constant motor	1370 s
21 Ambient temperature	-30...+100°C
22 Max. permissible winding temperature	+125°C
Mechanical data (preloaded ball bearings)	
23 Max. permissible speed	9500 rpm
24 Axial play at axial load < 11.5 N	0 mm
24 Axial play at axial load > 11.5 N	0.1 mm
25 Radial play	preloaded
26 Max. axial load (dynamic)	30 N
27 Max. force for press fits (static)	150 N
27 Max. force for press fits (static)	(static, shaft supported)
27 Max. force for press fits (static)	6000 N
28 Max. radial loading, 15 mm from flange	110 N
Other specifications	
29 Number of pole pairs	1
30 Number of commutator segments	15
31 Weight of motor	1100 g

Values listed in the table are nominal.
Explanation of the figures on page 71.
Industrial version with radial shaft seal ring (resulting in increased no-load current)

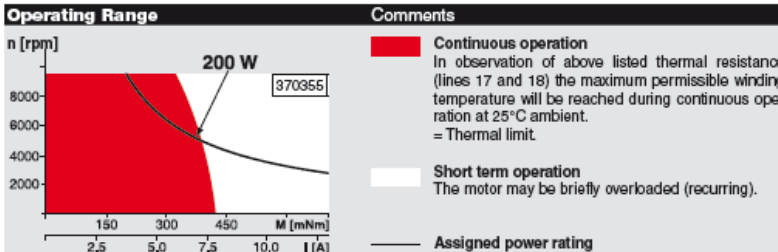

maxon Modular System		Overview on page 20 - 25	
1 Planetary Gearhead Ø52 mm 4 - 30 Nm Page 273		Encoder HEDS 5540 500 CPT, 3 channels Page 306	Encoder HEDL 5540 500 CPT, 3 channels Page 308
15 Planetary Gearhead Ø62 mm 8 - 50 Nm Page 275		Industrial Version IP54 Encoder HEDL 9140 Page 311 Brake AB 44 Page 352 End cap Page 353	
Recommended Electronics: ESCON 50/5 Page 321 ESCON Module 50/5 321 ESCON 70/10 321 EPOS2 50/5 331 EPOS2 70/10 331 EPOS3 70/10 EtherCAT 337 Notes 22			

Planetary Gearhead GP 62 A $\varnothing 62$ mm, 8–50 Nm

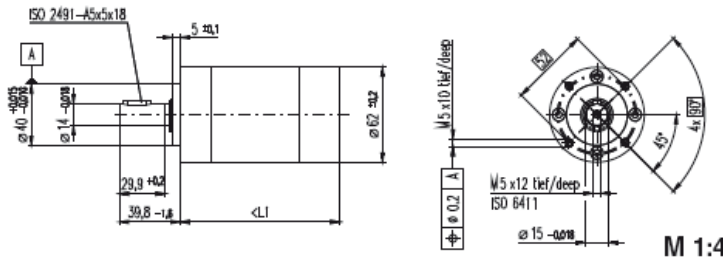

Technical Data	
Planetary Gearhead	straight teeth
Output shaft	steel
Bearing at output	ball bearing
Radial play, 7 mm from flange	max. 0.08 mm
Axial play	max. 1 mm
Max. permissible axial load	120 N
Max. permissible force for press fits	1000 N
Sense of rotation, drive to output	=
Recommended input speed	< 3000 rpm
Recommended temperature range	-30...+140°C
Number of stages	1 2 3
Max. radial load, 24 mm from flange	240 N 360 N 570 N

maxon gear

- Stock program
- Standard program
- Special program (on request)

Part Numbers

	110499	110501	110502	110503	110504	110505	110506	110507	110508
Gearhead Data									
1 Reduction	5.2:1	19:1	27:1	35:1	71:1	100:1	139:1	181:1	236:1
2 Reduction absolute	57/11	358/187	3249/121	1539/44	21623/3179	204807/2027	186125/1331	87723/404	41553/276
3 Max. motor shaft diameter	mm 8	8	8	8	8	8	8	8	8
4 Number of stages	1	2	2	2	3	3	3	3	3
5 Max. continuous torque	Nm 8	25	25	25	50	50	50	50	50
6 Intermittently permissible torque at gear output	Nm 12	37	37	37	75	75	75	75	75
7 Max. efficiency	% 80	75	75	75	70	70	70	70	70
8 Weight	g 950	1250	1250	1250	1540	1540	1540	1540	1540
9 Average backlash no load	° 1.0	1.5	1.5	1.5	2.0	2.0	2.0	2.0	2.0
10 Mass inertia	gcm ² 109	100	105	89	104	105	102	88	89
11 Gearhead length L1	mm 72.5	88.3	88.3	88.3	104.2	104.2	104.2	104.2	104.2



maxon Modular System												
+ Motor	Page	+ Sensor	Page	Brake	Page	Overall length [mm] = Motor length + gearhead length + (sensor/brake) + assembly parts						
RE 50, 200 W	106				180.6	196.4	196.4	196.4	212.3	212.3	212.3	212.3
RE 50, 200 W	106	HEDS 5540	306		201.3	217.1	217.1	217.1	233.0	233.0	233.0	233.0
RE 50, 200 W	106	HEDL 5540	308		201.3	217.1	217.1	217.1	233.0	233.0	233.0	233.0
RE 50, 200 W	106	HEDL 9140	311		243.0	258.8	258.8	258.8	274.7	274.7	274.7	274.7
RE 50, 200 W	106			AB 44 352	243.0	258.8	258.8	258.8	274.7	274.7	274.7	274.7
RE 50, 200 W	106	HEDL 9140	311	AB 44 352	256.0	271.8	271.8	271.8	287.7	287.7	287.7	287.7
EC 45, 250 W	183				216.6	232.4	232.4	232.4	248.3	248.3	248.3	248.3
EC 45, 250 W	183	HEDL 9140	310		232.2	248.0	248.0	248.0	263.9	263.9	263.9	263.9
EC 45, 250 W	183	Res 26	316		216.6	232.4	232.4	232.4	248.3	248.3	248.3	248.3
EC 45, 250 W	183			AB 28 349	224.0	239.8	239.8	239.8	255.7	255.7	255.7	255.7
EC 45, 250 W	183	HEDL 9140	310	AB 28 349	241.0	256.8	256.8	256.8	272.7	272.7	272.7	272.7

E-3

